

Sioux Lookout Hydro Inc.
P.O. Box 908, 25 Fifth Ave.
Sioux Lookout, ON P8T 1B3
Phone: (807)737-3800
Fax: (807)737-2832
Email: slhydro@tbaytel.net

October 31, 2007

Kirsten Walli, Board Secretary
Ontario Energy Board
P.O. Box 2319
27th Floor
2300 Yonge Street
TORONTO, ON M4P 1E4

**RE: Sioux Lookout Hydro Incorporated
2008 Rate Application – Amended
Board File No. EB-2007-0785**

Dear Ms. Walli:

Please find attached Sioux Lookout Hydro Inc.'s amended 2008 rate application. The following amendments are included:

1. Changes made to the wording and corresponding Schedule numbers in Exhibits 1, 2, 3, 4, 5, 8 and 9 to match the body of the report.
2. Corrections made to the retail transmission rates.

If there are any questions or concerns, please do not hesitate to contact me.

Yours truly,

Deanne Kulchyski
Financial & Regulatory Affairs Officer

Encl/

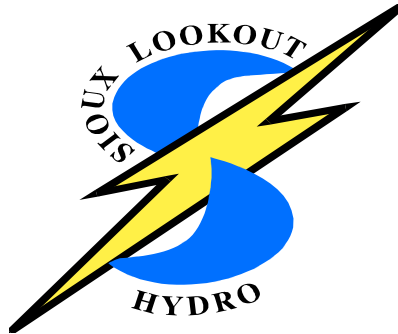

2008 EDR Application

EB-2007-0785

SUBMITTED OCTOBER 2, 2007

(Revised October 31, 2007)

SIOUX LOOKOUT HYDRO INCORPORATED
25 FIFTH AVE., P.O. BOX 908
SIOUX LOOKOUT, ON P8T 1B3

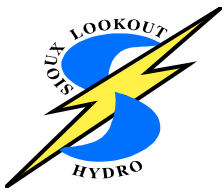

SIOUX LOOKOUT HYDRO INC.

INDEX

<u>Ex.</u>	<u>Tab</u>	<u>Schedule</u>	<u>Contents of Schedule</u>
<u>1 - Administrative Documents</u>			
	1		<u>Application Summary</u>
		1	Index
		2	Application
		3	Summary of Application
		4	Current Rates
		5	Proposed Rates
		6	Summary of Bill Impact
		7	List of Issues
		8	List of Specific Approvals Requested
		9	Revenue Deficiency/Sufficiency
		10	Causes of the Deficiency/Sufficiency
		11	Board Findings and Directions from 2007 EDR
		12	Board Findings and Directions from 2006 EDR
		13	Status of Board Directives
		14	Uniform System Of Accounts and Accounting Orders
	2		<u>Company Overview</u>
		1	Utility Description
		1	Contact Information
		1	List of Neighboring Utilities
		1	Explanation of Any Host or Embedded Utilities
		2	LDC's Distribution License
		3	Map of LDC's Distribution System
		4	Utility Organizational Chart
		5	Corporate Entities Relationships Chart
		6	Planned Changes in Corporate or Operational Structure



SIOUX LOOKOUT HYDRO INC.

7	Conditions of Service/Service Charges
8	Changes in Conditions of Service
9	List of Witnesses and their Curriculum Vitae
10	Budget Directives (Capital and Operating)
11	Changes in Methodology
3	<u>Finance</u>
1	Financial Statement (2006)
2	Pro Forma Statements (2007 and 2008)
3	Reconciliation between Financial Statements and Financial Results Filed
4	Proposed Accounting Treatment for long lived assets

**SIOUX LOOKOUT HYDRO INC.**

<u>Ex.</u>	<u>Tab</u>	<u>Schedule</u>	<u>Contents of Schedule</u>
<u>2 – Rate Base</u>			
	1		<u>Overview</u>
		1	Rate Base Overview
		2	Rate Base Summary Table
		3	Variance Analysis on Rate Base Table
	2		<u>Gross Assets – Property, Plant and Equipment</u>
			<u>Accumulated Depreciation</u>
		1	Continuity Statements
		2	Gross Assets Table
		3	Materiality Analysis on Gross Assets
		4	Accumulated Depreciation Table
		5	Materiality Analysis on Accumulated Depreciation
	3		<u>Capital Budget</u>
		1	Capital Budget by Project
		2	Description of Capital Plan including Materiality Analysis on Capital Additions
		3	System Expansions
		4	Capitalization Policy
	4		<u>Allowance for Working Capital</u>
		1	Working Capital Allowance calculations by account

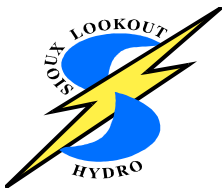

SIOUX LOOKOUT HYDRO INC.

<u>Ex.</u>	<u>Tab</u>	<u>Schedule</u>	<u>Contents of Schedule</u>
<u>3 - Distribution Revenue</u>			
	1	1	Overview of Distribution Revenue
		2	Summary of Distribution Revenue Table
		3	Variance Analysis on Distribution Revenue
	2		Throughput Revenue
		1	Weather Normalized Forecasting Methodology
		2	Population Change in Northern Ontario - 2006 Census Research Study
		3	Normalized Volume Forecast Table
		4	Customer Count Forecast Table
		5	Historical Average Consumption
	3		Other Revenue
		1	Other Distribution Revenue
		2	Materiality Analysis on Other Distribution Revenue
		3	Rate of Return on Other Distribution Revenue
		4	Distribution Revenue Data
	4		Revenue Sharing
		1	Description of Revenue Sharing

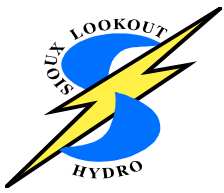
**SIOUX LOOKOUT HYDRO INC.**

<u>Ex.</u>	<u>Tab</u>	<u>Schedule</u>	<u>Contents of Schedule</u>
<u>4 - Operating Costs</u>			
	1		Overview
		1	Overview of Operating Costs
		2	Summary of Operating Costs Table
	2		OM&A Costs
		1	OM&A Costs Table
		2	Variance Analysis on OM&A Costs Table
		3	Materiality Analysis on OM&A Costs
		4	Shared Services
		5	Corporate Cost Allocation
		6	Purchase of Services
		7	Employee Description
		8	Depreciation, Amortization and Depletion
		9	Loss Adjustment Factor Calculation
		10	Materiality Analysis on Distribution Losses
		11	Retail Transmission Adjustment
	3		Income Tax, Large Corporation Tax
		1	Tax Calculations
		2	Capital Cost Allowance (CCA)



SIOUX LOOKOUT HYDRO INC.

<u>Ex.</u>	<u>Tab</u>	<u>Schedule</u>	<u>Contents of Schedule</u>
<u>5 - Deferral And Variance Accounts</u>			
	1	1	Description of Deferral and variance accounts
		2	Calculation of Balances by Account
		3	2008 Rate Rider
		4	Method of Recovery

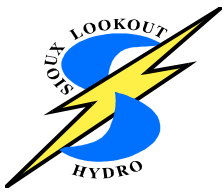

SIOUX LOOKOUT HYDRO INC.

Ex. Tab Schedule Contents of Schedule

6 – Cost of Capital and Rate of Return

1	1	Overview
	2	Cost of Debt
	3	Return on Equity



SIOUX LOOKOUT HYDRO INC.

Ex. Tab Schedule Contents of Schedule

7 - Calculation of Revenue Deficiency or Surplus

1	1	Overview of Calculation of Revenue Deficiency or Surplus
	2	Determination of Net Utility Income



SIOUX LOOKOUT HYDRO INC.

<u>Ex.</u>	<u>Tab</u>	<u>Schedule</u>	<u>Contents of Schedule</u>
<u>8 – Cost Allocation</u>			
	1	1	Cost Allocation Overview
		2	Summary of Results and Proposed Changes



SIOUX LOOKOUT HYDRO INC.

<u>Ex.</u>	<u>Tab</u>	<u>Schedule</u>	<u>Contents of Schedule</u>
<u>9 - Rate Design</u>			
	1	1	Rate Design Overview
		2	Rate Mitigation
		3	Existing Rate Classes
		4	Existing Rate Schedule
		5	Proposed Rate Classes if different than existing
		6	Proposed Rate Schedule
		7	Determination of Service Revenue Requirement
		8	Reconciliation of Rate Class Revenue to total Revenue Requirement
		9	Rate Impacts
		10	Proposed Changes to Terms and Conditions of Service



SIoux LOOKOUT HYDRO INC.

ONTARIO ENERGY BOARD

IN THE MATTER OF the Ontario Energy Board Act, 1998, being Schedule B to the Energy Competition Act, 1998, S.O. 1998, c.15;

AND IN THE MATTER OF an Application by Sioux Lookout Hydro Inc. ("SLHI") to the Ontario Energy Board for an Order or Orders approving or fixing just and reasonable rates and other service charges for the distribution of electricity commencing May 1, 2008.

APPLICATION

Introduction

The Applicant is Sioux Lookout Hydro Incorporated (referred to in this Application as the "Applicant" or "SLHI"). The Applicant is a corporation incorporated pursuant to the Ontario Business Corporations Act with its head office in the Municipality of Sioux Lookout.

The Applicant hereby applies to the Ontario Energy Board (the "OEB") pursuant to section 78 of the Ontario Energy Board Act, 1998 as amended (the "OEB Act") for approval of its proposed distribution rates and other charges, effective May 1, 2008.

Except where specifically identified in the Application, the Applicant followed Chapter 2 of the Filing Requirements for Transmission and Distribution Applications dated November 14, 2006 (the "Filing Requirements") in preparing this Application.

Proposed Distribution Rates and Other Charges

The Schedule of Rates and Charges proposed in this Application is identified in Exhibit 1 Tab 1, Schedule 5 of this Summary, and the material being filed in support of this Application sets out SLHI's approach to its 2008 distribution rates and charges.

Proposed Effective Date of Rate Order

The Applicant requests that the OEB make its Rate Order effective May 1, 2008 in accordance with the Filing Requirements.

The Proposed Distribution Rates and Other Charges are Just and Reasonable



SIoux LOOKOUT HYDRO INC.

The Applicant submits the proposed distribution rates contained in this Application are just and reasonable on the following grounds:

- I. the proposed rates for the distribution of electricity have been prepared in accordance with the Filing Requirements;
- II. the proposed adjusted rates are necessary to meet the Applicant's Market Based Rate of Return ("MBRR"), Debt Rate and Payments in Lieu of Taxes ("PILs") requirements;
- III. there are no impacts to any of the customer classes or consumption level subgroups that are so significant as to warrant the deferral of any adjustments being requested by the Applicant or the implementation of any other mitigation measures; and
- IV. such other grounds as may be set out in the material accompanying this Application Summary.

Relief Sought

The Applicant applies for an Order or Orders approving the proposed distribution rates and other charges set out in this Application as just and reasonable rates and charges pursuant to section 78 of the OEB Act, to be effective May 1, 2008, or as soon as possible thereafter. If delays are expected in processing the application and issuing a rate order, SLHI is asking for interim rates effective May 1, 2008.

DATED at Sioux Lookout, Ontario, this 2nd day of October, 2007.

Sioux Lookout Hydro Inc.



SIOUX LOOKOUT HYDRO INC.

SUMMARY OF APPLICATION

Purpose and Need

SLHI's revenue requirement for 2008 contemplates the recovery of its costs of providing distribution service; its permitted Return on Equity and the funds necessary to service its debt (based on the OEB's deemed debt/equity ratio which is subject to adjustment this year to move it toward the OEB-mandated 60% debt/40% equity); its Payments in Lieu of Taxes ("PILs"). When its forecasted results for 2008 are taken into account, SLHI estimates that its present rates will produce a deficiency in distribution revenue of \$215,122 for the 2008 Test Year. Excluded from this estimate is the impact of energy costs. The Applicant therefore seeks the Board's approval to revise its rates applicable to its distribution of electricity. The issues to be reviewed in this case, as the applicant sees them, are discussed below.

Through this Application, SLHI seeks to recover Revenue Deficiency in the amount of \$215,122 arising from changes in OM&A, Amortization, Rate of Return, and PILS. The Applicant seeks to discontinue the Recovery of Regulatory Assets charge and recover the Balances of Deferral and Variance Account and credit back the amount of \$101,171. Through this application, SLHI also seeks to update their Distribution Loss Factor bringing them from 1.0547 to 1.0642

SLHI has been assisted in preparing this rate application by Elenchus Research Associates who provided the model used in the determination of just and reasonable 2008 Distribution Rates. The Applicant has based this Application on its forecasted results for the 2008 Test Year. As required by the OEB, the Applicant is also presenting the historical actual information for fiscal 2006; information for the OEB-approved 2006 test year; and six months actual and six months forecast information for the fiscal 2007 bridge year.

Timing

The financial information supporting the Test Year for this Application will be the Applicant's fiscal year ending December 31, 2008 (the "2008 Test Year"). However, this information will be used to set rates for the period May 1, 2008 to April 30, 2009. The Test Year revenue

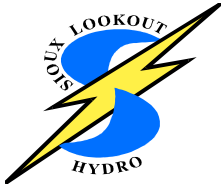

File Number: EB-2007-0785

Exhibit: 1

Tab: 1

Schedule: 3

Page: 2

SIoux LOOKOUT HYDRO INC.

requirement is that forecast by the Applicant as needed to enable it to recover the amounts discussed above for fiscal 2008.

SIoux LOOKOUT HYDRO INC.**Current Rates**

EB-2007-0576

Residential

Service Charge	\$	20.30
Distribution Volumetric Rate	\$/kWh	0.0087
Regulatory Asset Recovery	\$/kWh	0.0106
Retail Transmission Rate – Network Service Rate	\$/kWh	0.0057
Retail Transmission Rate – Line and Transformation Connection Service Rate	\$/kWh	0.0050
Wholesale Market Service Rate	/kWh	0.0052
Rural Rate Protection Charge	\$/kWh	0.0010
Standard Supply Service – Administrative Charge (if applicable)	\$	0.25

General Service Less Than 50 kW

Service Charge	\$	36.05
Distribution Volumetric Rate	\$/kWh	0.0068
Regulatory Asset Recovery	\$/kWh	0.0104
Retail Transmission Rate – Network Service Rate	\$/kWh	0.0052
Retail Transmission Rate – Line and Transformation Connection Service Rate	\$/kWh	0.0045
Wholesale Market Service Rate	/kWh	0.0052
Rural Rate Protection Charge	\$/kWh	0.0010
Standard Supply Service – Administrative Charge (if applicable)	\$	0.25

General Service 50 to 4,999 kW

Service Charge	\$	414.94
Distribution Volumetric Rate	\$/kW	1.4391
Regulatory Asset Recovery	\$/kW	4.2041
Retail Transmission Rate – Network Service Rate	\$/kW	2.1218
Retail Transmission Rate – Line and Transformation Connection Service Rate	\$/kW	1.7882
Retail Transmission Rate – Network Service Rate – Interval Metered	\$/kW	2.2535
Retail Transmission Rate – Line and Transformation Connection Service Rate – Interval Metered	\$/kW	1.9603
Retail Transmission Rate – Network Service Rate – Interval Metered >1,000 kW	\$/kW	2.2508
Retail Transmission Rate – Line and Transformation Connection Service Rate – Interval Metered >1,000 kW	\$/kW	1.9763
Wholesale Market Service Rate	/kWh	0.0052
Rural Rate Protection Charge	\$/kWh	0.0010
Standard Supply Service – Administrative Charge (if applicable)	\$	0.25

Unmetered Scattered Load

Service Charge (per connection)	\$	17.90
Distribution Volumetric Rate	\$/kWh	0.0068
Regulatory Asset Recovery	\$/kWh	0.0104
Retail Transmission Rate – Network Service Rate	\$/kWh	0.0052
Retail Transmission Rate – Line and Transformation Connection Service Rate	\$/kWh	0.0045
Wholesale Market Service Rate	/kWh	0.0052
Rural Rate Protection Charge	\$/kWh	0.0010
Standard Supply Service – Administrative Charge (if applicable)	\$	0.25

Street Lighting

Service Charge (per connection)	\$	0.87
Distribution Volumetric Rate	\$/kW	2.2980
Regulatory Asset Recovery	\$/kW	2.7359
Retail Transmission Rate – Network Service Rate	\$/kW	1.6002
Retail Transmission Rate – Line and Transformation Connection Service Rate	\$/kW	1.3824
Wholesale Market Service Rate	\$/kWh	0.0052
Rural Rate Protection Charge	\$/kWh	0.0010

SIoux LOOKOUT HYDRO INC.

Standard Supply Service – Administrative Charge (if applicable) \$ 0.25

Specific Service Charges

Customer Administration		
Statement of Account	\$	15.00
Duplicate invoices for previous billing	\$	15.00
Easement Letter	\$	15.00
Income tax letter	\$	15.00
Credit reference/credit check (plus credit agency costs)	\$	15.00
Returned cheque charge (plus bank charges)	\$	15.00
Charge to certify cheque	\$	15.00
Account set up charge/change of occupancy charge (plus credit agency costs if applicable)	\$	30.00
Meter dispute charge plus Measurement Canada fees (if meter found correct)	\$	30.00
Non-Payment of Account		
Late Payment - per month	%	1.50
Late Payment - per annum	%	19.56
Collection of account charge – no disconnection	\$	30.00
Disconnect/Reconnect Charge - At Meter during Regular Hours	\$	110.00
Disconnect/Reconnect Charge - At Meter after Regular Hours	\$	245.00
Disconnect/Reconnect at pole – during regular hours	\$	245.00
Disconnect/Reconnect at pole – after regular hours	\$	415.00
Install/Remove load control device – during regular hours	\$	110.00
Install/Remove load control device – after regular hours	\$	245.00
Temporary service – installs and remove – overhead – no transformer	\$	500.00
Temporary service – installs and remove – underground – no transformer	\$	300.00
Temporary service – install and remove – overhead – with transformer	\$	1,000.00
Specific Charge for Access to the Power Poles – per pole/year	\$	22.35
Allowances		
Transformer Allowance for Ownership - per kW of billing demand/month	\$/kW	(0.60)
Primary Metering Allowance for transformer losses – applied to measured demand and energy	%	(1.00)

Loss Factor

Total Loss Factor – Secondary Metered Customer < 5,000 kW	1.0547
Total Loss Factor – Secondary Metered Customer > 5,000 kW	N/A
Total Loss Factor – Primary Metered Customer < 5,000 kW	1.0442
Total Loss Factor – Primary Metered Customer > 5,000 Kw	N/A

SIoux LOOKOUT HYDRO INC.**Proposed Rates****MONTHLY RATES AND CHARGES****Residential**

Service Charge	\$	23.15
Distribution Volumetric Rate	\$/kWh	0.0136
Regulatory Asset Recovery/Disposal	\$/kWh	(0.0003)
Retail Transmission Rate – Network Service Rate	\$/kWh	0.0052
Retail Transmission Rate – Line and Transformation Connection Service Rate	\$/kWh	0.0016
Wholesale Market Service Rate	/kWh	0.0052
Rural Rate Protection Charge	\$/kWh	0.0010
Standard Supply Service – Administrative Charge (if applicable)	\$	0.25

General Service Less Than 50 kW

Service Charge	\$	41.32
Distribution Volumetric Rate	\$/kWh	0.0111
Regulatory Asset Recovery/Disposal	\$/kWh	(0.0003)
Retail Transmission Rate – Network Service Rate	\$/kWh	0.0048
Retail Transmission Rate – Line and Transformation Connection Service Rate	\$/kWh	0.0014
Wholesale Market Service Rate	/kWh	0.0052
Rural Rate Protection Charge	\$/kWh	0.0010
Standard Supply Service – Administrative Charge (if applicable)	\$	0.25

General Service 50 to 4,999 kW

Service Charge	\$	473.17
Distribution Volumetric Rate	\$/kW	2.6784
Regulatory Asset Recovery/Disposal	\$/kWh	(0.1407)
Retail Transmission Rate – Network Service Rate	\$/kW	1.9521
Retail Transmission Rate – Line and Transformation Connection Service Rate	\$/kW	0.5633
Retail Transmission Rate – Network Service Rate – Interval Metered	\$/kW	2.0732
Retail Transmission Rate – Line and Transformation Connection Service Rate – Interval Metered	\$/kW	0.6175
Retail Transmission Rate – Network Service Rate – Interval Metered >1,000 kW	\$/kW	2.0707
Retail Transmission Rate – Line and Transformation Connection Service Rate – Interval Metered >1,000 kW	\$/kW	0.6225
Wholesale Market Service Rate	/kWh	0.0052
Rural Rate Protection Charge	\$/kWh	0.0010
Standard Supply Service – Administrative Charge (if applicable)	\$	0.25

Unmetered Scattered Load

Service Charge (per connection)	\$	20.50
Distribution Volumetric Rate	\$/kWh	0.0111
Regulatory Asset Recovery/Disposal	\$/kWh	0.0003
Retail Transmission Rate – Network Service Rate	\$/kWh	0.0048
Retail Transmission Rate – Line and Transformation Connection Service Rate	\$/kWh	0.0014
Wholesale Market Service Rate	/kWh	0.0052
Rural Rate Protection Charge	\$/kWh	0.0010
Standard Supply Service – Administrative Charge (if applicable)	\$	0.25

Street Lighting

Service Charge (per connection)	\$	0.99
Distribution Volumetric Rate	\$/kW	3.6063
Regulatory Asset Recovery/Disposal	\$/kWh	0.2396
Retail Transmission Rate – Network Service Rate	\$/kW	1.4722
Retail Transmission Rate – Line and Transformation Connection Service Rate	\$/kW	0.4355
Wholesale Market Service Rate	/kWh	0.0052
Rural Rate Protection Charge	\$/kWh	0.0010
Standard Supply Service – Administrative Charge (if applicable)	\$	0.25

SIoux LOOKOUT HYDRO INC.**Specific Service Charges**

Customer Administration		
Statement of Account	\$	15.00
Duplicate invoices for previous billing	\$	15.00
Easement Letter	\$	15.00
Income tax letter	\$	15.00
Credit reference/credit check (plus credit agency costs)	\$	15.00
Returned cheque charge (plus bank charges)	\$	15.00
Charge to certify cheque	\$	15.00
Account set up charge/change of occupancy charge (plus credit agency costs if applicable)	\$	30.00
Meter dispute charge plus Measurement Canada fees (if meter found correct)	\$	30.00
Non-Payment of Account		
Late Payment - per month	%	1.50
Late Payment - per annum	%	19.56
Collection of account charge – no disconnection	\$	30.00
Disconnect/Reconnect Charge - At Meter during Regular Hours	\$	110.00
Disconnect/Reconnect Charge - At Meter after Regular Hours	\$	245.00
Disconnect/Reconnect at pole – during regular hours	\$	245.00
Disconnect/Reconnect at pole – after regular hours	\$	415.00
Install/Remove load control device – during regular hours	\$	110.00
Install/Remove load control device – after regular hours	\$	245.00
Temporary service – installs and remove – overhead – no transformer	\$	500.00
Temporary service – installs and remove – underground – no transformer	\$	300.00
Temporary service – install and remove – overhead – with transformer	\$	1,000.00
Specific Charge for Access to the Power Poles – per pole/year	\$	22.35
Allowances		
Transformer Allowance for Ownership - per kW of billing demand/month /kW		(0.305)
Primary Metering Allowance for transformer losses – applied to measured demand and energy	%	(1.00)

Loss Factor

Total Loss Factor – Secondary Metered Customer < 5,000 kW	1.0642
Total Loss Factor – Secondary Metered Customer > 5,000 kW	1.0145
Total Loss Factor – Primary Metered Customer < 5,000 kW	1.0535
Total Loss Factor – Primary Metered Customer > 5,000 Kw	1.0045

SIOUX LOOKOUT HYDRO INC.**CUSTOMER BILL IMPACT****Residential at 1000kWh/month**

	Metric	2007 BILL			2008 BILL			IMPACT		
		Volume	Rate \$	Charge \$	Volume	Rate \$	Charge \$	Change \$	Change %	% of Total Bill
Monthly Service Charge				20.30			23.15	2.85	14.0%	2.4%
Distribution	kWh	1,000	0.00870	8.70	1,000	0.01360	13.60	4.90	56.3%	4.1%
				29.00			36.75	7.75	26.7%	6.6%
Regulatory Asset Recovery/Disposal	kWh	1,000	0.01060	10.60	1,000	-0.00030	-0.30	-10.90	-102.8%	-9.2%
Retail Transmission - Network	kWh	1,055	0.00570	6.01	1,064	0.00520	5.53	-0.48	-8.0%	-0.4%
Retail Transmission - Line and Transformation Connection	kWh	1,055	0.00500	5.27	1,064	0.00160	1.70	-3.57	-67.7%	-3.0%
Wholesale Market Service	kWh	1,055	0.00520	5.48	1,064	0.00520	5.53	0.05	0.9%	0.0%
Rural Rate Protection Charge	kWh	1,055	0.00100	1.05	1,064	0.00100	1.06	0.01	0.9%	0.0%
Debt Retirement Charge	kWh	1,000	0.00700	7.00	1,000	0.00700	7.00	0.00	0.0%	0.0%
Cost of Power Commodity	kWh	1,055	0.05704	60.16	1,064	0.05704	60.70	0.54	0.9%	0.5%
Total Bill				124.58			117.99	-6.60	-5.3%	-5.6%

In order to increase the fixed cost recovery, SLHI is proposing to increase the monthly customer charge by \$2.97 in the 2008 Test Year.

The impact on a residential customer with 1000kWhs is an increase of 14.6% on the delivery component of the bill. The overall bill impact on a Residential customer is shown in detail in Exhibit 9, Tab 1, Schedule 9.

General Service less than 50kW at 2000kWh/month

	Metric	2007 BILL			2008 BILL			IMPACT		
		Volume	Rate \$	Charge \$	Volume	Rate \$	Charge \$	Change \$	Change %	% of Total Bill
Monthly Service Charge				36.05			41.32	5.27	14.6%	2.3%
Distribution	kWh	2,000	0.00680	13.60	2,000	0.01110	22.20	8.60	63.2%	3.8%
Sub-Total				49.65			63.52	13.87	27.9%	6.2%

SIOUX LOOKOUT HYDRO INC.

Regulatory Asset Recovery/Disposal	kWh	2,000	0.01040	20.80	2,000	-0.00030	-0.60	-21.40	-102.9%	-9.5%
Retail Transmission - Network	kWh	2,109	0.00520	10.97	2,128	0.00480	10.22	-0.75	-6.9%	-0.3%
Retail Transmission - Line and Transformation Connection	kWh	2,109	0.00450	9.49	2,128	0.00140	2.98	-6.51	-68.6%	-2.9%
Wholesale Market Service	kWh	2,109	0.00520	10.97	2,128	0.00520	11.07	0.10	0.9%	0.0%
Rural Rate Protection Charge	kWh	2,109	0.00100	2.11	2,128	0.00100	2.13	0.02	0.9%	0.0%
Debt Retirement Charge	kWh	2,000	0.00700	14.00	2,000	0.00700	14.00	0.00	0.0%	0.0%
Cost of Power Commodity	kWh	2,109	0.05704	120.32	2,128	0.05704	121.40	1.08	0.9%	0.5%
Total Bill				238.31			224.72	-13.59	-5.7%	-6.0%

In order to increase the fixed cost recovery, SLHI is proposing to increase the monthly customer charge by \$5.27 in the 2008 Test Year.

The impact on a General Service customer with 2000kWhs is an increase of 14.6% on the delivery component of the bill. The overall bill impact on a General Service less than 50kW customer is shown in detail in Exhibit 9, Tab 1, Schedule 9.

General Service 50 to 4999kW

	Metric	2007 BILL			2008 BILL			IMPACT		
		Volume	Rate \$	Charge \$	Volume	Rate \$	Charge \$	Change \$	Change %	% of Total Bill
Monthly Service Charge				414.94			473.17	58.23	14.0%	1.5%
Distribution	kW	100	1.43910	143.91	100	2.67840	267.84	123.93	86.1%	3.1%
Sub-Total				558.85			741.01	182.16	32.6%	4.6%
Regulatory Asset Recovery/Disposal	kW	100	4.20410	420.41	100	-0.14070	-14.07	-434.48	-103.3%	-11.0%
Retail Transmission - Network	kW	100	2.12180	212.18	106	1.95210	207.74	-4.44	-2.1%	-0.1%
Retail Transmission - Line and Transformation Connection	kW	100	1.78820	178.82	106	0.56330	59.95	-118.87	-66.5%	-3.0%
Wholesale Market Service	kWh	42,188	0.00520	219.38	42,568	0.00520	221.35	1.98	0.9%	0.0%

SIOUX LOOKOUT HYDRO INC.

Rural Rate Protection Charge	kWh	42,188	0.00100	42.19	42,568	0.00100	42.57	0.38	0.9%	0.0%
Debt Retirement Charge	kWh	40,000	0.00700	280.00	40,000	0.00700	280.00	0.00	0.0%	0.0%
Cost of Power Commodity	kWh	42,188	0.05704	2,406.40	42,568	0.05704	2,428.08	21.68	0.9%	0.5%
Total Bill				4,318.23			3,966.63	-351.60	-8.1%	-8.9%

In order to increase the fixed cost recovery, SLHI is proposing to increase the monthly customer charge by \$60.61 in the 2008 Test Year.

The impact on a General Service 50 to 999kW with 100kW demand and 40,000kWhs customer is a increase of 14.6% on the delivery component of the bill. The overall bill impact on a General Service 50 to 4999kW customer is shown in detail in Exhibit 9, Tab 1, Schedule 9.

Street Lighting

	Metric	2007 BILL			2008 BILL			IMPACT		
		Volume	Rate \$	Charge \$	Volume	Rate \$	Charge \$	Change \$	Change %	% of Total Bill
Monthly Service Charge	kW			0.87			0.99	0.12	13.8%	1.4%
Distribution		1	2.29800	2.30	1	3.60630	3.61	1.31	56.9%	14.8%
Sub-Total	kW			3.17			4.60	1.43	45.1%	16.2%
Regulatory Asset Recovery/Disposal	kW	1	2.73590	2.74	1	0.23960	0.18	-1.87	-91.2%	-25.8%
Retail Transmission - Network	kW	1	1.60020	1.69	1	1.47220	1.18	-0.09	-7.2%	-1.3%
Retail Transmission - Line and Transformation Connection	kW	1	1.38240	1.46	1	0.43550	0.35	-0.75	-68.2%	-10.3%
Wholesale Market Service	kWh	26	0.00520	0.14	27	0.00520	0.14	0.00	0.9%	0.0%
Rural Rate Protection Charge	kWh	26	0.00100	0.03	27	0.00100	0.03	0.00	0.9%	0.0%
Debt Retirement Charge	kWh	25	0.00700	0.18	25	0.00700	0.18	0.00	0.0%	0.0%
Cost of Power Commodity		26	0.05704	1.50	27	0.05704	1.52	0.01	0.9%	0.2%
Total Bill	kW			10.89			7.25	-1.59	-18.0%	-22.0%

In order to increase the fixed cost recovery, SLHI is proposing to increase the monthly customer charge by \$0.12 in the 2008 Test Year.

SIoux LOOKOUT HYDRO INC.

The impact on the Street Light customer with 1kW demand and 25 kWhs is an increase of 13.8% on the delivery component of the bill. The overall bill impact on the Street Light customer is shown in detail in Exhibit 9, Tab 1, Schedule 9.

Unmetered Scattered Load

	Metric	2007 BILL			2008 BILL			IMPACT		
		Volume	Rate \$	Charge \$	Volume	Rate \$	Charge \$	Change \$	Change %	% of Total Bill
Monthly Service Charge	kWh			17.90			20.61	2.71	15.1%	0.9%
Distribution		3,000	0.00680	20.40	3,000	0.01114	33.43	13.03	63.9%	4.4%
Sub-Total	kWh			38.30			54.04	15.74	41.1%	5.3%
Regulatory Asset Recovery/Disposal	kWh	3,000	0.01040	31.20	3,000	0.00030	0.90	-32.01	-97.3%	-10.8%
Retail Transmission - Network	kWh	3,164	0.00520	16.45	3,193	0.00480	15.32	-1.13	-6.9%	-0.4%
Retail Transmission - Line and Transformation Connection	kWh	3,164	0.00450	14.24	3,193	0.00140	4.47	-9.77	-68.6%	-3.3%
Wholesale Market Service	kWh	3,164	0.00520	16.45	3,193	0.00520	16.60	0.15	0.9%	0.0%
Rural Rate Protection Charge	kWh	3,164	0.00100	3.16	3,193	0.00100	3.19	0.03	0.9%	0.0%
Debt Retirement Charge	kWh	3,000	0.00700	21.00	3,000	0.00700	21.00	-1.15	-5.2%	-0.4%
Cost of Power Commodity		3,164	0.05704	180.48	3,193	0.05704	182.11	1.63	0.9%	0.5%
Total Bill	kW			321.29			297.63	-27.63	-8.5%	-9.3%

In order to increase the fixed cost recovery, SLHI is proposing to increase the monthly customer charge by \$2.71 in the 2008 Test Year.

The impact on the Unmetered Scattered Load customer with 3000kW demand is and increase of 15.1% on the delivery component of the bill. The overall bill impact on the Street Light customer is shown in detail in Exhibit 9, Tab 1, Schedule 9.

Loss Factors

	Approved TLF	2008 TLF	Proposed % Change
Total Loss Factor-Secondary Metered Customer <5,000 kW	1.0547	1.0642	90%
Total Loss Factor-Primary Metered Customer <5,000 kW	1.0442	1.0535	89%

SIoux LOOKOUT HYDRO INC.

Changes to the Total Loss Factor are detailed in Exhibit 4, Tab 2, Schedule 9.

SLHI considers its proposed rates to have acceptable impacts on the distribution portion of the customer's bill and therefore SLHI is not proposing any rate mitigation measures.

SIOUX LOOKOUT HYDRO INC.

LIST OF ISSUES

There are a number of issues that, although they may not all be defined as major, are anticipated to be examined in this case. These issues are listed below.

Capital Structure

The Applicant's current deemed capital structure is 50% debt and 50% equity. In its December 20, 2006 Report of the Board on Cost of Capital and 2nd Generation Incentive Regulation for Ontario Electricity Distributors, the OEB mandated a shift to a 60% debt/40% equity ratio for all distributors. Consequently, SLHI is requesting a change in its deemed capital structure. Specifically, SLHI is requesting a move in the deemed equity ratio from 53.3% to 46.7% consistent with the 3 year phase-in of SLHI's capital structure from 50% to 40% equity.

Return on Equity

In addition, SLHI has assumed a return on equity of 8.68% consistent with the methodology outlined in Appendix B of the Report of the Board on Cost of Capital and 2nd Generation Incentive Regulation for Ontario Electricity Distributors dated December 20, 2006. SLHI understands the OEB will be finalizing the return on equity for 2008 rates based on January 2008 market interest rate information.

Capital Expenditures

SLHI continues to expand and reinforce its distribution system in order to meet the demand of new and existing customers in its service territory.

Operating and Maintenance Costs

Operating and maintenance costs have been updated to reflect the impact of inflation and expected changes in costs.

Smart Metering

SIoux LOOKOUT HYDRO INC.

SLHI has not included any costs related to Smart Metering. In decision EB-2007-0576 dated April 12, 2007, the Board approved \$0.25 per month per metered customer. At the present time, it is unclear how Smart Metering costs will be recovered and therefore SLHI requests to be included in any provincial mandate of Smart Metering Costs recovery.

SIoux LOOKOUT HYDRO INC.

SPECIFIC APPROVALS REQUESTED

SLHI requests the following specific approvals:

1. Approval to charge rates effective May 1, 2008 to recover a revenue requirement of \$1,921,709
2. Approval of our Specific Services charges listed in Exhibit 1, Tab 1, schedule 5, page 5
3. Approval of SLHI's proposed change in capital structure involving the shift in deemed common equity component from 53.3% to 46.7% (Exhibit 6), consistent with the Report of the Board on Cost of Capital and 2nd Generation Incentive Regulation for Ontario's Electricity Distributors dated December 20, 2006.
4. Approval of the proposed lost factor in Exhibit 4, Tab 2, Schedule 9.
5. Approval to continue the following deferral/variance accounts on May 1, 2008
 - 1505 Un-recovered Plant and Regulatory Study Costs
 - 1508 Other Regulatory Assets
 - 1510 Preliminary Survey and Investigation Charges
 - 1515 Emission Allowance Inventory
 - 1516 Emission Allowances Withheld
 - 1518 Retail Cost Variance Account – Retail
 - 1520 Power Purchase Variance Account
 - 1525 Miscellaneous Deferred Debits – including Rebate Cheques
 - 1530 Deferred Losses from Disposition of Utility Plant
 - 1540 Unamortized Loss on Re-acquired Debt
 - 1545 Development Charge Deposits/Receivables
 - 1548 Retail Cost Variance Account – STR
 - 1550 LV Variance Account
 - 1555 Smart Meter Capital Variance Account
 - 1556 Smart Meters OM&A Variance Account
 - 1560 Deferred Development Cost
 - 1562 Deferred Payments in Lieu of Taxes
 - 1563 PILS Contra Account
 - 1565 CMD Expenditure and Recoveries

SIoux LOOKOUT HYDRO INC.

- 1566 CDM Contra Account
- 1570 Qualifying Transition Costs
- 1571 Pre-Market Opening Energy Variances Total
- 1572 Extra-Ordinary Event Losses
- 1574 Deferred Rate Impact Amounts
- 1580 RSVA-Wholesale Market Service Charge
- 1582 RSVA-One-time Wholesale Market Service
- 1584 RSVA-Retail Transmission Network Charge
- 1586 RSVA-Retail Transmission Connection Charge
- 1588 RSVA-Power
- 1592 Deferred PILs Account
- 2425 Other Deferred Credits

SIoux LOOKOUT HYDRO INC.**REVENUE DEFICIENCY/SUFFICIENCY**
2008 TEST YEAR

	2008 Test Existing Rates	2008 Test Proposed Rates
Revenue		
Suff/ Def From Below.		215,122
Distribution Revenue	1,532,447	1,532,447
Other Operating Revenue (Net)	174,140	174,140
Total Revenue	<u>1,706,587</u>	<u>1,921,709</u>
Distribution Costs		
Operation, Maintenance, and Administration	1,145,527	1,145,527
Depreciation & Amortization	257,984	257,984
Capital Tax		0
Interest- Deemed Interest	203,865	203,865
Total Costs and Expenses	<u>1,607,376</u>	<u>1,607,376</u>
Utility Income Before Income Taxes	99,211	314,333
Net Adjustments per 2008 Pils	<u>-7,658</u>	<u>-7,658</u>
	91,553	306,675
Income Tax (Tax Rate 17%)	15,564	52,135
Utility Income	<u>83,647</u>	<u>262,198</u>
Rate Base	6,470,658	6,470,658
Equity	0.4667	0.4667
Equity Component Rate Base	3,019,640	3,019,640
Income / Equity Rate Base %	2.77%	8.68%
Target Return -Equity on Rate Base	8.68%	8.68%

SIoux LOOKOUT HYDRO INC.

Return- Equity on Rate Base	262,198	262,198
Revenue Deficiency	178,551	
Revenue Deficiency (Gross-up)	215,122	

SIoux LOOKOUT HYDRO INC.

CAUSES OF REVENUE DEFFICIENCY

The increase in SLHI's distribution expenses including depreciation expense in the 2008 Test Year of \$1,403,511 is a result of normal operating expenses plus inflation plus additional amortization related to the Capital program at SLHI

The change in SLHI's return on capital in the 2008 Test Year of \$466,064 indicated that the utility was not earning its regulated return based on 2006 EDR which is based on 2004 actual.

The change in SLHI's PILs in the 2008 Test Year of \$52,135 relative to the estimated amount to be collected based on decreased tax rates and increased revenue

SIoux LOOKOUT HYDRO INC.

BOARD FINDINGS AND DIRECTIONS FROM 2007 EDR

Excerpt from Decision and Order issued April 12, 2007

Sioux Lookout's rate application was filed on the basis of the guidelines. In fixing new rates and charges for Sioux Lookout, the Board has applied the policies described in the Report.

After confirming the accuracy of the 2006 rate tariff and accompanying materials submitted in the rate application, the Board applied its approved price cap index adjustment to distribution rates (fixed and variable) uniformly across all customer classes. The price cap index is calculated as a price escalator less an X-factor of 1.0%, intended to represent input price and productivity trends. Based on the final 2006 data published by Statistics Canada, the Board has established the price escalator to be 1.9%. The resulting price cap index adjustment is therefore 0.9%.

The price cap index adjustment was not applied to the following components of the rates:

- the specific service charges;
- the regulatory asset recovery rate rider; and
- the smart meter rate adder (an amount in the fixed components of the rates associated with smart meter cost recovery).

Sioux Lookout requested an amount for smart meter costs. The Board has approved an amount of \$0.25 per month per metered customer. Sioux Lookout's variance accounts for smart meter program implementation costs, previously authorized by the Board, are continued. It is the Board's understanding that Sioux Lookout will not be undertaking any smart metering activity (i.e. discretionary metering activity) in 2007. The amount collected through the smart meter rate adder will be booked into the existing variance accounts, and retained in those accounts, to help fund future smart meter activity. As the notice of this application indicated, the Board will be holding a combined proceeding to consider, among other things, appropriate recovery of smart meter costs.

In compliance with the Board's instruction in the Decision and Order RP-2005-0020/EB-2005-0415 issued April 12, 2006, Sioux Lookout filed a report on Low Voltage ("LV") charge

SIoux LOOKOUT HYDRO INC.

recoveries and account balances related to bill impact mitigation approved by the Board in that Decision and Order.

Sioux Lookout recommended that no adjustment be made to 2007 rates to mitigate the impact of the 2006 LV charges from Hydro One Networks Inc. The Board accepts Sioux Lookout's report and recommendations. The Board directs Sioux Lookout to file an updated report on LV recoveries and account balances in its next distribution rate application.

The Board notes that Sioux Lookout has over-collected Retail Transmission Services amounts as shown by the credit balance of \$922,613 in the variance account 1586, and currently is under-recovering for the LV charges levied by Hydro One Networks Inc. The Board directs Sioux Lookout to file a detailed plan in its next cost of service rate application to address the insufficiency in its revenue requirement to recover ongoing LV charges from Hydro One Networks Inc. and the over-collection in Sioux Lookout's Retail Transmission Service rates.

The Board has made the necessary adjustments to Sioux Lookout's filed 2006 Tariff of Rates and Charges to produce a new Tariff of Rates and Charges to be effective May 1, 2007. The Board finds the rates and charges in the Tariff of Rates and Charges attached as Appendix A to this decision to be just and reasonable.

THE BOARD ORDERS THAT:

1. The Tariff of Rates and Charges set out in Appendix A of this order is approved, effective May 1, 2007, for electricity consumed or estimated to have been consumed on and after May 1, 2007.
2. The Tariff of Rates and Charges set out in Appendix A of this order supersedes all previous distribution rate schedules approved by the Ontario Energy Board for Sioux Lookout, and is final in all respects.

SIoux LOOKOUT HYDRO INC.

3. Sioux Lookout shall notify its customers of the rate changes no later than with the first bill reflecting the new rates.
4. Sioux Lookout shall file a report on the Low Voltage charge recoveries and the balances of applicable accounts according to the Board's Uniform System of Accounts in its next distribution rate application.
5. In its next cost of service rate application, Sioux Lookout shall file a detailed plan proposing a remedy for its under-collection of ongoing Low Voltage charges levied on it by Hydro One Networks Inc., and a remedy for its over-collection of Retail Transmission Service charges.

SIoux LOOKOUT HYDRO INC.

BOARD FINDINGS AND DIRECTIONS FROM 2006 EDR

Excerpt from Decision and Order issued April 12, 2007

In its preliminary review of the 2006 rate applications received from the distributors, the Board identified several issues that appeared to be common to many or all of the distributors. As a result, the Board held a hearing (EB-2005-0529) to consider these issues (the "Generic Issues Proceeding") and released its decision (the "Generic Decision") on March 21, 2006. The rulings flowing from that Generic Decision apply to this Application, except to the extent noted in this Decision. The Board notes that pursuant to ss. 21 (6.1) of the *Ontario Energy Board Act, 1998*, and to the extent that it is pertinent to this Application, the evidentiary record of the Generic Issues Proceeding is part of the evidentiary record upon which the Board is basing this Decision.

In December 2001, the Board authorized the establishment of deferral accounts by the distributors related to the payments that the distributors make to the Ministry of Finance in lieu of taxes. The Board is required, under its enabling legislation, to make an order with respect to non-commodity deferral accounts once every twelve months. The Board has considered the information available with respect to these accounts and orders that the amounts recorded in the accounts will not be reflected in rates as part of the Rate Order that will result from this Decision. The Board will continue to monitor the accounts with a view to clearing them when appropriate.

Public notice of the rate Application made by SLH was given through newspaper publication in its service area. The evidence filed was made available to the public. Interested parties intervened in the proceeding. The evidence in the Application was tested through written interrogatories from Board staff and intervenors, and intervenors and SLH had the opportunity to file written argument. While the Board has considered the entire record in this proceeding, it has made reference in this Decision only to such evidence and argument as is necessary to provide context to its findings.

SLH has requested an amount of \$2,548,188 as revenue to be recovered through distribution rates and charges. Included in this amount is a debit of \$927,574 for the recovery of

SIoux LOOKOUT HYDRO INC.

regulatory assets. Except where noted in this Decision, the Board finds that SLH has filed its Application in accordance with the Handbook and the guidelines for the recovery of regulatory assets.

Notwithstanding SLH's general compliance with the Handbook and associated models, in considering this Application the Board reviewed the following matters in detail:

- Post-2004 Interest on Regulatory Asset balances;
- Bill Impact Mitigation;
- Low Voltage Rates; and
- Consequences of the Generic Decision (EB-2005-0529).

Post-2004 Interest on Regulatory Asset Balances

In its original application, Sioux Lookout omitted carrying charges for the period January 1, 2005 to April 30, 2006 on the December 31, 2004 balances of Regulatory Asset accounts. In response to Board staff interrogatories, the Applicant submitted a revised Regulatory Asset spreadsheet including calculated interest.

The Board notes that the resulting amounts appear to have been calculated using interest rates different than those approved by the Board. However, the debit and credit amounts are offsetting and if corrected would result in a slightly higher revenue requirement, thus acting against the Applicant's rate mitigation efforts. As a result the Board will accept the post-2004 carrying charges as filed.

Bill Impact Mitigation

In its original application, SLH proposed to mitigate bill impacts on its customers by reducing by 50% the recovery of Hydro One Networks' Regulatory Asset costs assigned to SLH by the Board's letter of July 25, 2005 for the period January 1, 2004 to April 30, 2006. On October 18, 2005, Sioux Lookout filed an amended application whereby the recovery of those costs in rate riders would be reduced by 30%. In response to a Board staff interrogatory, the Applicant indicated that it proposed to seek recovery of the amount not being collected in a

SIoux LOOKOUT HYDRO INC.

subsequent rate application. The Applicant is thus proposing to extend the period of Regulatory Asset recovery beyond 2007.

In general, distribution utilities should recover approved regulatory assets over a short time frame, typically four years, to avoid intergenerational inequities and to reduce associated interest costs. However, the Board acknowledges that depending on a utility's circumstances, recovery over a longer period may be appropriate and necessary to avoid "rate shock". The Board finds SLH's proposal to mitigate bill impacts in 2006 by extending the period for recovery of Hydro One Networks' Regulatory Assets charged to SLH by an additional year to be reasonable. The Applicant is instructed to document its recoveries and the outstanding amounts in subsequent distribution rate applications until the mitigated amount is fully recovered.

Low Voltage Rates

As noted in the Application, SLH is an embedded distributor. Hydro One Networks, the "host" distributor, provides Low Voltage wheeling distribution services to transport energy from the transmission network to SLH's distribution network for delivery to SLH's retail customers. Hydro One Networks applied and received approval for new LV rates effective May 1, 2006, that they will levy on embedded distributors for Low Voltage wheeling services and the use of assets required to provide these services.

The Handbook allows an embedded distributor to include, as part of its application for 2006 distribution rates, the estimated LV charges that the embedded distributor would be charged by its host distributor(s). SLH did not include an estimate for this amount in its Application. In response to interrogatories from Board staff and from the School Energy Coalition ("SEC"), SLH stated that it wishes to purchase from Hydro One Networks the distribution station and associated assets through which LV services are provided. Should SLH purchase these assets, it states that it will no longer be embedded in Hydro One Networks LV system or subject to Hydro One Networks' LV charges. SLH stated that LV charges levied on it are significant due to its geographic circumstances. SLH's rate base and operating expenses would increase somewhat if it were to acquire the assets, but the Applicant noted that it is currently underleveraged and would use debt to finance the acquisition. This would move its

SIOUX LOOKOUT HYDRO INC.

capital structure closer to the deemed capital structure that the Board has determined to be generally appropriate for an electricity distributor of SLH's size. Any increase in rate base and operating expenses would be offset, wholly or partially, by elimination of ongoing LV charges. SEC supported SLH's efforts to acquire the Hydro One Networks assets and avoid LV charges.

The Board notes that it is up to SLH to negotiate an acceptable transaction with Hydro One Networks. Any such agreement for the sale of distribution assets by Hydro One Networks would be subject to Board review upon application, pursuant to ss. 86 of the *Ontario Energy Board Act, 1998*. The Board instructs SLH to report, in its next rate application, on the progress or outcome of attempts to negotiate a purchase of the distribution assets from Hydro One Networks. SLH should contact Board staff to discuss this matter if issues arise.

Absent this acquisition, SLH will continue to be subject to LV charges from Hydro One Networks. The Board will accept the non-recovery of ongoing LV charges at this time as part of the Applicant's mitigation proposal. As set out in the Generic Decision, SLH will track in a variance account the differences between the LV charges it incurs and the amount it recovers. SLH is directed to report on the balance of the variance account in its next rate application, where the Board will review and determine the disposition of the charges recorded. Should SLH face financial difficulty that would pose a serious risk to its financial viability, or to the maintenance of safe and reliable distribution operations, SLH should inform the Board immediately.

Consequences of the Generic Decision on this Application

The Generic Decision contains findings relevant to funding for smart meters for electricity distributors. The Applicant did not file a specific smart meter investment plan or request approval of any associated amount in revenue requirement. Absent a specific plan or discrete revenue requirement, the Generic Decision provides that \$0.30 per residential customer per month be reflected in the Applicant's revenue requirement. The Board finds that this increase in the revenue requirement amount will be allocated equally to all metered customers and recovered through their monthly service charge. This increment is reflected in the approved monthly service charges contained in the Tariff of Rates and Charges

SIoux LOOKOUT HYDRO INC.

appended to this Decision. Pursuant to the Generic Decision, a variance account will be established, the details of which will be communicated in due course.

Resulting Revenue Requirement

As a result of the Board's determinations on these issues, the Board has adjusted the revenue requirement to be recovered through distribution rates and charges to \$2,556,421, including a debit amount of \$927,574 for the recovery of Regulatory Assets. In its letter of December 20, 2004 to electricity distributors, the Board indicated that it would consider the disposition of the 2005 OEB dues recorded in Account 1508 in this proceeding. However, given that the final 2005 OEB dues are not available because of the difference in fiscal years for the Board and the distributors, and given that the model used to develop the Application does not incorporate this provision, the Board will review and dispose of the 2005 OEB dues at a later time.

SIoux LOOKOUT HYDRO INC.

STATUS REPORT ON BOARD DIRECTIVES

Subsequent to the report sent to the Board on March 15, 2007, to address the mitigation of Hydro One Charges in the 2006 EDR application, an amount of \$384,051 has been included in the application for Recovery of Regulatory Asset balances under account 1550. This amount includes a credit of \$1,822,785 to record the amount approved to be recovered in the 2006 EDR that was transferred to account 1590, plus the January 2007 to April 2007 regulatory asset payments made to hydro one of \$260,424. It also includes payments to be made to Hydro One for the balance of the regulatory assets, not previously included in the 2006 EDR.(see the DVAD model.). Therefore SLHI has applied for full recovery of the balance of the Hydro One Charges in this application.

SLHI did not apply to recover any LV charges in its 2006 EDR. This application includes an estimate of \$340,000 in its revenue requirement to be recovered for LV charges. This figure is based on an average of \$28,340 paid for LV charges per month in the last year.

To address the over-collection of Connection charges, SLHI proposes to decrease the connection charges as per the proposed rate schedule. A credit of \$655,907 is included account 1586 to be disposed in this application. The impact of this figure will be a credit amount for the 2008 rate rider in most cases.

Through this application, SLHI is also proposing to readjust their Retail transmission charges. Calculations of these adjustments are found in Exhibit 4, Tab 2, Schedule 11.

SIoux LOOKOUT HYDRO INC.

UNIFORM SYSTEM OF ACCOUNTS AND ACCOUNTING ORDERS

SLHI is in compliance with the OEB's Uniform System of Accounts for electricity distributors and, where applicable, with the OEB's related accounting letters and orders.

SIoux LOOKOUT HYDRO INC.

UTILITY DESCRIPTION

Overview

Sioux Lookout Hydro Incorporated ("SLHI") is the electricity distributor licensed by the Ontario Energy Board to serve the Municipality of Sioux Lookout. SLHI and other affiliates of SLHI were incorporated under the *Business Corporations Act* (Ontario) on June 23, 1999. The sole shareholder of SLHI is the Municipality of Sioux Lookout. The Municipality owns 100 percent of the shares of SLHI. The Applicant's long term debt is held entirely by the CIBC bank.

SLHI operates an electrical distribution system with a total service area of 536 square kilometers within the Municipality of Sioux Lookout. The Company currently delivers electricity through a network of over 205 kilometers of overhead wires, through transformer stations, to approximately 2750 customers in residential, general service classes. SLHI's distribution revenue in 2006 was \$1,504,264.75 million. SLHI employs a full-time workforce of 7 skilled employees who are dedicated to delivering a safe and reliable supply of electricity to customers.

Neighbouring Utilities

The Company has one adjacent distributor which is Hydro One.

Host or Embedded Utilities

SLHI is not a host utility and there are no embedded utilities in SHLI's distribution service area.

Contact Information

SIoux LOOKOUT HYDRO INCORPORATED

25 FIFTH AVE., P.O. BOX 908

SIoux LOOKOUT, ON P8T 1B3

Deanne Kulchyski

SIoux LOOKOUT HYDRO INC.

Financial & Regulatory Affairs Officer

Phone: 807-737-3800

Fax: 807-737-2832

e-mail : slhydro@tbaytel.net

File Number: EB-2007-0785

Exhibit: 1

Tab: 2

Schedule: 2

Page: 1

SIoux LOOKOUT HYDRO INC.

DISTRIBUTOR LICENCE

Rep: OEB
Doc: 12MDM
Rev: 1



Electricity Distribution Licence

ED-2002-0514

Sioux Lookout Hydro Inc.

Valid Until

March 31, 2023

Mark C. Garner
Director of Licensing
Ontario Energy Board

Date of Issuance: May 21, 2003

Ontario Energy Board
P.O. Box 2319
2300 Yonge Street
26th. Floor
Toronto, ON M4P 1E4

Commission de l'Énergie de l'Ontario
C.P. 2319 2300, rue Yonge 26e étage
Toronto ON M4P 1E4

Electricity Distribution Licence	[2]
1 Definitions	[3]
2 Interpretation	[21]
3 Authorization Granted under this Licence	[23]
4 Obligation to Comply with Legislation, Regulations and Market Rules	[28]
5 Obligation to Comply with Codes	[31]
6 Obligation to Provide Non-discriminatory Access	[40]
7 Obligation to Connect	[42]
8 Obligation to Sell Electricity	[51]
9 Obligation to Maintain System Integrity	[53]
10 Market Power Mitigation Rebates	[55]
11 Distribution Rates	[57]
12 Separation of Business Activities	[59]
13 Expansion of Distribution System	[61]
14 Provision of Information to the Board and Director of Licensing	[64]

15	Restrictions on Provision of Information	[67]
16	Customer Complaint and Dispute Resolution	[77]
17	Term of Licence	[84]
18	Transfer of Licence	[86]
19	Amendment of Licence	[88]
20	Fees and Assessments	[90]
21	Communication	[92]
22	Copies of the Licence	[99]
Schedule 1	Definition of Distribution Service Area	[103]
Schedule 2	Provision of Standard Supply Service	[106]
Schedule 3	List of Code Exemptions	[109]
Appendix A	Market Power Mitigation Rebates	[112]

Electricity Distribution Licence

1 Definitions

In this Licence:

"Accounting Procedures Handbook" means the handbook, approved by the Board which specifies the accounting records, accounting principles and accounting separation standards to be followed by the Licensee;

"Act" means the Ontario Energy Board Act, 1998, S.O. 1998, c. 15, Schedule B, as amended;

"Affiliate Relationships Code for Electricity Distributors and Transmitters" means the code, approved by the Board which, among other things, establishes the standards and conditions for the interaction between electricity distributors or transmitters and their respective affiliated companies;

"Board" means the Ontario Energy Board;

"Director" means the Director of Licensing appointed under section 5 of the *Act*;

"distribution services" means services related to the distribution of electricity and the services the Board has required distributors to carry out, including the sales of electricity to consumers under section 29 of the *Act*, for which a charge or rate has been established in the Rate Order;

"Distribution System Code" means the code approved by the Board which, among other things, establishes the obligations of the distributor with respect to the services and terms of service to be offered to customers and retailers and provides minimum, technical operating standards of distribution systems;

"Electricity Act" means the *Electricity Act, 1998*, S.O. 1998, c. 15, Schedule A, as amended;

"Licensee" means Sioux Lookout Hydro Inc.;

"Market Rules" means the rules made under section 32 of the *Electricity Act*;

"Performance Standards" means the performance targets for the distribution and connection activities of

the Licensee as established by the Board in accordance with section 83 of the *Act*;

"Rate Order" means an Order or Orders of the Board establishing rates the Licensee is permitted to charge;

"Retail Settlement Code" means the code approved by the Board which, among other things, establishes a distributor's obligations and responsibilities associated with financial settlement among retailers and consumers and provides for tracking and facilitating consumer transfers among competitive retailers;

"service area" with respect to a distributor, means the area in which the distributor is authorized by its licence to distribute electricity;

"Standard Supply Service Code" means the code approved by the Board which, among other things, establishes the minimum conditions that a distributor must meet in carrying out its obligations to sell electricity under section 29 of the *Electricity Act*;

"wholesaler" means a person that purchases electricity or ancillary services in the IMO-administered markets or directly from a generator or, a person who sells electricity or ancillary services through the IMO-administered markets or directly to another person other than a consumer.

2 Interpretation

2.1 In this Licence words and phrases shall have the meaning ascribed to them in the *Act* or the *Electricity Act*. Words or phrases importing the singular shall include the plural and vice versa. Headings are for convenience only and shall not affect the interpretation of the licence. Any reference to a document or a provision of a document includes an amendment or supplement to, or a replacement of, that document or that provision of that document. In the computation of time under this licence where there is a reference to a number of days between two events, they shall be counted by excluding the day on which the first event happens and including the day on which the second event happens and where the time for doing an act expires on a holiday, the act may be done on the next day.

3 Authorization Granted under this Licence

3.1 The Licensee is authorized, under Part V of the *Act* and subject to the terms and conditions set out in this Licence:

- a) To own and operate a distribution system in the service area described in Schedule 1 of this Licence;

b)	To retail electricity for the purposes of fulfilling its obligation under section 29 of the <i>Electricity Act</i> in the manner specified in Schedule 2 of this Licence; and ,	26
c)	To act as a wholesaler for the purposes of fulfilling its obligations under the Retail Settlement Code or under section 29 of the <i>Electricity Act</i> .	27
4	Obligation to Comply with Legislation, Regulations and Market Rules	28
4.1	The Licensee shall comply with all applicable provisions of the <i>Act</i> and the <i>Electricity Act</i> and regulations under these Acts except where the Licensee has been exempted from such compliance by regulation.	29
4.2	The Licensee shall comply with all applicable Market Rules.	30
5	Obligation to Comply with Codes	31
5.1	The Licensee shall at all times comply with the following Codes (collectively the "Codes") approved by the board, except where the Licensee has been specifically exempted from such compliance by the Board. Any exemptions to this requirement are set out in Schedule 3 of this Licence:	32
a)	the Affiliate Relationships Code for Electricity Distributors and Transmitters;	33
b)	the Distribution System Code;	34
c)	the Retail Settlement Code, and;	35
d)	the Standard Supply Service Code.	36
5.2	The Licensee shall:	37
a)	Make a copy of the Codes available for inspection by members of the public at its head office and regional offices during normal business hours and;	38
b)	Provide a copy of the Codes to any person who requests it. The Licensee may impose a fair and reasonable charge for the cost of providing copies.	39
		40

6 Obligation to Provide Non-discriminatory Access

- 6.1 The Licensee shall, upon the request of a consumer, generator or retailer, provide such consumer, generator or retailer with access to the Licensee's distribution system and shall convey electricity on behalf of such consumer, generator or retailer in accordance with the terms of this Licence.

7 Obligation to Connect

- 7.1 The Licensee shall connect a building to its distribution system if:

- a) The building lies along any of the lines of the distributor's distribution system, and
- b) The owner, occupant or other person in charge of the building requests the connection in writing.

- 7.2 The Licensee shall make an offer to connect a building to its distribution system if:

- a) The building is within the Licensee's service area as described in Schedule 1, and
- b) The owner, occupant or other person in charge of the building requests the connection in writing.

- 7.3 The terms of such connection or offer to connect shall be fair and reasonable and made in accordance with the Distribution System Code, and the Licensee's Rate Order as approved by the Board.

- 7.4 The Licensee shall not refuse to connect or refuse to make an offer to connect unless it is permitted to do so by the *Act* or any Codes to which the Licensee is obligated to comply with as a condition of this Licence.

8 Obligation to Sell Electricity

- 8.1 The Licensee shall fulfill its obligation under section 29 of the *Electricity Act* to sell electricity in accordance with the requirements established in the Standard Supply Service Code, the Retail

Settlement Code and the Licensee's Rate Order as approved by the Board.

9 Obligation to Maintain System Integrity

- 9.1 The Licensee shall maintain its distribution system to the standards established in the Distribution System Code, Market Rules and have regard to any other recognized industry operating or planning standards adopted by the Board.

10 Market Power Mitigation Rebates

- 10.1 The Licensee shall comply with the pass through of Ontario Power Generation rebate conditions set out in Appendix A of this Licence.

11 Distribution Rates

- 11.1 The Licensee shall not charge for connection to the distribution system, the distribution of electricity or the retailing of electricity to meet its obligation under section 29 of the *Electricity Act* except in accordance with a Rate Order of the Board.

12 Separation of Business Activities

- 12.1 The Licensee shall keep financial records associated with distributing electricity separate from its financial records associated with transmitting electricity or other activities in accordance with the Accounting Procedures Handbook and as otherwise required by the Board.

13 Expansion of Distribution System

- 13.1 The Licensee shall not construct, expand or reinforce an electricity distribution system or make and interconnection except in accordance with the *Act* and Regulations, the Distribution System Code and applicable provisions of the Market Rules.

- 13.2 In order to ensure and maintain system integrity or reliable and adequate capacity and supply of electricity, the Board may order the Licensee to expand or reinforce its distribution system in accordance with Market Rules and the Distribution System Code, or in such a manner as the Board may determine.

53

54

55

56

57

58

59

60

61

62

63

64

14 Provision of Information to the Board and Director of Licensing

- 14.1 The Licensee shall maintain records of and provide, in the manner and form determined by the Board or the Director, such information as the Board or the Director may require from time to time. 65
- 14.2 Without limiting the generality of condition 14.1 the Licensee shall notify the Director of any material change in circumstances that adversely affects or is likely to adversely affect the business, operations or assets of the Licensee as soon as practicable, but in any event no more than twenty (20) days past the date upon which such change occurs. 66

15 Restrictions on Provision of Information

- 15.1 The Licensee shall not use information regarding a consumer, retailer, wholesaler or generator obtained for one purpose for any other purpose without the written consent of the consumer, retailer, wholesaler or generator. 67
- 15.2 The Licensee shall not disclose information regarding a consumer, retailer, wholesaler or generator to any other party without the written consent of the consumer, retailer, wholesaler or generator, except where such information is required to be disclosed: 68
- a) to comply with any legislative or regulatory requirements, including the conditions of this Licence; 70
 - b) for billing, settlement or market operations purposes; 71
 - c) for law enforcement purposes; or 72
 - d) to a debt collection agency for the processing of past due accounts of the consumer, retailer, wholesaler or generator. 73
- 15.3 The Licensee may disclose information regarding consumers, retailers, wholesalers or generators where the information has been sufficiently aggregated such that their particular information cannot reasonably be identified. 74
- 15.4 The Licensee shall inform consumers, retailers, wholesalers and generators of the conditions under which their information may be released to a third party without their consent. 75

15.5	If the Licensee discloses information under this section, the Licensee shall ensure that the information provided will not be used for any other purpose except the purpose for which it was disclosed.	76
16	Customer Complaint and Dispute Resolution	77
16.1	The Licensee shall:	78
a)	have a process for resolving disputes with customers that deals with disputes in a fair, reasonable and timely manner;	79
b)	publish information which will make its customers aware of and help them to use its dispute resolution process;	80
c)	make a copy of the dispute resolution process available for inspection by members of the public at each of the Licensee’s premises during normal business hours;	81
d)	give or send free of charge a copy of the process to any person who reasonably requests it; and	82
e)	refer unresolved complaints and subscribe to an independent third party complaints resolution service provider selected by the Board. This condition will become effective on a date to be determined by the Director. The Director will provide reasonable notice to the Licensee of the date this condition becomes effective.	83
17	Term of Licence	84
17.1	This Licence shall take effect on May 21, 2003 and terminate on March 31, 2023.	85
18	Transfer of Licence	86
18.1	In accordance with subsection 18(2) of the <i>Act</i> , this Licence is not transferable or assignable without leave of the Board.	87
19	Amendment of Licence	88

19.1	The Board may amend this Licence in accordance with section 74 of the <i>Act</i> or section 38 of the <i>Electricity Act</i> .	89
20	Fees and Assessments	90
20.1	The Licensee shall pay all fees charged and amounts assessed by the Board.	91
21	Communication	92
21.1	The Licensee shall designate a person that will act as a primary contact with the Director of Licensing on matters related to this Licence. The Licensee shall notify the Director promptly should the contact details change.	93
21.2	All official communication relating to this Licence shall be in writing.	94
21.3	All written communication is to be regarded as having been given by the sender and received by the addressee:	95
a)	when delivered in person to the addressee by hand, by registered mail or by courier;	96
b)	seven (7) business days after the date of posting if the communication is sent by regular mail; and,	97
c)	when received by facsimile transmission by the addressee, according to the sender's transmission report.	98
22	Copies of the Licence	99
22.1	The Licensee shall:	100
a)	make a copy of this Licence available for inspection by members of the public at its head office and regional offices during normal business hours and;	101

- b) provide a copy of the Licence to any person who requests it. The Licensee may impose a fair and reasonable charge for the cost of providing copies.

Schedule 1 Definition of Distribution Service Area

103

This Schedule specifies the area in which the Licensee is authorized to distribute and sell electricity in accordance with condition 8 of this Licence.

104

The Municipality of Sioux Lookout as at January 1, 1998.

105

Schedule 2 Provision of Standard Supply Service

106

This Schedule specifies the manner in which the Licensee is authorized to retail electricity for the purposes of fulfilling its obligation under section 29 of the *Electricity Act*.

107

The Licensee is authorized to retail electricity directly to consumers within its service area in accordance with condition 8 of this Licence, any applicable exemptions to this Licence, and at the rates set out in the Rate Orders.

108

Schedule 3 List of Code Exemptions

109

This Schedule specifies any specific Code requirements from which the Licensee has been exempt.

110

The Licensee is exempt from the requirements of section 2.5.3 of the Standard Supply Service Code with respect to the price for small volume/residential consumers, subject to the Licensee offering an equal billing plan as described in its application for exemption from Fixed Reference Price, and meeting all other undertakings and material representations contained in the application and the materials filed in connection with it.

111

Appendix A Market Power Mitigation Rebates

1 Definitions and Interpretation

In this Licence,

"embedded distributor" means a distributor who is not a market participant and to whom a host distributor distributes electricity;

"embedded generator" means a generator who is not a market participant and whose generation facility is connected to a distribution system of a distributor, but does not include a generator who consumes more electricity than it generates;

"host distributor" means a distributor who is a market participant and who distributes electricity to another distributor who is not a market participant.

In this Licence, a reference to the payment of a rebate amount by the IMO includes interim payments made by the IMO.

2 Information Given to IMO

a Prior to the payment of a rebate amount by the IMO to a distributor, the distributor shall provide the IMO, in the form specified by the IMO and before the expiry of the period specified by the IMO, with information in respect of the volumes of electricity withdrawn by the distributor from the IMO-controlled grid during the rebate period and distributed by the distributor in the distributor's service area to:

i consumers served by a retailer where a service transaction request as defined in the Retail Settlement Code has been implemented; and

ii consumers other than consumers referred to in clause (i) who are not receiving the fixed price under sections 79.4 and 79.5 of the *Ontario Energy Board Act, 1998*.

b Prior to the payment of a rebate amount by the IMO to a distributor which relates to electricity consumed in the service area of an embedded distributor, the embedded distributor shall provide the host distributor, in the form specified by the IMO and before the expiry of the period specified in the Retail Settlement Code, with the volumes of electricity distributed during the rebate period by the embedded distributor's host distributor to the embedded distributor net of

c embedded distributors to whom the distributor distributes electricity.

133

The amounts paid out to the recipients listed above shall be based on energy consumed and calculated in accordance with the rules set out in the Retail Settlement Code. These payments may be made by way of set off at the option of the distributor.

134

If requested in writing by OPGI, the distributor shall ensure that all rebates are identified as coming from OPGI in the following form on or with each applicable bill or settlement statement:

135

"ONTARIO POWER GENERATION INC. rebate"

136

Any rebate amount which cannot be distributed as provided above or which is returned by a retailer to the distributor in accordance with its licence shall be promptly returned to the host distributor or IMO as applicable, together with interest at the Prime Rate, calculated and accrued daily, on such amount from the date of receipt.

137

Nothing shall preclude an agreement whereby a consumer assigns the benefit of a rebate payment to a retailer or another party.

138

Pending pass-through or return to the IMO of any rebate received, the distributor shall hold the funds received in trust for the beneficiaries thereof in a segregated account.

139

File Number: EB-2007-0785

Exhibit: 1

Tab: 2

Schedule: 3

Page: 1

SIoux LOOKOUT HYDRO INC.

MAP OF DISTRIBUTION SYSTEM

SIoux LOOKOUT HYDRO INC.

SAM LAKE DS - owned by Hydro One

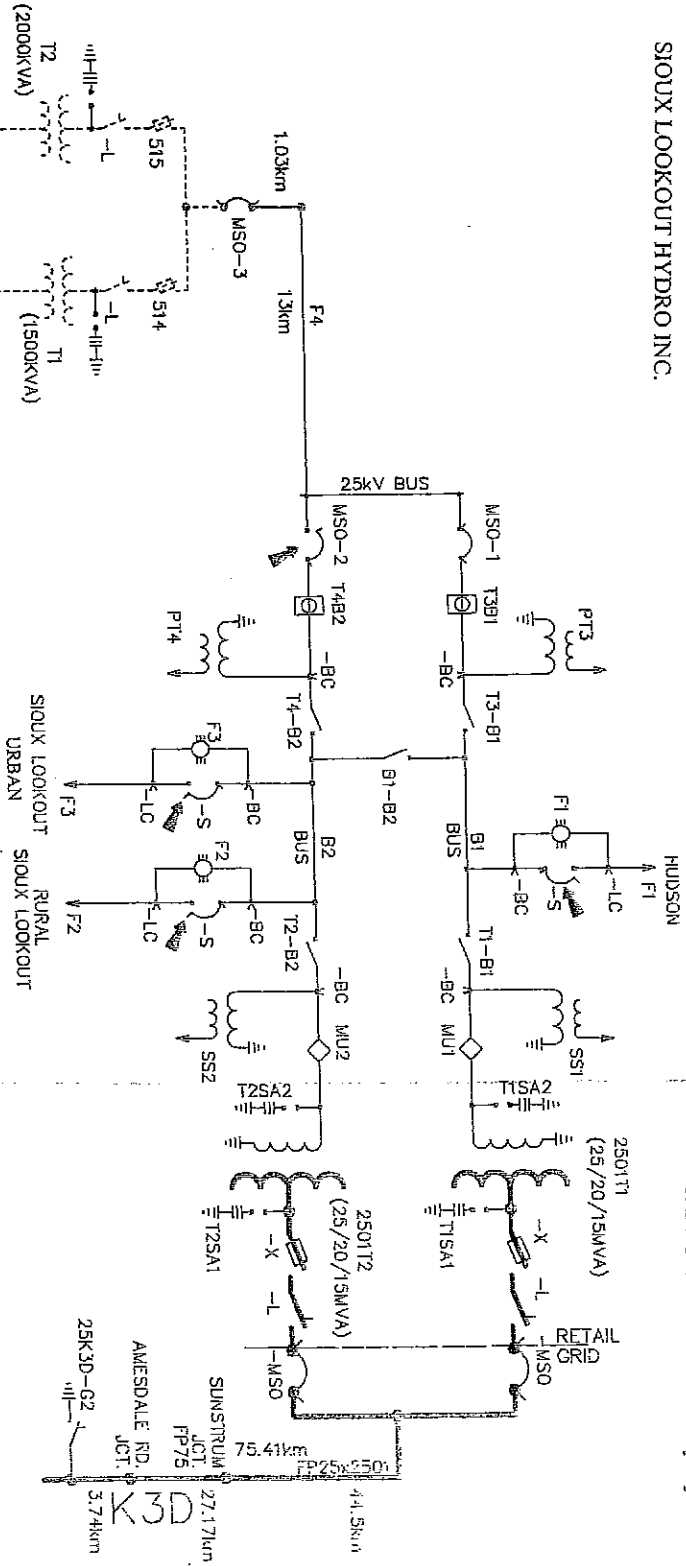

MACKENZIE FOREST
PRODUCTS INC.

31K3D-
10MSO P.432
15K3D-

TO

44.5km
27.17km
3.74km
K3D

SIoux LOOKOUT HYDRO INC.

UTILITY ORGANIZATIONAL CHART

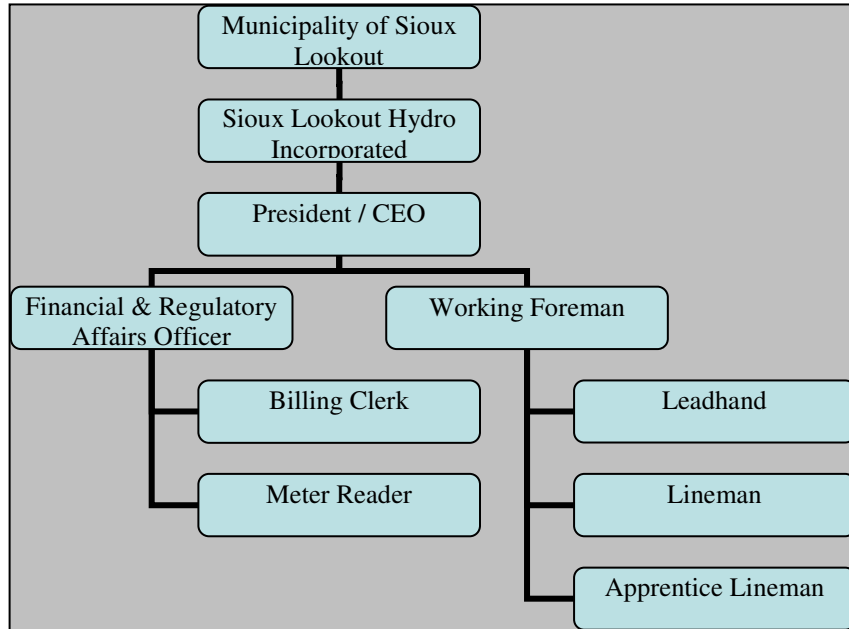

SIoux LOOKOUT HYDRO INC.

CORPORATE ENTITIES RELATIONSHIP CHARTS

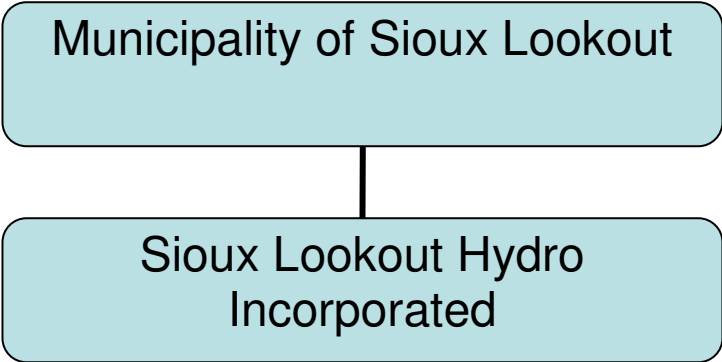

SIoux LOOKOUT HYDRO INC.

PLANNED CHANGES IN CORPORATE AND OPERATIONAL STRUCTURE

As at the date of this application, SLHI does not plan to make any changes to its Corporate and Operational Structure.

SIoux LOOKOUT HYDRO INC.

APPENDIX A

CONDITIONS

OF

SERVICE

APRIL 30, 2003

Amended June 5, 2007

SIoux LOOKOUT HYDRO INC.

**APPENDIX A –
CONDITIONS OF SERVICE**

Table of Contents

SECTION 1 INTRODUCTION

- 1.1. Identification of Distributor and Service Area
- 1.2. Related Codes, and Governing Laws
- 1.3. Interpretation
- 1.4. Amendments and Changes
- 1.5. Contact Information
- 1.6. Customer Rights
- 1.7. Distributor Rights
- 1.8. Disputes

SECTION 2 DISTRIBUTION ACTIVITIES (GENERAL)

- 2.1 Connections
 - 2.1.1 Building that Lies Along
 - 2.1.2 Expansions / Offer to Connect
 - 2.1.3 Connection Denial
 - 2.1.4 Inspections Before Connection
 - 2.1.5 Relocation of Plant
 - 2.1.6 Easements
 - 2.1.7 Contracts
- 2.2 Disconnection
- 2.3 Conveyance of Electricity
 - 2.3.1 Limitations on the Guaranty of Supply
 - 2.3.2 Power Quality
 - 2.3.3 Electrical Disturbances
 - 2.3.4 Standard Voltage Offerings
 - 2.3.5 Voltage Guidelines
 - 2.3.6 Back-up Generators
 - 2.3.7 Metering
- 2.4 Tariffs and Charges
 - 2.4.1 Service Connections
 - 2.4.2 Energy Supply
 - 2.4.3 Deposits
 - 2.4.4 Billing
 - 2.4.5 Payments & Late Payment Charges

SIOUX LOOKOUT HYDRO INC.

2.5 Customer Information

Table of Contents (continued)

SECTION 3 CUSTOMER SPECIFIC

- 3.1 Residential
- 3.2 General Service (Below 50 kW)
- 3.3 General Service (Above 50 kW)
- 3.4 General Service (Above 1000 kW)
- 3.5 Embedded Generation
- 3.6 Embedded Market Participant
- 3.7 Embedded Distributor
- 3.8 Unmetered Connections
 - 3.8.1 Street Lighting
 - 3.8.2 Traffic Signals & X-Walks
 - 3.8.3 Miscellaneous Unmetered Loads
 - 3.8.4 Decorative Lighting and Tree Lighting Services

SECTION 4 GLOSSARY OF TERMS

SECTION 5 APPENDICES

SIoux LOOKOUT HYDRO INC.

SECTION 1 INTRODUCTION

1.1 Identification of Distribution and Territory

In these Conditions of Service, “Hydro” refers to Sioux Lookout Hydro Inc. The service area of Hydro coincides with The Municipality of Sioux Lookout geographical boundaries as at January 1, 1998.

1.2 Related Codes and Governing Laws

1. Electricity Act, 1998
2. Ontario Energy Board Act, 1998
3. Distribution License
4. Affiliate Relationships Code
5. Transmission System Code
6. Distribution System Code
7. Retail Settlement Code
8. Standard Service Supply Code

1.3 Interpretations

Words referring to a gender include any gender.

Words referring to the singular include the plural and vice versa.

1.4 Amendments and Changes

The provisions of this Conditions of Service and any amendments made from time to time form part of any Contract made between Hydro and any connected Customer, Retailer, or Generator, and this Conditions of Service supersedes all previous Conditions of Service, oral or written, of **Sioux Lookout Hydro Inc.** as of its effective date.

1.5 Contact Information

SIoux LOOKOUT HYDRO INC.

Sioux Lookout Hydro after hours number for customers 737-3806

Sioux Lookout Hydro Business Hours 8:00 AM – 4:30 PM CST 737-3800

OFFICE STAFF

Gord Maki – **President/CEO** 737-2215
Cell 737-0442

Deanne Kulchyski 737-4825
Cell 737-9218

Tracey Ellek 737-3050

LINEMEN

Tom Sayers (Leadhand) 737-2423
Cell 737-9609

Tony George 737-2849

Sheldon Hackl 737-7749

Lineman on call 737-0443

1.6 Customer Rights

Hydro shall only be liable to a Customer and a Customer shall only be liable to Hydro for any damages that arise directly out of the wilful misconduct or negligence:

- Of Hydro in providing distribution services to the Customer;
- Of the Customer in being connected to Hydro's distribution system; or
- Of Hydro or Customer in meeting their respective obligations under these conditions, their licences and any other applicable law.

Notwithstanding the above, neither Hydro nor the Customer shall be liable under any circumstances whatsoever for any loss of profits or revenues, business interruption losses, loss of contract or loss of goodwill, or for any indirect, consequential, incidental or special damages, including but not limited to punitive or exemplary damages, whether any of the said liability, loss or damages arise in contract, tort or otherwise.

1.7 Distributor Rights

SIoux LOOKOUT HYDRO INC.

1.7.1 Access to Customer Property

Hydro shall have access to Customer property in accordance with *Section 40 of the Electricity Act, 1998*.

1.7.2 Safety of Equipment

The Customer will comply with all aspects of the Ontario Electrical Safety Code with respect to insuring that equipment is properly identified and connected for metering and operating purposes. The Customer will take whatever steps necessary to correct any deficiencies, in particular cross wiring situations, within **72 Hours** of written notice by Hydro to the Customer.

If the Customer does not take such action within this time frame, Hydro shall disconnect the supply of power to the Customer. The policies and procedures of Hydro with respect to the disconnection process are further described in these Conditions of Service.

The Customer shall not build, plant or maintain trees, shrubs, landscaping or structures etc. that, in the sole opinion of Hydro, may affect the safety, reliability, or efficiency of Hydro facilities.

The Customer shall not access, use or interfere with the distribution facilities of Hydro except in accordance with a written agreement. The Customer must also grant the right to sea, secure and/or prevent from tampering any point where a connection may be made on the line side of metering equipment.

1.7.3 Operating Control

The Customer will provide a convenient and safe place, satisfactory to Hydro for installing, maintaining and operating its equipment in, on, or about the Customer's premises. Hydro assumes no risk and will not be liable for damages resulting from the presence of its equipment on the Customer's premises or approaches thereto, or action, omission or occurrence beyond its control, or negligence of any persons over whom Hydro has no control.

No person shall remove, replace, alter, repair, inspect or tamper with equipment of Hydro except an employee or agent of Hydro or another person lawfully entitled to do so.

Customers will be required to pay the cost of repairs or replacement of Hydro equipment that has been damaged or lost by the direct or indirect act or omission of the Customer or its agents.

1.7.4 Repairs of Defective Customer Electrical Equipment

The Customer will be required to repair or replace any equipment owned by the Customer that may, in the sole opinion of Hydro, affect the integrity or reliability of the Hydro distribution system. If the Customer does not take such action within **72 hours** of written notice, Hydro shall disconnect the supply of power.

SIoux LOOKOUT HYDRO INC.

Policies and procedures with respect to the disconnection process are further described in **Section 2.2** of these Conditions of Service.

1.7.5 Repairs of Customer's Physical Structures

The physical location on a Customer's premises at which a Distributor's responsibility for operational control of distribution equipment ends is defined by the OEB's Distribution System Code as the "Operational Demarcation Point".

Depending on the Operational Demarcation Point, construction and maintenance of all civil works on private property owned by the Customer, including such items as transformer vaults, transformer rooms, transformer pads, cable chambers, cable pull rooms and underground conduit, will be the responsibility of the Customer. All civil work on private property must be inspected and accepted by Hydro and the Electrical Safety Authority. The Customer is responsible for the maintenance and safe keeping conditions of its electrical, structural and mechanical facilities located on private property.

1.8 Disputes

To resolve disputes, Hydro will follow the terms of Section 23 of the Transitional Distribution Licence. *Section 23 of the Transitional Distribution Licence states:*

The Licensee shall:

- a) Establish proper administrative procedures for resolving complaints by Consumers and other market participants' complaints regarding services provided under the terms of this Licence.
- b) Publish information, which will facilitate its Customers accessing its complaints resolution process.
- c) Refer unresolved complaints and subscribe to an independent third party complaints resolution agency, which has been approved by the Board.
- d) Make a copy of the complaints resolution procedure available for inspection by members of the public at each of the Licensee's premises during normal business hours.
- e) Give or send free of charge a copy of the procedure to any person who reasonably requests it; and
- f) Keep a record of all complaints whether resolved or not including the name of the complainant, the nature of the complaint, the date resolved or referred and the result of the dispute resolution.

Hydro's complaints resolution procedure is as follows:

For power outages, or issues related to power supply and delivery, you should contact Sioux Lookout Hydro Inc. at (807) 737-3800 during normal business hours and at (807) 737-3806 after normal business hours. For complaints related to you electricity contract with a retailer, we suggest that you start by contacting you retailer's Customer Service Department. Keep notes of your actions, including the names of

SIoux LOOKOUT HYDRO INC.

the company representatives you talk to. Follow up with a letter if you don't get satisfaction. If the problem cannot be resolved, you should call the Ontario Energy Board at 1-877-632-2727.

SECTION 2 DISTRIBUTION ACTIVITIES (GENERAL)

2.1 Connections

2.1.1 Building that Lies Along

1. For the purpose of these Conditions, "Lies along" means a Customer property or parcel of land that is directly adjacent to, or abuts onto the public road allowance where Hydro has distribution facilities of the appropriate voltage and capacity; and:
 - i. The building can be connected to Hydro's Distribution system without an Expansion or Enhancement and;
 - ii. The service installation meets the conditions listed in the Conditions of Service of the Hydro that owns and operates the distribution line.
2. System connections will incur a variable connection charge only. Capital Contribution Charges and Basic Connection charges do not apply.

The basic connection for each Customer shall include:

- iii. Supply and installation of overhead distribution transformation capacity or an equivalent credit for transformation equipment and;
- iv. Up to 30 metres of overhead conductor.

2.1.2 Expansions / Offer to Connect

Hydro will offer to connect on a cost recovery basis. Contact the Engineering Department six months in advance.

2.1.3 Connection Denial

The Distribution System Code provides for the ability of Hydro as a Distributor to deny connections. As a Distributor, Hydro is not obligated to connect a building within its service area if the connection would result in any of the following:

- Contravention of existing laws of Canada and the Province of Ontario.
- Violations of conditions in Hydro's Licence.

SIoux LOOKOUT HYDRO INC.

- Use of a distribution system line for a purpose that it does not serve and that the Distributor does not intend to serve.
- Adverse affect on the reliability or safety of the distribution system.
- Public safety reasons or imposition of an unsafe work situation beyond normal risks inherent in the operation of the distribution system.
- A material decrease in the efficiency of the distributor's distribution system.
- A materially adverse effect on the quality of distribution services received by an existing connection.
- Discriminatory access to distribution services.
- If the person requesting the connection owes Hydro money.
- If an electrical connection to Hydro's distribution system does not meet Hydro's design requirements.
- Any other conditions documented in Hydro's Condition of Service Document.

If Hydro refuses to connect a building in its service area that lies along one of its distribution lines, Hydro shall inform the person requesting the connection of the reasons for the denial, and where Hydro is able to provide a remedy, make an offer to connect. If Hydro is not capable of resolving the issue, it is the responsibility of the Customer to do so before a connection can be made.

2.1.4 Inspections Before Connections

All new, altered, or enlarged electrical installations, or any installations disconnected for more than three months must be installed according to the Electrical Safety Code. Hydro is prohibited by law from supplying power to, or energizing in any way, installations that have not been inspected and approved by the Electrical Safety Authority (ESA).

All connections, disconnections and reconnections on the Hydro side of the service must be performed by employees of Hydro and shall be arranged in advance by the Customer.

If in the opinion of Hydro, unsafe conditions exist on a Customer's property, Hydro may apply to the Electrical Safety Authority (ESA) to inspect the conditions.

All underground electrical services installed or altered on public and private property between the Hydro Main Lines and the Customer's Delivery Points are subject to inspection by Hydro at the Customer's expense.

2.1.5 Relocation of Plant

If the Customer requests an established underground or overhead service to be relocated for any reason, the Customer will bear the full cost of relocation of the service.

2.1.6 Easements

SIOUX LOOKOUT HYDRO INC.

The Customer shall grant, at no cost to Hydro, where required, an easement to permit installation and maintenance of service. The width and extent of this easement is to be determined by Hydro.

2.1.7 Contracts

All Customers must sign a Contract prior to connection of electrical service. If for some reason , a Contract has not been signed, the Customer is still bound to the terms and conditions as specified in the Contract.

Hydro requires a minimum of forty-eight hours notification for service connection.

A Contract to supply electricity is non-transferable.

A Customer shall remain liable to the utility until such time as the Contract is terminated.

2.2 Disconnection

If the supply of electricity to Hydro is interrupted or reduced as a result of an emergency or a breakdown, repair or extension of a transmission or distribution system Hydro may allocate the available electricity among the consumers in its service area.

Hydro may shut off the distribution of electricity to a property if any amount payable by a person for the distribution or retail of electricity to the property is overdue. The Customer will be sent a reminder letter three business days after the due date and a cut-off letter five business days after the reminder letter. If the account still has not been paid, Hydro will make every attempt to contact the Customer in order for them to pay their account or set up a payment schedule. If the Customer cannot be contacted or fails to meet their payment schedule obligations they will be disconnected.

Hydro may recover all amounts payable despite shutting off the distribution of electricity. Hydro may disconnect without notice in accordance with a court order or for emergency, safety or system reliability reasons.

2.3 Conveyance of Electricity

Customers requiring a three-phase supply should install protective apparatus to avoid damage to their equipment that may be caused by power interruptions of one phase, or non-simultaneous switching of phases of the Hydro.

2.3.1 Limitations on the Guaranty of Supply

Hydro agrees to use reasonable diligence to provide a regular and uninterrupted service but does not guarantee constant voltage or service and will not be liable for damages occasioned by the failure to provide such services to the Customer.

SIoux LOOKOUT HYDRO INC.

Customers requiring a higher degree of security than that of normal supply are responsible for providing standby or backup facilities to meet their security requirements at their own cost.

Hydro may at reasonable times, enter land on which its transmission or distribution system is located:

- a) To inspect, maintain, repair, alter, remove, replace or disconnect wires or other facilities used to transmit or distribute electricity; or
- b) To install, inspect, read, calibrate, maintain, repair, alter, remove or replace a meter.

2.3.2 Power Quality

Hydro attempts to maintain voltage variation limits, under normal operating conditions at the Customer's delivery points, as specified by the Canadian Standards Association C235, latest edition.

2.3.3 Electrical Disturbances

No electrical equipment shall be connected to the Customer's service that will produce an undesirable effect that may reflect in Hydro circuits.

Customers shall consult with the engineering department of Hydro in the early planning stages to ensure that proposed equipment will not cause undesirable system disturbances.

If, in the opinion of the Hydro, an undesirable system disturbance is being caused by existing Customer equipment, the Customer will be required to cease operation of the equipment until remedial action has been taken. If the Customer does not take such action within a reasonable time, Hydro may disconnect the supply of power to the Customer.

Hydro at its discretion, may require the installation of additional facilities to nullify any undesirable effect in Hydro's circuits, and the additional facilities will be installed at the Customer's expense.

2.3.4 Standard Voltage Offerings

DISTRIBUTION

VOLTAGE: 14400/25000V

STANDARD

SECONDARY: where Hydro retains ownership of transformers, the secondary Voltage supplied to the Customer shall be one of the following:
120/240V, 1 Phase, 3-Wire or
120/208V, 3 Phase, 4-Wire or
347/600V, 3 Phase, 4-Wire

SIoux LOOKOUT HYDRO INC.

2.3.5 Voltage Guidelines

Hydro attempts to maintain voltage variation limits, under normal operating condition at the Customer's delivery points, as specified by the Canadian Standards Association C235, latest edition.

2.3.6 Back-up Generators

Customers with portable or permanently connected generation capability used for back up shall comply with all applicable criteria of the Ontario Electrical Safety Code. In particular, the Customer shall ensure that Customer's back-up generation does not parallel with the Hydro system without a proper interface protection and does not adversely affect Hydro's system.

Customers with permanently connected back-up generation equipment shall notify Hydro regarding the presence of such equipment.

2.3.7 Metering

2.3.7.1 General

All equipment used shall comply with *the "Electricity and Gas Inspection Act"* as stated by Industry Canada, Legal Metrology.

The latest edition of rules in the *"Ontario Electrical Safety Code"* shall govern all installations.

All installations shall be further governed by the policies and engineering standards of *Hydro*.

All equipment used shall be rated and marked C.S.A. approved to the latest standards of the Canadian Standards Association.

Equipment replacement shall be carried out by the original equipment provider or, in the case of damage, by the party that caused the damage.

THE CUSTOMER

Shall not perform unauthorized work within 3m (10ft) of Hydro's primary main line.

Shall obtain a service location layout from the Hydro Engineering Department prior to any construction to avoid delay in energizing the service.

Shall notify the Engineering Department when they are ready for inspection the service trench.

SIoux LOOKOUT HYDRO INC.

Shall provide Hydro access to meters in areas that are not normally available to the general public (i.e. Keys when deemed necessary to Hydro specifications).

Shall provide a certificate of approval for connection by the Electrical Safety Authority

Shall provide a minimum of forty-eight hours notice required prior to energization.

Shall at all times provide a safe working distance of 1220m (48') around metering equipment.

Shall notify Hydro of any change that would alter the existing location, ampacity or load on the service.

Shall pay all the expense fees associated with the service in advance of any construction, the details of which may be obtained by contacting the Hydro's Engineering Department.

Shall provide individual metering for each separate store, shop, and apartment or industrial unit located in a shopping plaza or industrial unit.

HYDRO

Shall energize the primary and/or connect the secondary terminations at the transformer and install a revenue meter. Under normal circumstances the Hydro will energize the service within 48 hours upon receipt of the written service connection approval

Note: The 48 hour connection notice period is only possible for energizing equipment previously installed in anticipation of the service being energized. **To ensure that the equipment installation meets with Hydro requirements, the Customer must notify the Engineering Department well in advance of the 48-hour connection notice period.**

Shall inspect the Customer's underground service trench between the Main line and the service entrance point prior to back filling of the trench.

Shall retain the right to refuse connecting a service.

SINGLE PHASE METERING: Residential and small commercial

All services will be supplied at 120/240 volts, single phase 3-wire.

All new services shall be preferred underground and will be designed to 200 amps minimum.

All meter bases shall be for socket type meters and of the manufacturer's designation for over sized model" as apposed to their "standard size model".

SIoux LOOKOUT HYDRO INC.

THE CUSTOMER:

Shall supply a 200-amp meter base as per Table "A" except in a 400 amp service where a 400-amp combination or C>M>S> meter base is required.

Shall supply and install the meter base, before the main disconnect, at 1.67m. +/-150mm (5ft..6in. +/-6in) from the finished grade to the centre of the meter, within 2.0m (5ft) from the corner of the building closest to the distribution line.

THREE PHASE METERING: Larger commercial operations.

Authorization to install a service other than stated below must be obtained from the Engineering Department. All new and upgraded services will be supplied with a utilization voltage of 120/208 or 347/600, 3 phase and 4-wire.

Specialty metering items or conditions (other than the Hydro's normal) will be supplied by the Customer (i.e.: Electronic Pulse Metering, Primary Metering etc.)

THREE PHASE METERING:

All cabinets shall be 1220 x 1220 x 300mm (48"x48"x12") unless stated otherwise.

Where services utilize instrument transformers mounted in the switchgear an 820 x 820 x 30mm (32"x32"x12"), the cabinet shall be installed within 9 metres (30') of the instrument transformers There shall be a 38mm (1.5") conduit between the instrument transformer cabinet and the meter cabinet.

The meter cabinet shall be complete with a 120-volt outlet fed from a dedicated, 15 amp, Ground Fault Interrupt, circuit breaker and a dedicated "voice" quality or better telephone line. The telephone line shall be activated at Hydro's discretion and at the Customer's expense.

The Customer shall supply the back plate to Hydro, a minimum of two weeks prior to the required installation date. The following information shall be marked in indelible ink on the back plate:

- Top of the back plate marked "TOP" (since the backing plate mounting may not be square).
- Location where "LINE" and "LOAD" wires will enter and exit at opposite ends of the cabinet.
- Contact person/telephone numbers for the Company, Customer, and electrical contractor. Service voltage and amperage size. Number and size of service conductors.

Leave 1.83m (6ft.) of service conductor looped in the cabinet for meter connections.

SIoux LOOKOUT HYDRO INC.

Where more than one conductor per phase is used, the connectors shall be provided by the Customer and charged to the Customer.

The Customer shall supply equipment and labour except for the meters, instrument transformers and labour for the meter connections in a meter cabinet.

All existing overhead services being upgraded may remain overhead at the discretion of Hydro.

THE CUSTOMER:

Services up to 200 amps shall use a 7-jaw, socket type meter base for a self-contained meter and be of the manufacturer's "over sized model" as opposed to their "standard size model" (refer to Table "A")

Services above 200 amps require a meter cabinet inside the building. Main switch to be installed ahead of the meter on all three phase services.

2.3.7.2 Current Transformer Boxes

Hydro will supply an outdoor meter cabinet at the customers cost.

2.3.7.3 Interval Metering

Hydro will supply interval metering for customers over 1000kW with communication.

Hydro will supply interval metering for less than 1000kW at a cost to the customer. The customer will supply communication.

2.3.7.4 Meter Reading

Meters will be read on a monthly basis for all customer classes. If a reading cannot be obtained, the meter reader will leave a card to be filled out and returned to Hydro by the Customer. If the card has not been returned by the date the bill is to go out, an estimate will be made by Hydro. The estimate will be based on the Customer's past consumption history.

2.3.7.5 Final Meter Reading

Customers must notify Hydro at least **48 hours** in advance to schedule a final meter reading at which time a work order will be filled out. The final meter reading will be done in the morning on the date it was scheduled.

SIoux LOOKOUT HYDRO INC.

2.3.7.6 *Faulty Registration of Meters*

The Customer will be responsible for meter designation for multi-unit accounts. Any errors will be the responsibility of the Customer.

2.3.7.7 *Meter Dispute Testing*

The Customer will be responsible for all costs associated with testing if the meter proves to be correct. Hydro will be responsible for costs if there is more than a 20% error.

2.4 Tariffs and Charges

2.4.1 Service Connection

Charges for distribution services are set out in the Schedule of Electricity Rates available from Hydro. In the event that the Ontario Energy Board approves rate changes, notice will be given by newspaper advertisements and a Customer-billing insert with the first bill of the approved rates.

2.4.1.1 Customers Switching to Retailer

There are no physical service connection differences between Standard Service Supply (SSS) Customers and retailer Customers. Both Customer energy supplies are delivered through Hydro with the same distribution requirements. Therefore, all service connections requirements applicable to SSS Customers are applicable to retailer Customers.

Where a Customer proposes the development of premises that require Hydro to place orders for equipment and before such equipment is ordered, the Customer is required to sign the necessary Supply agreement and furnish a suitable deposit.

An irrevocable letter of credit or a letter of guarantee from a chartered bank, trust company or credit union is acceptable in lieu of a cash deposit.

2.4.2 Energy Supply

2.4.2.1 Standard Supply Service

All existing Hydro Customers are automatically Standard Service Supply (SSS) Customers until such time that Hydro is informed of their switch to an electricity retailer. The Customer or Customer's authorized retailer must make the Service Transfer Request. (STR)

2.4.2.2 Retailer Supply

SIoux LOOKOUT HYDRO INC.

Standard Supply Service Customer's switching to a retailer will comply with the Service Transfer Request (STR) requirements as outlined in sections 10.5 to 10.5.6 of the Retail Settlement Code.

All requests shall be submitted through the retailers Hub provider as Electronic Business Transactions (EBT). Service Transaction Requests (STR) shall contain the information as set out in Section 10.3 of the Retail Settlement Code.

If the information is incomplete, Hydro will reject the Service Transaction Request (STR) with appropriate information of the nature of the rejection.

2.4.3 Deposits

Except for Customers who meet the deposit waiver conditions described below, all Customers are required to pay a security deposit or provide a guarantee to Hydro for all amounts owing.

All applicants for electrical service will complete a Customer Information Form (or one will be completed on their behalf with their consent) for the purpose of collecting information.

Based on this information, Sioux Lookout Hydro will request an account Security Deposit from all applicants who are unable to demonstrate a satisfactory payment record.

Security deposits for Residential customers must be made in the form of cash, cheque, Visa or Mastercard

Security deposits for General Service customers must be made in the form of cash, cheque, Visa, Mastercard or irrevocable letter of credit from a bank as defined in the Bank Act, 1991, c.46 at the discretion of the customer.

The Security Deposit must be received by Sioux Lookout Hydro no more than ten (10) working days after the deposit has been requested from the Customer in order to ensure electrical service is provided.

A satisfactory payment record will be assessed in the following sequence and exist when:

- The Customer does not owe arrears on any other Sioux Lookout Hydro account, past or present, AND,
- The Customer having been served by Sioux Lookout Hydro during the time period set out below, has no more than one (1) N.S.F. cheque, no disconnection/collection charges, no more than one disconnection notice in the last twelve (12) month period of service, OR,
- The Customer, having been served by another Utility during the time period set out below has no more than one (1) N.S.F. cheque, no disconnection/collection charges and no more than one disconnection notice in the last twelve (12) month period of service.

SIoux LOOKOUT HYDRO INC.

Subsequent to review, Security Deposits (plus applicable interest) shall be credited to the service account if a satisfactory payment record is demonstrated:

- Over twelve (12) consecutive months for Residential Service accounts
- Over sixty (60) consecutive months for General Service accounts <50kw
- Over eighty-four (84) consecutive months for General Service accounts >50kw.

Refund of a Security Deposit, plus applicable interest, will occur when an account is terminated. However, if the customer will not have a new account with Sioux Lookout Hydro, the deposit may be applied to the final bill or refunded as required. The Security Deposit is not to be applied to active account arrears.

Where a Customer's service has been disconnected for non-payment, and no security deposit is being held, Sioux Lookout Hydro may request a Security Deposit from the Customer prior to restoring service.

Interest earned on a Customer's cash Security Deposit, will be credited to the service account annually. The rate of interest will be determined by the Prime Business Rate less 2%, reviewed quarterly.

Administrative Discretion

In cases where a Security Deposit is required, and the Personal Liability Customer demonstrates financial hardship caused by this requirement, to the extent that the Customer may not be able to meet the security requirements to obtain electrical service, administrative discretion may be applied in the following manner:

- The full deposit amount may be paid in equal instalments over no more than 4 months.

Security Deposit amounts will be based on the following schedule:

RESIDENTIAL SERVICE

Single Family - All heat sources	\$250.00 Minimum**
Apartments - All heat sources	\$200.00 Minimum**

GENERAL SERVICE

A minimum of \$100.00 **

NOTES

SIOUX LOOKOUT HYDRO INC.

Single Family - Includes Townhouses
Apartments - Includes Condominiums

** The maximum amount of a security deposit shall be calculated at 2.5 times the customers average bill(over the most recent 12 consecutive months within the past 2 years). Where usage information is not available for the customer for 12 consecutive months within the past two years the customer's average monthly load shall be based on a reasonable estimate made by Sioux Lookout Hydro Inc.

2.4.4 Billing

Hydro will render bills to its Customers on a monthly basis. Bills for the use of electrical energy may be based on either a metered rate or a flat rate, as determined by Hydro.

Hydro will bill Standard Supply Service Customers.

Standard Supply Customers may dispute the charges shown on their bill by contacting and advising the Customer Care Department of Hydro.

Retailer Customers may be billed by Hydro depending on the billing options selected by the retailer in accordance with the Retail Settlement Code.

Retailer Customers may dispute the charges shown on their bill by contacting and advising the Customer Care Department of the Customer's Retailer.

2.4.5 Payment and Late Payment Charges

Bills are forwarded for energy services provided to the Customer. Bills are payable in full by the due date, otherwise a late payment charge will apply. Where the Customer on or before the due date has made a partial payment, the late payment charge will apply only to the amount of the bill outstanding at the due date. In the event of partial payment by a Customer, payments shall be allocated by the portions of the bill covering competitive and non-competitive costs.

Outstanding bills are subject to the collection process and may ultimately lead to the service being discontinued. Service will be restored once satisfactory payment has been made. Discontinuance of service does not relieve the Customer of the liability for arrears. Hydro shall not be liable for any damage on the Customer's premises resulting from such discontinuance of service. A reconnection charge will apply where the service has been disconnected due to non-payment.

SIoux LOOKOUT HYDRO INC.

The Customer will be required to pay additional charges for the processing of non-sufficient fund (NSF) cheques.

Customers will pay special charges and deposits, on request, which may arise from a variety of conditions such as:

Security Deposit:

As a guarantee of payment of energy bills some Customers will be required to pay a deposit to Hydro.

Set Up Fee:

A Set Up Fee will apply to all accounts taken over by a new customer.

2.5 CUSTOMER INFORMATION

Historical usage information will be provided to a third party who is not a retailer with the written authorization of the Customer.

Hydro may provide information for operational purposes, aggregated sufficiently such that an individual's Consumer information cannot reasonably be identified, at no charge to another distributor, a transmitter, the IMO or the OEB. Hydro may charge an OEB approved fee for all other requests for aggregated information.

At the request of a Consumer, Hydro will provide a list of retailers who have Service Agreements in effect within its distribution service area. The list will inform the Consumer that an alternative retailer does not have to be chosen in order to ensure that the Consumer receives electricity and the terms of service that are available under Standard Supply Service.

Upon receiving an inquiry from a Consumer connected to its distribution system, Hydro will either respond to the inquiry if it deals with its own distribution services or provide the Consumer with contact information for the entity responsible for the item of inquiry, in accordance with Chapter 7 of the Retail Settlement Code.

SIoux LOOKOUT HYDRO INC.

SECTION 3 CUSTOMER CLASS SPECIFIC

3.1 Residential

This section refers to the supply of electrical power to all detached, semi-detached and duplex dwelling units.

The Customer will be required to obtain an approved service layout from the Engineering Department before proceeding with the relocation or installation of any service. Failure to do so may result in the service having to be relocated at the Customer's expense.

Approved service locations or layouts are final. Any deviation without prior consultation with the Engineering Department may be subject to correction at the expense of the Customer.

No layout approvals will be done on Secondary services that are not directly attached to the Hydro's street circuits. **Electrical Safety Authority inspection is required for all work.**

The Customer will be supplied at one service entrance only. Where single-phase power is required, it will be supplied as a 3-wire service having a nominal voltage of 120/240V.

The maximum transformation on any single-phase service is 100KVA and the maximum allowable service is 400A.

No work will proceed or materials ordered until appropriate construction charges, deposits, documentations or contracts have been received. **The Electrical Safety Authority (ESA) will govern any electrical service requirement not mentioned in this section on Residential Services.**

3.1.1 OVERHEAD SERVICES FOR RESIDENTIAL CUSTOMERS:

New overhead services will only be allowed with special permission from Hydro.

All overhead services will have a minimum rating of 100A up to and including the meter base.

The Customer shall provide entrance equipment including provisions for the attachment of the supply conductors. The Ontario Electrical Safety Code will govern rules and regulations concerning masts.

Services located further than 30m (100ft.) from the Hydro's overhead street circuit may require that Customer to construct a secondary pole line. This secondary pole line will be at the Customer's expense and subject to inspection by the Electrical Safety Authority (ESA).

SIoux LOOKOUT HYDRO INC.

Where Hydro deems an overhead primary pole line to be practical, the Customer shall install and maintain such a pole line in accordance to the Electrical Safety Code.

This primary pole line shall be guyed at opposite ends in such a manner to be considered self-supporting.

The first service pole or first point of support shall be doubled dead-end construction, according to Hydro specifications and shall not be more than 30m (100ft.) from the main supply street circuit. To avoid conflict with guying, the neutral shall be continuous and tied in on a spool bolt or clevis.

The Customer shall leave sufficient wire coiled at the first point of support to reach the main supply street circuit with excess to accommodate proper dead-ending. Any wire too short will be replaced at the Customer's expense.

All primary pole lines will be insulated for 25 kV. All three phase primary services are to be 4-wire.

Pole class and sizes are as follows:

- Single phase transformer pole, 12.2m (40ft) Class 4
- Single or three phase pole line, 12.2m (40ft) Class 4
- Three phase transformer pole, 13.7m (45ft) Class 4

Demarcation Point.

On services within 30m (100ft) of the main road circuit that do not require a secondary pole line, Hydro will be responsible up to and including the secondary connections at the mast.

Any secondary services over 30m (100ft) where the Customer is required to provide a secondary pole line, the point of demarcation will be the connections to the overhead secondary street circuit.

Minimum Requirements

In addition to the requirements of the Ontario Electrical Safety Code (latest edition), the following conditions shall apply: A clevis type insulator is to be supplied and installed by the Customer. This point of attachment device must be located:

- a. Not less than 4.5 metres (15 feet) nor greater than 5.5 metres (18 feet) above grade (to facilitate proper ladder handling techniques).
- b. Between 150 Millimetres and 300 Millimetres (6-12 inches) below the service head.

A large, 4-jaw meter socket of an approved manufacturer shall be provided. Certain areas will require a 5-jaw socket as determined by Hydro.

3.1.2. UNDERGROUND SERVICES FOR RESIDENTIAL CUSTOMERS

All underground service wires whether supplied from Hydro's Main Line or from a private pole line, will be installed and supplied by the Customer at their expense.

SIoux LOOKOUT HYDRO INC.

The trench route must be approved by Hydro and the Customer is to follow the route indicated on the underground drawing supplied by Hydro. Any deviation from this route must be pre-approved. The Customer will be responsible for all costs associated with the design and inspection, and all additional re-design and subsequent re-inspection costs due to changes or deviations initiated by the Customer or its agents.

Where the Corporation's main line is on the opposite side of the road allowance, the Customer shall be responsible for the cost of the road crossing.

The Customer will assure the provisions for the service entrance and meter meets the approval of Hydro.

It is the responsibility of the Customer or their contractor to obtain clearances from all of the utility companies (including Hydro) before digging.

It is the responsibility of the Customer to contact Hydro to inspect each trench prior to the installation of service cables.

The Customer shall ensure that any intended tree planting has appropriate clearance from the underground electrical plant.

Due to weather conditions in our area, Hydro will not be installing underground services during the freeze-up period of November to May of the following year. For services for which the **Electrical Safety Authority** inspection has been **completed** by November 1st, Hydro will install the required underground service. We recommend that a temporary overhead service be installed during the freeze-up period, if required, at the Customer's expense and the permanent underground service be installed during the following summer.

Underground Secondary

All underground secondary services will be a minimum rating of 200 Amp, up to and including the meter base.

The Customer shall install secondary conductors in a 100 mm (4 in) PVC Type 11 duct from the main line to the delivery point according to Hydro specifications if required.

The Customer will supply all adapter, sceptre pipe, weather heads and clips required to take the secondary wires up the pole to connection point at the mainline. Hydro will supply at Customer's expense if requested.

Meter base terminations will be supplied and installed by the Customer.

SIOUX LOOKOUT HYDRO INC.

Hydro will maintain the service after energization.

Underground Primary

The Customer shall supply, install and maintain the following according to Hydro specifications:

- The transformer base complete with grounding.
- Suitable access for Hydro vehicles to the metering equipment and transformer. Where necessary this should include a suitable unobstructed paved or gravelled surface.
- Concrete encased duct bank from the transformer base to the main supply point if required.
- Primary cable will be to Hydro's specification.

Demarcation Point

The demarcation point for all secondary underground residential services supplied from the Corporation's main line, will be up to, and including the line side connection of the meter base.

Underground services which are installed or inherited by the Hydro, shall be maintained by Hydro. Site restoration by Hydro will be confined to the immediate area of the repair work and will include only the replacement of similar surface materials within the immediate area.

Sheds, patios and any type of building in the immediate area where repair work is required will be disassembled or moved by the Customer at their expense.

If the Customer damages secondary conductors owned by Hydro, the Customer will be responsible for all costs involved to execute repairs.

Where an existing service requires what is considered more than one normal repair, Hydro may require the Customer to replace the service at their expense.

The trench for all underground services is to be no less than 1m (3ft) and no more than 1.3m (4ft) in depth.

Due to secondary line losses; the maximum allowable length of secondary service (including pole riser distance will be 75 meters (250 ft) for 3/0 aluminum. For longer distances, contact the Engineering Department.

If the secondary cables are supplied from a private pole line, the termination shall be done by the Customer at their own expense. If the secondary cables are supplied from Hydro's Main line, the termination at the supply point shall be done by Hydro at the expense of the Customer.

SIoux LOOKOUT HYDRO INC.

The Customer will supply, install and maintain a rigidly mounted 50 mm (2 in) minimum dia. I.P.S., C.S.A. approved service entrance conduit, termination 600mm (2 ft) below grade complete with conduit bushing. The Customer is also responsible for all meter base connections.

3.2 General Service (Below 50 kW)

The Customer shall supply the following to Hydro well in advance of installation commencement:

- Required in-service date
- Proposed Service Entrance equipment's Rated Capacity (Amperes) and Voltage rating and metering requirements
- Proposed Total Load details in kVA and /or kW (Winter and Summer)
- Locations of other services, gas telephone, water and cable TV.
- Details respecting heating equipment, air-conditioners, motor starting current limitation and any appliances which demand a high consumption of electrical energy.
- Survey plan and site plan indicating the proposed location of the service entrance equipment with respect to public rights-of-way and lot lines.

The Customer shall construct or install all civil infrastructure (including but not limited to poles, UG conduits, transformer pad) on private property. All civil infrastructures are to be in accordance with Hydro current standards, practices, specifications and this Conditions of Service and are subject to Hydro inspection and acceptance.

It is the responsibility of the Customer and his/her contractor to obtain clearances **from all of the utility companies (including Hydro) before digging.**

In addition Hydro will carry out the necessary construction and electrical work to maintain existing supplies by providing standard overhead or underground supply services to Customers affected by Hydro construction activities. If a Customer requests special construction beyond the normal Hydro standard installation specifications, the Customer shall pay the additional cost, including engineering and administration fees.

The Customer's electrical room must be located to provide safe access from the outside or main hallway, and not from an adjoining room, so that it is readily accessible to Hydro employees and agents at all hours to permit meter reading and to maintain electric supply. This room must be locked. The Customer shall install a pad bolt with mortise. Hydro shall provide a secure arrangement so that Hydro padlock can be installed as well as the Customer's lock. The electrical room shall not be used for storage or contain equipment foreign to the electrical installation within the area designated as safe working space. All stairways leading to electrical rooms above or below grade shall have a handrail on at least one side as per the Ontario Building Code and shall be located indoors.

The electrical room shall have a minimum ceiling height of 2.2m clear, be provided with adequate lighting at the working level, in accordance with Illuminating Engineering Society (I.E.S.) standards, and a 120 V

SIoux LOOKOUT HYDRO INC.

convenience outlet. The lights and convenience outlet noted above and any required vault circuit shall be supplied from a panel located and clearly identified in the electrical room.

The Customer will be supplied via one service entrance and one service voltage only. The allowable utilization voltages are:

- 120/240 volt, 1 phase, 3-wire
- 120/208 volt, 3 phase, 4-wire
- 347/600 volt, 3 phase, 4-wire

All new services from Hydro main line will be installed below ground according to Hydro specifications, at the cost of the Customer. Any exceptions of the above will be at the discretion of Hydro.

The maximum transformation supplied by Hydro is as follows:

Primary voltage	# of Phases	Transformation
14400	1 phase	167 kVA

Underground Service Requirements

The Customer shall construct or install all civil infrastructure (including but not limited to poles, UG conduits, transformer pad) on private property that is deemed required by Hydro. All civil infrastructures are to be in accordance with Hydro current standards, practices, specifications and this Conditions of Service and are subject to Hydro inspection/acceptance. The Customer is responsible to maintain all its structural and mechanical facilities on private property in a safe condition satisfactory to Hydro.

Each trench route must be approved by Hydro. Any deviation from this route must also be approved by Hydro the Customer will be responsible for Hydro costs associated with re-design and inspection services due to changes or deviations initiated by the Customer or its agents or any other body having jurisdiction. It is the responsibility of the Customer or his/her contractor to obtain clearances from all of the utility companies (including Hydro) before digging.

It is the responsibility of the Customer to contact Hydro to inspect each trench prior to the installation of cables.

If the distance from Hydro's main line to the service entrance is more than 75m (246 ft) Hydro may require the service be designed and installed for distribution voltage.

If the Customer requests an established underground or overhead service to be relocated due to construction of a building or other reason, the Customer will bear the full cost of relocation of the service.

SIoux LOOKOUT HYDRO INC.

Underground Secondary

The Customer shall install secondary conductors in a 75mm (3 in) PVC Type II duct from the main line to the delivery point according to Hydro Inc specifications. The Customer will supply all adapters, sceptre pipe, weather-heads and clips required to take the secondary wires up the pole to the connection point at the main line.

Underground Primary

The Customer shall supply, install and maintain the following according to Hydro specifications:

- The transformer base complete with grounding.
- Suitable access for Hydro Inc vehicles to the metering equipment and transformer. Where necessary this should include a suitable unobstructed paved or gravelled surface.
- Concrete encased duct bank from the vault to the main supply point if required.

Where Hydro deems an overhead primary supply to be practical; the Customer shall install and maintain such a pole line in accordance to the Electrical Safety Code. This primary pole line shall be guyed at opposite ends in such a manner to be considered self-supporting.

The first service pole or first point of support shall be double dead-end construction according to Hydro specifications and shall not be more than 30m (98.5 ft) from the main supply street circuit. To avoid conflict with guying, the neutral shall be continuous and tied in on a spool bolt or clevis.

The Customer shall leave sufficient wire coiled at the first point of support to reach the main supply street circuit with excess to accommodate proper dead-ending. Any wire too short will be replaced at the Customer's expense.

All primary pole lines will be insulated for 25 kV. All three phase primary services are to be 4-wire.

Pole class and sizes are as follows:

- Single phase transformer pole, 12.2 m (40 ft) Class 4
- Three phase transformer pole, 13.7 (45 ft) Class 4
- Single or three phase pole line, 12.2m (40 ft) Class 4

Temporary Services (other than Residential)

A temporary service is a normally metered service provided for construction purposes or special events. Temporary services can be supplied overhead or underground. Prior to any temporary service being installed, the Customer must contact the Engineering Department to arrange for a layout of the installation. The Customer will be responsible for all associated costs for the installation and removal of equipment

SIoux LOOKOUT HYDRO INC.

required for a temporary service to Hydro point of supply. Temporary services may be provided for a period of no more than 12 months. Temporary services must be renewed thereafter if an extension is required and the equipment for such temporary service must be re-inspected at the end of the 12-month period.

Subject to the requirements of Hydro, supply will be connected after receipt of a 'Connection Authorization' from the Electrical Safety Authority, a signed contract and payment of any associated costs.

3.3 General Service (Above 50 kW)

All non-residential Customers with an average peak demand greater than 50kW over the past twelve months are to be classified as General Services above 50kW. For new Customers without prior billing history, the peak demand will be based on 90% of the proposed capacity or installed transformer.

The Customer shall supply the following to Hydro well in advance of installation commencement:

- Required in-service date
- Proposed Service Entrance equipment's Rated Capacity (Amperes) and Voltage rating and metering requirements.
- Proposed Total Load details in kVA and or kW (Winter Summer)
- Locations of other services, gas, telephone, water and cable TV.
- Details respecting heating equipment, air-conditioners, motor starting current limitation and any appliances that demand a high consumption of electrical energy.
- Survey plan and site plan indicating the proposed location of the service entrance equipment with respect to public rights-of-way and lot lines.
- For General Service Class Customers (above 50 kW demand), electrical, architectural and/or mechanical drawings are required by Hydro.

The Customer shall construct or install all civil infrastructure (including but not limited to poles, UG conduits, transformer pad) on private property. All civil infrastructures are to be in accordance with Hydro current standards, practices, specifications and this Conditions of Service and are subject to Hydro's inspection and acceptance.

It is the responsibility of the Customer or his/her contactor to obtain clearances **from all of the utility companies (including Hydro) before digging**. Hydro will undertake the necessary programs to maintain and enhance its distribution plant at its expense. In the event that services or facilities to a Customer need to be restored as a result of these construction or maintenance activities by Hydro, they will be restored to an equivalent condition.

In addition Hydro will carry out the necessary construction and electrical work to maintain existing supplies by providing standard overhead or underground supply services to Customers affected by Hydro construction activities. If a Customer requests special construction beyond the normal Hydro standard

SIoux LOOKOUT HYDRO INC.

installation specifications, the Customer shall pay the additional cost, including engineering and administration fees.

The electrical room must be located to provide safe access from the outside or main hallway, and not from an adjoining room, so that it is readily accessible to Hydro employees and agents at all hours to permit meter reading and to maintain electric supply. This room must be locked. The Customer shall install a pad bolt with mortise.

Hydro shall provide a secure arrangement so that Hydro padlock can be installed as well as the Customer's lock.

The electrical room shall not be used for storage or contain equipment foreign to the electrical installation within the area designated as safe working space.

All stairways leading to electrical rooms above or below grade shall have a handrail on at least one side as per the Ontario Building Code and shall be located indoors.

The electrical room shall have a minimum ceiling height of 2.2m clear, be provided with adequate lighting at the working level, in accordance with Illuminating Engineering Society (I.E.S.) standards, and a 120 V convenience outlet. The lights and convenience outlet noted above and any required vault circuit shall be supplied from a panel located and clearly identified in the electrical room.

The Customer will be supplied via one service entrance and one service voltage only. The allowable utilization voltages are:

- 120/240 volt, 1 phase, 3-wire
- 120/208 volt, 3 phase, 4-wire
- 347/600 volt, 3 phase, 4-wire

All new services from Hydro main line will be installed below ground according to Hydro specifications, at the cost of the Customer. Any exceptions of the above will be at the discretion of Hydro.

The maximum transformation supplied by Hydro is as follows:

Primary voltage	# of Phases	Transformation
14400	1 phase	167kVA
14400/25000	3 phase	1000kVA

Underground Service Requirements

The Customer shall construct or install all civil infrastructure (including but not limited to poles, UG conduits, transformer pad) on private property that is deemed required by Hydro. All civil infrastructures are to be in accordance with Hydro current standards, practices, specifications and this Conditions of

SIoux LOOKOUT HYDRO INC.

Service and are subject to Hydro inspection/acceptance. The Customer is responsible to maintain all its structural and mechanical facilities on private property in a safe condition satisfactory to Hydro.

Each trench route must be approved by Hydro. Any deviation from this route must also be approved by Hydro the Customer will be responsible for Hydro costs associated with re-design and inspection services due to changes or deviations initiated by the Customer or its agents or any other body having jurisdiction. It is the responsibility of the Customer or his/her contractor to obtain clearances from all of the utility companies (including Hydro) before digging.

It is the responsibility of the Customer to contact Hydro to inspect each trench prior to the installation of cables.

If the distance from Hydro's main line to the service entrance is more than 55m (246 ft) Hydro may require the service be designed and installed for distribution voltage.

If the Customer requests an established underground or overhead service to be relocated due to construction of a building or other reason, the Customer will bear the full cost of relocation of the service.

The Customer will be supplied via one service entrance and one service voltage only.

Underground Secondary

The Customer shall install secondary conductors in a 100 mm (4 in) PVC Type II duct from the main line to the delivery point according to Hydro specifications.

The Customer will supply all adapters, sceptre pipe, weather heads and clips required to take the secondary wires up the pole to the connection point at the main line.

Underground Primary

The Customer shall supply, install and maintain the following according to Hydro specifications:

- The transformer base complete with grounding.
- Suitable access for Hydro Inc vehicles to the metering equipment and transformer. Where necessary this should include a suitable unobstructed paved or gravelled surface.
- Concrete encased duct bank from the vault to the main supply point if required.
- Hydro will supply at Customer's expense.

Where Hydro deems an overhead primary supply to be practical; the Customer shall install and maintain such a pole line in accordance to the Electrical Safety Code. This primary pole line shall be guyed at opposite ends in such a manner to be considered self-supporting.

SIoux LOOKOUT HYDRO INC.

The first service pole or first point of support shall be double dead-end construction according to Hydro specifications and shall not be more than 30m (98.5 ft) from the main supply street circuit. To avoid conflict with guying, the neutral shall be continuous and tied in on a spool bolt or clevis.

The Customer shall leave sufficient wire coiled at the first point of support to reach the main supply street circuit with excess to accommodate proper dead-ending. Any wire too short will be replaced at the Customer's expense.

All primary pole lines will be insulated for 25 kV. All three phase primary services are to be 4-wire.

Pole class and sizes are as follows:

- Single phase transformer pole, 12.2 m (40 ft) Class 4
- Three phase transformer pole, 13.7 (45 ft) Class 4
- Single or three phase pole line, 12.2m (40 ft) Class 4

Temporary Services (other than Residential)

A temporary service is a normally metered service provided for construction purposes or special events. Temporary services can be supplied overhead or underground. Prior to any temporary service being installed, the Customer must contact the Engineering Department to arrange for a layout of the installation. The Customer will be responsible for all associated costs for the installation and removal of equipment required for a temporary service to Hydro point of supply. Temporary services may be provided for a period of no more than 12 months. Temporary services must be renewed thereafter if an extension is required and the equipment for such temporary service must be re-inspected at the end of the 12-month period.

Subject to the requirements of Hydro, supply will be connected after receipt of a 'Connection Authorization' from the Electrical Safety Authority, a signed contract and payment of any associated costs.

Technical Information

Where project drawings are required for approval, items under Hydro jurisdiction, the Customer or its authorized representative must ensure that the proposed drawings are in compliance with the standards of the Hydro. Approval of project drawings shall not relieve the Customer of responsibility in respect of full compliance with Hydro standards. In all cases, two copies of all relevant drawings must be submitted to Hydro. Where the Customer requires an approved copy to be returned, Three copies of all plans must be submitted.

Site & Grading Plans

SIoux LOOKOUT HYDRO INC.

All site and grading plans shall indicate the lot number, plan numbers and, when available, the street number. The site plan shall show the location of the Building on the property relative to the property lines, any driveways and parking areas and the distance to the nearest intersection. All elevations shall be shown for all structures and proposed installations.

Mechanical Servicing Plan

Mechanical Servicing Plans shall show the location of all services proposed and/or existing such as water, storm and sanitary sewers, telephone, et cetera.

Floor Plan

Floor Plans shall show the service location, other services location, driveway, parking and indicate the total gross floor area of the building.

Duct Bank Location

The Customer shall show the preferred routing of the underground duct bank on the property. This is subject to approval by Hydro.

Transformer Location

The Customer shall indicate the preferred location on the property for the high voltage transformation. This is subject to approval by Hydro. Transformation will be pad mounted depending on the project load requirements. Indicate preferred location in the building of the meter room and the main switchboard.

Single Line Diagram

The Customer shall show the main service entrance switch capacity, the required supply voltage, and the number and capacity of all sub-services showing provision for metering facilities, as well as the connected load breakdown for lighting, heating, ventilation, air conditioning et cetera. Also, indicate the estimated initial kilowatt demand and ultimate maximum demands. Provide protection equipment information where coordination is required between Hydro and Customer owned equipment.

3.4 General Service (Above 1000 kW)

All non-residential Customers with an average peak demand of 1000 kW or higher over the past twelve months are to be classified as Customers over 1000 kW. For new Customers without prior billing history, the peak demand will be based on 90% of the installed transformer.

SIOUX LOOKOUT HYDRO INC.

Where a primary service is provided to a Customer-owned substation, the Customer shall install and maintain such equipment in accordance with all applicable laws, codes, regulations, and Hydro's requirements for high voltage installations. Hydro will provide planning details upon application for service. Customer owned substations are a collection of transformers and switchgear located in a suitable room or enclosure owned and maintained by the Customer, and supplied at primary voltage: i.e. the Supply Voltage is greater than 750 volts.

Customer owned substations must be inspected by both the Electrical Safety Authority and Hydro. The Customer will provide a pre-service inspection report to Hydro. A contractor acceptable to Hydro will prepare the certified report to Hydro.

3.5 Embedded Generation

N/A

3.6 Embedded Market Participant

N/A

3.7 Embedded Distributor

N/A

3.8 Unmetered Connections

3.8.1 Street Lighting

All services supplied to street lighting equipment owned by or operated for the Municipality, the Region or the Province of Ontario shall be classified as Street Lighting Service. For rate structure details refer to Sioux Lookout Hydro Inc. Schedule of Rates. Street Lighting plant, facilities, or equipment owned by the Customer are subject to the Electrical Safety Authority (ESA) requirements and Sioux Lookout Hydro Inc. specifications.

3.8.2 Traffic Signals and Pedestrian X-Walk Signals

Traffic Signals and Pedestrian X-Walk signals shall have a rate structure equal to General Service (<50 kW) Class customers. Each Traffic Signal and Pedestrian X-Walk location is reviewed individually and is connected to Hydro low voltage distribution system. Electrical Safety Authority (ESA) "Authorization to Connect" is required prior to connecting the service.

SIoux LOOKOUT HYDRO INC.

3.8.3 Miscellaneous Unmetered Loads (<5kW)

The above service types shall have a rate structure as General Service (<50kW) Class Customers and have the same terms and conditions as outlined in the section above.

3.8.4 Decorative Lighting and Tree Lighting Services

1. Decorative or Tree Lighting if connected to the Municipal Street Lighting System will be treated as Street Lighting Class of service.
2. Decorative of Tree Lighting connected to Hydro distribution System shall have a rate structure as General Service (<50kW) Class Customers. Refer to the Schedule of Rates.
3. If the service is metered, the following outlines the Operation Demarcation point:
 - For Overhead – the top of the Customer’s service standpipe/mast.
 - For Underground – the line side of the Customer’s meter base

SIOUX LOOKOUT HYDRO INC.

SECTION 4 GLOSSARY OF TERMS

“CUSTOMER” means a person, corporation or representative of the Customer from whom the Corporation has accepted a contract;

“DELIVERY POINT” means the point at which circuits cross over from the public Right-Of-Way, or Hydro’s easements to private property;

”GENERAL SERVICE CUSTOMER” means a Customer who operates a commercial or industrial business;

“HYDRO” means Sioux Lookout Hydro Inc., or their authorized Representative;

“MAIN LINE” means Hydro Main Circuits on public Right-Of-Way or easements from which service wires are tapped;

“OPERATIONAL DEMARCATION POINT” means the physical location on a Customer’s premises at which a Distributor’s responsibility for operational control of a Distribution System ends;

“RESIDENTIAL CUSTOMER” means a Customer whose electricity requirements are for normal domestic or household purposes;

“SERVICE ENTRANCE” means the point and equipment at which the service wires enter the Customer’s premises;

“SERVICE LOCATION” means the location where the service wires enter private property. Location shall be approved by the Engineering Department, before construction;

“SERVICE WIRES” mean the conductors from the Hydro’s Main circuits on public streets or Hydro’s easements to the Customer’s premises

“EMBEDDED GENERATOR” OF “EMBEDDED GENERATION FACILITY” means a generator whose generation facility is not directly connected to the IMO-controlled grid but instead is connected to a distribution system (DSC);

“RETAILER” means a person who retails electricity;

“SUPPLY VOLTAGE” means the voltage measured at the Customer’s main service entrance equipment (typically below 750 volts). Operating conditions are defined in the Canadian Standards Association (“CSA”) Standard CAN3-C235 (latest edition);

“IMO” means the Independent Electricity Market Operator established under the Electricity Act;

SIoux LOOKOUT HYDRO INC.

“**ONTARIO ENERGY BOARD ACT**” means the Ontario Energy Board Act, 1998, S.O. 1998,C15, Schedule B;

“**DISTRIBUTION SERVICES**” means services related to the distribution of electricity and the services the Board has required distributors to carry out, for which a charge or rate has been approved by the Board under section 78 of the Ontario Energy Board Act;

“**DISTRIBUTION SYSTEM**” means a system for distributing electricity, and includes any structures, equipment or other things used for that purpose. A distribution system is comprised of the main system capable of distributing electricity to many Customers and the connection assets used to connect a Customer to the main distribution system;

“**DISTRIBUTION SYSTEM CODE**” means the code, approved by the Board, and in effect at the relevant time, which, among other things, establishes the obligations of the distributor with respect to the services and terms of service to be offered to Customers and retailers and provides minimum technical operating standards of distribution systems;

“**DISTRIBUTOR**” means a person who owns or operates a distribution system;

“**TRANSMITTER**” means a person who owns or operates a transmission system;

“**TRANSMISSION SYSTEM**” means a system for transmitting electricity, and includes any structures, equipment or other things used for that purpose

SECTION 5 APPENDICES

TABLE ‘A’

Metering Required

TYPE				
SUPPLY VOLTAGE	MAIN SWITCH AMPERES	DESCRIPTION	MAXIMUM Kva ALLOWED	
120/240	100	1-PHASE 3-WIRE	19	Manufacturer’s “Oversized Socket type meter base with 4-Jaws Manufacturer’s “Oversized” combination Socket type meter base with 5-Jaws
120/240	200	1-PHASE 3-WIRE	38	
120/240	400	1-PHASE 3-WIRE	77	

SIoux LOOKOUT HYDRO INC.

120208	200	3-PHASE 4-WIRE	58	Manufacturer's "Oversized" Combination Socket type meter base with 7-Jaws
120/208	400	3-PHASE 4-WIRE	115	Meter Cabinet 1220 x 1220 x 300 mm (48" x 48" x 12")
120/208	600	3-PHASE 4-WIRE	173	Meter Cabinet 1220 x 1220 x 300 mm (48" x 48" x 12")
120/208	800	3-PHASE 4-WIRE	231	Meter Cabinet 1220 x 1220 x 300 mm (48" x 48" x 12")
120/208*	1000	3-PHASE 4-WIRE	288	Meter Cabinet 1220 x 1220 x 300 mm (48" x 48" x 12")
347/600	400	3-PHASE 4-WIRE	166	Manufacturer's "Oversized" Socket type meter base with 7 -Jaws
347/600	400	3-PHASE 4-WIRE	333	Meter Cabinet 1220 x 1220 x 300 mm (48" x 48" x 12")
INSTRUMENT TRANSFORMERS INSTALLED IN A SWITCH GEAR CUBICLE		3-PHASE 4-WIRE	500 Kva AND OVER	Meter Cabinet 1220 x 1220 x 300 mm (48" x 48" x 12") The instrument transformer cabinet must be connected to the Meter cabinet with a 38 mm (1.5") conduit no longer that 9m (30') complete with fish rope

NOTE:

For services other than those in table 'A' the Customer must get authorization from the Engineering Department.

A switchgear manufacturer will no build the switchgear until they have the instrument transformers as specified by Sioux Lookout Hydro Inc. It is therefore essential the Customer contact the Engineering Department for co-ordination of delivering the Instrument transformers to the Manufacturer. Instrument transformers located in a 1220 x 1220 x 300 mm meter cabinet will be installed by Sioux Lookout Hydro personnel.

In all situations early contact with the Engineering Department is essential to receiving connect when desired.

TABLE B

HIGH DIRECT VOLTAGE FIELD TESTS

SYSTEM VOLTAGE	SYSTEM BIL (kV)	ACCEPTENCE TEST VOLTAGE	MAINTENANCE TEST VOLTAGE
-----------------------	------------------------	--------------------------------	---------------------------------

SIoux LOOKOUT HYDRO INC.

(kV rms) phase to phase		(kV dc)	(kV dc)
4.16 kV	45	28	23
8.32 kV	95	36	29
25 kV	170	85	68
44 kV	250	125	95

NOTES:

ACCEPTANCE TEST VOLTAGE DURATION IS NORMALLY 15 MIN. THE MAINTENANCE TEST VOLTAGE DURATION SHLL BE NOT LESS THAN 5, OR MORE THAN 15 MINUTES.

WHEN OLDER CABLES, OR OTHER EQUIPMENT SUCH AS TRANSFORMERS, SWITCHGEAR, MOTORS ETC., ARE CONNECTED TO THE CABLE TO BE TESTED, LOWER VOLTAGES THAN THOSE LISTED IN TABLE B MAY BE NECESSARY.

*MEASUREMENTS ARE IN ACCORDANCE WITH IEEE STD. 400-1991

**TABLE C
MAXIMUM LOSSES FOR DISTRIBUTION TRANSFORMERS
(CSA Standard
C802-93, clause 4.2)**

SINGLE PHASE

THREE PHASE

SIoux LOOKOUT HYDRO INC.

(Min. LV 120/240)

*

(Min. LV 208Y/120)

KVA Rating	Maximum Loss, W		KVA Rating	Maximum Loss, W	
	NL	L		NL	L
50	170	390	150	510	1300
75	210	570	225	710	2070
100	260	810	300	820	2190

**TABLE D
MAXIMUM LOSSES FOR POWER TRANSFORMERS
501 kVA – 3,000 kVA, HIGH VOLTAGE 44kV AND BELOW
(clauses 4.3.1 and 4.3.2 of C802-93)**

KVA (Min LV 600)	Imp. Range, %		Max. loss, W	
	Min.	Max	NL	L
1501-200	5	7.5	4,200	12,200
2001-2500	5	7.5	5,000	14,100
2501-3000	5	7.5	5,600	16,200

SIoux LOOKOUT HYDRO INC.

SCHEDULE 1

**Sioux Lookout Hydro Incorporated
TARIFF OF RATES AND CHARGES**

Effective May 1, 2007

EB-2007-0576

This schedule supersedes and replaces all previously approved schedules of Rates, Charges and Loss Factors

APPLICATION

- The application of these rates and charges shall be in accordance with the Licence of the Distributor and any Codes, Guidelines or Orders of the Board, and amendments thereto as approved by the Board, which may be applicable to the administration of this schedule.
- No rates and charges for the distribution of electricity and charges to meet the costs of any work or service done or furnished for the purpose of the distribution of electricity shall be made except as permitted by this schedule, unless required by the Distributor's Licence or a Code, Guideline or Order of the Board, and amendments thereto as approved by the Board, or as specified herein.
- This schedule does not contain any rates and charges relating to the electricity commodity (e.g. the Regulated Price Plan).

EFFECTIVE DATES

DISTRIBUTION RATES - May 1, 2007 for all consumption or deemed consumption services used on or after that date.

SPECIFIC SERVICE CHARGES - May 1, 2007 for all charges incurred by customers on or after that date.

LOSS FACTOR ADJUSTMENT – May 1, 2007 unless the distributor is not capable of prorating changed loss factors jointly with distribution rates. In that case, the revised loss factors will be implemented upon the first subsequent billing for each billing cycle.

SERVICE CLASSIFICATIONS

Residential

This classification applies to an account taking electricity at 750 volts or less where the electricity is used exclusively in a separate metered living accommodation. Customers shall be residing in single-dwelling units that consist of a detached house or one unit of a semi-detached, duplex, triplex or quadruplex house, with a residential zoning. Separately metered dwellings within a town house complex or apartment building also qualify as residential customers. All customers are single-phase.

General Service Less Than 50 kW

This classification applies to a non residential account taking electricity at 750 volts or less whose average monthly maximum demand is less than, or is forecast to be less than, 50 kW.

General Service 50 to 4,999 kW

This classification applies to a non residential account whose average monthly maximum demand used for billing purposes is equal to or greater than, or is forecast to be equal to or greater than, 50 kW but less than 5,000 kW. Note that for the application of the Retail Transmission Rate – Network Service Rate and the Retail Transmission Rate – Line and Transformation Connection Service Rate the following sub-classifications apply:

General Service 50 to 1,000 kW non-interval metered

General Service 50 to 1,000 kW interval metered

General Service >1,000 to 4,999 kW interval metered.

Unmetered Scattered Load

This classification applies to an account taking electricity at 750 volts or less whose average monthly maximum demand is less than, or is forecast to be less than, 50 kW and the consumption is unmetered. Such connections include cable TV power packs, bus shelters, telephone booths, traffic lights, railway crossings, etc. The level of the consumption will be agreed to by the distributor and the customer, based on detailed manufacturer information/documentation with regard to electrical consumption of the unmetered load or periodic monitoring of actual consumption.

Street Lighting

This classification applies to an account for roadway lighting with a Municipality, Regional Municipality, Ministry of Transportation and private roadway lighting, controlled by photo cells. The consumption for these customers will be based on the

SIoux LOOKOUT HYDRO INC.

calculated connected load times the required lighting times established in the approved OEB street lighting load shape template.

Page

SIoux LOOKOUT HYDRO INC.**Sioux Lookout Hydro Incorporated
TARIFF OF RATES AND CHARGES**

Effective May 1, 2007

This schedule supersedes and replaces all previously approved schedules of Rates, Charges and Loss Factors
EB-2007-0576

MONTHLY RATES AND CHARGES**Residential**

Service Charge	\$	20.30
Distribution Volumetric Rate	\$/kWh	0.0087
Regulatory Asset Recovery	\$/kWh	0.0106
Retail Transmission Rate – Network Service Rate	\$/kWh	0.0057
Retail Transmission Rate – Line and Transformation Connection Service Rate	\$/kWh	0.0050
Wholesale Market Service Rate	\$/kWh	0.0052
Rural Rate Protection Charge	\$/kWh	0.0010
Standard Supply Service – Administrative Charge (if applicable)	\$	0.25

General Service Less Than 50 kW

Service Charge	\$	36.05
Distribution Volumetric Rate	\$/kWh	0.0068
Regulatory Asset Recovery	\$/kWh	0.0104
Retail Transmission Rate – Network Service Rate	\$/kWh	0.0052
Retail Transmission Rate – Line and Transformation Connection Service Rate	\$/kWh	0.0045
Wholesale Market Service Rate	\$/kWh	0.0052
Rural Rate Protection Charge	\$/kWh	0.0010
Standard Supply Service – Administrative Charge (if applicable)	\$	0.25

General Service 50 to 4,999 kW

Service Charge	\$	414.94
Distribution Volumetric Rate	\$/kW	1.4391
Regulatory Asset Recovery	\$/kW	4.2041
Retail Transmission Rate – Network Service Rate	\$/kW	2.1218
Retail Transmission Rate – Line and Transformation Connection Service Rate	\$/kW	1.7882
Retail Transmission Rate – Network Service Rate – Interval Metered	\$/kW	2.2535
Retail Transmission Rate – Line and Transformation Connection Service Rate – Interval Metered	\$/kW	1.9603
Retail Transmission Rate – Network Service Rate – Interval Metered >1,000 kW	\$/kW	2.2508
Retail Transmission Rate – Line and Transformation Connection Service Rate – Interval Metered >1,000 kW	\$/kW	1.9763
Wholesale Market Service Rate	\$/kWh	0.0052
Rural Rate Protection Charge	\$/kWh	0.0010
Standard Supply Service – Administrative Charge (if applicable)	\$	0.25

SIoux LOOKOUT HYDRO INC.**Unmetered Scattered Load**

Service Charge (per connection)	\$	17.90
Distribution Volumetric Rate	\$/kWh	0.0068
Regulatory Asset Recovery	\$/kWh	0.0104
Retail Transmission Rate – Network Service Rate	\$/kWh	0.0052
Retail Transmission Rate – Line and Transformation Connection Service Rate	\$/kWh	0.0045
Wholesale Market Service Rate	\$/kWh	0.0052
Rural Rate Protection Charge	\$/kWh	0.0010
Standard Supply Service – Administrative Charge (if applicable)	\$	0.25

Street Lighting

Service Charge (per connection)	\$	0.87
Distribution Volumetric Rate	\$/kW	2.2980
Regulatory Asset Recovery	\$/kW	2.7359
Retail Transmission Rate – Network Service Rate	\$/kW	1.6002
Retail Transmission Rate – Line and Transformation Connection Service Rate	\$/kW	1.3824
Wholesale Market Service Rate	\$/kWh	0.0052
Rural Rate Protection Charge	\$/kWh	0.0010
Standard Supply Service – Administrative Charge (if applicable)	\$	0.25

Specific Service Charges

Customer Administration		
Statement of Account	\$	15.00
Duplicate invoices for previous billing	\$	15.00
Easement Letter	\$	15.00
Income tax letter	\$	15.00
Credit reference/credit check (plus credit agency costs)	\$	15.00
Returned cheque charge (plus bank charges)	\$	15.00
Charge to certify cheque	\$	15.00
Account set up charge/change of occupancy charge (plus credit agency costs if applicable)	\$	30.00
Meter dispute charge plus Measurement Canada fees (if meter found correct)	\$	30.00
Non-Payment of Account		
Late Payment - per month	%	1.50
Late Payment - per annum	%	19.56
Collection of account charge – no disconnection	\$	30.00
Disconnect/Reconnect Charge - At Meter During Regular Hours	\$	110.00
Disconnect/Reconnect Charge - At Meter After Regular Hours	\$	245.00
Disconnect/Reconnect at pole – during regular hours	\$	245.00
Disconnect/Reconnect at pole – after regular hours	\$	415.00
Install/Remove load control device – during regular hours	\$	110.00
Install/Remove load control device – after regular hours	\$	245.00
Temporary service – install and remove – overhead – no transformer	\$	500.00
Temporary service – install and remove – underground – no transformer	\$	300.00

SIOUX LOOKOUT HYDRO INC.

Temporary service – install and remove – overhead – with transformer	\$	1,000.00
Specific Charge for Access to the Power Poles – per pole/year	\$	22.35
Allowances		
Transformer Allowance for Ownership - per kW of billing demand/month \$/kW (0.60)		
Primary Metering Allowance for transformer losses – applied to measured demand and energy		
	%	(1.00)

LOSS FACTORS

Total Loss Factor – Secondary Metered Customer < 5,000 kW	1.0547
Total Loss Factor – Secondary Metered Customer > 5,000 kW N/A	
Total Loss Factor – Primary Metered Customer < 5,000 kW	1.0442
Total Loss Factor – Primary Metered Customer > 5,000 kW N/A	

SIoux LOOKOUT HYDRO INC.

SCHEDULE 2

**SIoux LOOKOUT HYDRO INC.
CONSTRUCTION DEVELOPMENT FEES
UNDERGROUND**

3/0	USCI Triplex Guarding	\$12.60/m \$90.00 per installation
250	MCM USCI Triplex Guarding	\$17.40/m \$145.00 per installation
1/0	25Kv Primary Underground Cable Guarding Terminations	\$13.50/m \$90.00 per circuit \$210.00 per circuit

*Fees are based on 2007 costs.

SIoux LOOKOUT HYDRO INC.

**SCHEDULE 3
SIoux LOOKOUT HYDRO INC.
CONSTRUCTION DEVELOPMENT FEES
TRANSFORMER**

TRANSFORMER PADMOUNTS – 3 PHASE

150	kVA 3 Phase 4W Transformer	\$6,700.00
	Switches and Arresters	\$1,275.00
300	kVA 3 Phase 4W Transformer	\$21,343.50
	Switches and Arresters	\$1,275.00
500	kVA 3 Phase 4W Transformer	\$12,400.00
	Switches and Arresters	\$1,275.00
750	kVA 3 Phase 4W Transformer	\$15,000.00
	Switches and Arresters	\$1,275.00
1000	kVA 3 Phase 4W Transformer	\$17,600.00
	Switches and Arresters	\$1,275.00

TRANSFORMER PADMOUNTS 1-PHASE

25	kVA Padmount 1 Phase	\$13,00.00
	Pad and Grounding	\$1,450.00
50	kVA Padmount 1 Phase	\$19,50.00
	Pad and Grounding	\$1,450.00

*Fees are based on 2007 costs

SIoux LOOKOUT HYDRO INC.

**SCHEDULE 4
SIoux LOOKOUT HYDRO INC.
CONSTRUCTION DEVELOPMENT FEES
OVERHEAD**

OVERHEAD SERVICE

#2	Triplex Beyond 30m	\$4.22/m
1/0	Triplex Beyond 30m	\$5.10/m

OVERHEAD 3 PHASE TRANSFORMER BANK

50	kVA Transformer	\$4,224.00
	Switches and Arresters	\$1,275.00

*Fees are based on 2003 costs.

SIoux LOOKOUT HYDRO INC.

PLANNED CHANGES IN CONDITIONS OF SERVICE AND SERVICE CHARGES

There are currently no changes planned for SLHI's conditions of service

SIoux LOOKOUT HYDRO INC.

LIST OF WITNESSES

A list of witnesses and their Curriculum Vitae will be provided upon request or in case of an oral hearing.

SIoux LOOKOUT HYDRO INC.

BUDGET DIRECTIVES

The Applicant compiles budget information for the three major components of the budgeting process: revenue forecasts, operating and maintenance expense forecast and capital budgets. This budget information is compiled for both the bridge and Test Years.

Revenue Forecast

The energy sales and revenue forecast model was updated to reflect more recent information. This model was then used to prepare the revenues sales and throughput volume and revenue forecast at existing rates for fiscal 2007 and 2008. The forecast is weather normalized as outlined in Exhibit 3, Tab 2, Schedule 1 and considers such factors as new customer additions and load profiles for all classes of customers.

Operating and Maintenance Expense Forecast

The operating and maintenance expenses for fiscal 2007 bridge year and the 2008 Test Year have been forecast using a zero based methodology and is strongly influenced by prior year experience. Each item is reviewed account by account for each of the forecast years.

Capital Budget

The capital budgeting process begins with a review of all the accounts.

All other capital expenditures are budgeted on a line by line basis based on need and forecasted customer growth.

SIoux LOOKOUT HYDRO INC.

CHANGES IN METHODOLOGY

SLHI' s application is consistent with pervious methodologies set out by the Board with the exception of three specific areas in which the methodology has been either introduced or revised.

1. Weather Normalized Forecast

SLHI is introducing a methodology for forecasting load and customer growth. The methodology is explained in detail in Exhibit 3, Tab 2, Schedule 1.

2. Deferral and Variance Accounts

SLHI is applying to dispose of its variance and deferral accounts. The proposed methodology is outlined at Exhibit 5, Tab 1, Schedule 4.

3. Retail Transmission Charge Adjustment

In compliance with the Board findings and Direction from the 2007 EDR's expectation that SLHI files a detailed plan proposing a remedy for its over-collection of Retail Transmission Service (RTS) charges. SLHI is proposing to apply a factor to existing RTS charges. The methodology of calculating the multiplier is illustrated at Exhibit 4, Tab 2, Schedule 11.

File Number: EB-2007-0785

Exhibit: 1

Tab: 3

Schedule: 1

Page: 1

SIoux LOOKOUT HYDRO INC.

2006 AUDITED FINANCIAL STATEMENTS

Sioux Lookout Hydro Inc.
Financial Statements
For the year ended December 31, 2006

Sioux Lookout Hydro Inc.
Financial Statements
For the year ended ended December 31, 2006

Contents

Auditors' Report	2
Financial Statements	
Balance Sheet	3
Statement of Retained Earnings	4
Statement of Operations	5
Statement of Cash Flows	6
Summary of Significant Accounting Policies	7
Notes to Financial Statements	9



BDO Dunwoody LLP
Chartered Accountants
and Advisors

37 King Street
P.O. Box 3010
Dryden Ontario Canada P8N 3G3
Telephone: (807) 223-5321
Telefax: (807) 223-2978

Auditors' Report

To the Shareholder of
Sioux Lookout Hydro Inc.

We have audited the balance sheet of Sioux Lookout Hydro Inc. as at December 31, 2006 and the statements of retained earnings, operations and cash flows for the year then ended. These financial statements are the responsibility of the company's management. Our responsibility is to express an opinion on these financial statements based on our audit.

We conducted our audit in accordance with Canadian generally accepted auditing standards. Those standards require that we plan and perform an audit to obtain reasonable assurance whether the financial statements are free of material misstatement. An audit includes examining, on a test basis, evidence supporting the amounts and disclosures in the financial statements. An audit also includes assessing the accounting principles used and significant estimates made by management, as well as evaluating the overall financial statement presentation.

In our opinion, these financial statements present fairly, in all material respects, the financial position of the company as at December 31, 2006 and the results of its operations and cash flows for the year then ended in accordance with Canadian generally accepted accounting principles.

Chartered Accountants, Licensed Public Accountants

Dryden, Ontario
March 13, 2007

**Sioux Lookout Hydro Inc.
Balance Sheet**

December 31	2006	2005
Assets		
Current		
Cash and bank	\$ 1,183,160	\$ 1,310,441
Accounts receivable	930,453	271,614
Unbilled revenue	1,103,757	1,070,610
Due from related parties (Note 2)	49,164	52,624
Inventory (Note 1)	68,617	54,038
Prepaid expenses	46,679	82,385
Taxes receivable	1,466	-
	3,383,296	2,841,712
Capital assets (Note 4)	4,704,166	4,889,766
Goodwill	300,979	300,979
	\$ 8,388,441	\$ 8,032,457
Liabilities and Shareholder's Equity		
Current		
Bank indebtedness (Note 5)	\$ 1,621,667	\$ 1,761,667
Accounts payable and accrued liabilities	1,597,680	1,155,029
Employee benefits payable (Note 6)	102,299	132,754
Taxes payable	-	3,286
Customer deposits	92,722	95,455
Due to related parties (Note 2)	423,500	286,487
	3,837,868	3,434,678
Regulatory liabilities (Note 3)	281,566	172,156
	4,119,434	3,606,834
Shareholder's equity		
Share capital (Note 8)	4,016,312	4,016,312
Retained earnings	252,695	409,311
	4,269,007	4,425,623
	\$ 8,388,441	\$ 8,032,457

The accompanying summary of significant accounting policies and notes are an integral part of these financial statements.

Sioux Lookout Hydro Inc.
Statement of Retained Earnings

For the year ended December 31	2006	2005
Retained earnings, beginning of year	\$ 409,311	\$ 482,624
Net income for the year	<u>128,542</u>	<u>59,225</u>
	537,853	541,849
Dividends	<u>(285,158)</u>	<u>(132,538)</u>
Retained earnings, end of year	<u>\$ 252,695</u>	<u>\$ 409,311</u>

**Sioux Lookout Hydro Inc.
Statement of Operations**

For the year ended December 31	2006		2005	
Revenue				
Sale of energy				
Residential and general	\$ 7,901,134	99.0 %	\$ 7,038,193	99.7 %
Street lighting	49,282	0.6 %	44,235	0.6 %
Unbilled revenue adjustment	33,146	0.4 %	(23,122)	(0.3)%
	<u>7,983,562</u>	<u>100 %</u>	<u>7,059,306</u>	<u>100 %</u>
Cost of bulk power purchased	6,616,192	82.9 %	5,779,463	81.9 %
Gross margin on energy sold	1,367,370	17.1 %	1,279,843	18.1 %
Other operating revenue (Note 10)	184,280	2.3 %	169,400	2.4 %
	<u>1,551,650</u>	<u>19.4 %</u>	<u>1,449,243</u>	<u>20.5 %</u>
Expenditures				
Administration	513,033	6.3 %	444,726	6.3 %
Amortization	234,760	2.9 %	234,042	3.3 %
Interest and bank charges	154,519	1.9 %	119,986	1.7 %
Operation maintenance	487,428	6.2 %	563,198	8.0 %
	<u>1,389,740</u>	<u>17.3 %</u>	<u>1,361,952</u>	<u>19.3 %</u>
Income before payment in lieu of taxes	161,910	2.1 %	87,291	1.2 %
Payment in lieu of taxes				
Payment in lieu of taxes	33,368	0.5 %	28,066	0.4 %
Net income for the year	\$ 128,542	1.6 %	\$ 59,225	0.8 %

The accompanying summary of significant accounting policies and notes are an integral part of these financial statements.

Sioux Lookout Hydro Inc.
Statement of Cash Flows

For the year ended December 31	2006	2005
Cash provided by (used in)		
Operating activities		
Net income for the year	\$ 128,542	\$ 59,225
Items not involving cash		
Amortization of capital assets (Note 13)	300,949	305,504
Loss on disposal of capital assets	825	965
	430,316	365,694
Changes in non-cash working capital balances		
Accounts receivable	(658,839)	370,677
Unbilled revenue	(33,147)	23,122
Due to/from related parties	140,471	34,302
Inventory	(14,579)	64,653
Prepaid expenses	35,706	(10,265)
Accounts payable and accrued liabilities	442,651	261,136
Employee benefits payable	(30,455)	26,180
Taxes payable	(4,752)	(29,751)
Customer deposits	(2,733)	26,155
	304,639	1,131,903
Investing activities		
Purchase of capital assets	(118,463)	(279,586)
Decrease in regulatory assets (liabilities)	109,410	185,112
Proceeds on sale of capital assets	2,291	3,696
	(6,762)	(90,778)
Financing activities		
Decrease in bank indebtedness	(140,000)	(140,000)
Dividends	(285,158)	(132,538)
	(425,158)	(272,538)
Increase (decrease) in cash during the year	(127,281)	768,587
Cash and bank, beginning of year	1,310,441	541,854
Cash and bank, end of year	\$ 1,183,160	\$ 1,310,441

The accompanying summary of significant accounting policies and notes are an integral part of these financial statements.

Sioux Lookout Hydro Inc. Summary of Significant Accounting Policies

December 31, 2006

Nature of Business	The company is incorporated under the laws of Ontario and is licenced by the Ontario Energy Board (OEB) as an electricity distributor.																		
Inventory	Inventory is stated at the lower of cost and net realizable value. Cost is generally determined on the average cost basis.																		
Capital Assets	<p>Capital assets are recorded at cost less accumulated amortization. Amortization is provided on a straight line basis over the assets estimated useful life.</p> <table><tr><td>Buildings</td><td>- 25</td><td>years</td></tr><tr><td>Distribution system - overhead</td><td>- 25</td><td>years</td></tr><tr><td>Distribution system - underground</td><td>- 25 and 35</td><td>years</td></tr><tr><td>Distribution transformers</td><td>- 25 and 35</td><td>years</td></tr><tr><td>Distribution meters</td><td>- 25 and 35</td><td>years</td></tr><tr><td>Other equipment - various</td><td>- from 4 to 10</td><td>years</td></tr></table>	Buildings	- 25	years	Distribution system - overhead	- 25	years	Distribution system - underground	- 25 and 35	years	Distribution transformers	- 25 and 35	years	Distribution meters	- 25 and 35	years	Other equipment - various	- from 4 to 10	years
Buildings	- 25	years																	
Distribution system - overhead	- 25	years																	
Distribution system - underground	- 25 and 35	years																	
Distribution transformers	- 25 and 35	years																	
Distribution meters	- 25 and 35	years																	
Other equipment - various	- from 4 to 10	years																	
Goodwill	Goodwill being the excess of cost over assigned values of net assets acquired, is stated at cost. No amortization is provided for goodwill. The value of goodwill is regularly evaluated by reviewing the returns of the related business, taking into account the risk associated with the investment. Any impairment in the value of the goodwill is written off against earnings.																		
Customer Deposits	Customer deposits are cash collections from customers to guarantee the payment of energy bills.																		
Revenue Recognition	<p>Revenue from the sale of electricity is recorded on a basis of cyclical billings and also includes unbilled revenue accrued in respect of electricity delivered but not yet billed.</p> <p>The amounts billed to customers for distribution services is according to rates, both fixed and by volume of power, as approved by the Ontario Energy Board.</p> <p>Pole rental revenues which is included in other operating revenue is according to rates per pole as established by the Ontario Energy Board.</p> <p>Late payment charges and interest income is recognized as revenue when earned.</p>																		

Sioux Lookout Hydro Inc. Summary of Significant Accounting Policies

December 31, 2006

Capital Contributions

Capital contributions are set up as a capital asset contra account, Contributions and Grants. This account is amortized on the same basis as the related capital assets.

Payment in Lieu of Taxes

The company accounts for payment in lieu of taxes using the tax payable method. Under this method, the company only reports as an expense the cost of current payment in lieu of taxes for the year, determined in accordance with the rules established by the taxation authorities. Future payment in lieu of taxes have not been reported as it is the opinion of management that these taxes will be recovered from customers in the future.

Use of Estimates

The preparation of financial statements in accordance with accounting policies established for electric utilities in the Province of Ontario requires management to make estimates and assumptions that affect the reported amounts of assets and liabilities at the date of the financial statements, and the reported amounts of revenues and expenses during the reporting period. Actual results could differ from management's best estimates as additional information becomes available in the future.

Sioux Lookout Hydro Inc.
Notes to Financial Statements

December 31, 2006

1. Inventory

	2006	2005
Raw materials and supplies	\$ 65,936	\$ 45,679
Work in progress	2,681	8,359
	\$ 68,617	\$ 54,038

2. Due to/from Related Parties

At the end of the year, the amounts due to/from related parties are as follows:

	2006	2005
Due to Shareholder:		
Corporation of the Municipality of Sioux Lookout	\$ 423,500	\$ 286,487
Due from wholly owned subsidiary of shareholder:		
Sioux Hudson Energy Inc.	\$ 49,164	\$ 52,624

These balances are interest free, payable on demand and have arisen from the transfer of assets, dividends declared and provision of services referred to below.

The Corporation provides billing services to Corporation of the Municipality of Sioux Lookout for sewer and water. At year end, the uncollected bills from customers was \$133,611. As well, there was a dividend declared and payable of \$285,158. During the year, the company billed electricity and services to the shareholder in the amount of \$567,492.

The Corporation provides billing services to Sioux Hudson Energy Inc. for hot water tank rentals. When collected, amounts billed are forwarded to Sioux Hudson Energy Inc.

These transactions are in the normal course of operations and are measured at the exchange value (the amount of consideration established and agreed to by the related parties), which approximates the arm's length equivalent value for sales of product.

Sioux Lookout Hydro Inc.
Notes to Financial Statements

December 31, 2006

3. Regulatory Assets (Liabilities)

Under Bill 210, certain costs and variance account balances are deemed to be "regulatory assets (liabilities)" in accordance with the OEB Accounting Procedures Handbook. These assets are to be reflected on the Corporation's balance sheet. The OEB has granted the Corporation permission to recover the regulatory assets when establishing its distribution rates. The manner and timing of the regulatory liabilities has not been determined by the OEB.

	2006	2005
Retail settlement variances	\$ 10,539	\$ 7,333
Wholesale market service variances	117,129	170,486
Network charges variances	(39,903)	2,209
Connection charges variances	(491,838)	(725,500)
Power charges variances	523,350	374,488
Pre-market opening energy variance	276,745	276,745
Rate Rider variance	(4,574)	-
Transitional costs	41,443	38,185
Less assets recovered through rates	(714,457)	(316,102)
	\$ (281,566)	\$ (172,156)

4. Capital Assets

	2006		2005	
	Cost	Accumulated Amortization	Cost	Accumulated Amortization
Buildings	\$ 91,864	\$ 22,649	\$ 91,864	\$ 18,974
Distribution system-overhead	3,707,834	820,943	3,591,695	672,630
Distribution system				
- underground	819,572	180,012	791,541	147,229
Distribution transformers	1,294,176	289,966	1,281,875	238,199
Distribution meters	326,902	64,270	284,580	51,388
Other equipment - various	607,703	359,928	600,964	289,422
Contributions and Grants	(474,387)	(68,270)	(384,206)	(49,295)
	\$ 6,373,664	\$ 1,669,498	\$ 6,258,313	\$ 1,368,547
Net book value		\$ 4,704,166		\$ 4,889,766

Sioux Lookout Hydro Inc.
Notes to Financial Statements

December 31, 2006

5. Bank Indebtedness

	2006	2005
Demand instalment loan, repayable at \$11,666 per month plus interest at prime, secured by a general security agreement covering all assets; due 2018	<u>\$ 1,621,667</u>	<u>\$ 1,761,667</u>

The bank operating loan is due on demand and bears interest at the bank's prime rate, calculated and payable monthly. It is secured by a general security agreement covering all assets.

The company has an unused operating line of credit of \$175,000 with terms of due on demand and bears interest at the bank's prime rate calculated and payable monthly.

For bank indebtedness it is not practicable within the constraints of timeliness or cost to determine the fair value with sufficient reliability because the instruments are not traded in an organized financial market.

6. Employee Benefits Payable

	2006	2005
Vacation pay	\$ 4,108	\$ 5,457
Vested sick leave	51,530	88,738
Banked overtime	3,922	5,581
Post employment benefits	<u>42,739</u>	<u>32,978</u>
	<u>\$ 102,299</u>	<u>\$ 132,754</u>

7. Payment in Lieu of Taxes

Future payments in lieu of taxes have not been recorded in the accounts as they are expected to be reflected through future distribution revenues. As at December 31, 2006 a future income tax asset of \$70,598 (2005 - \$63,358) has not been recorded on the balance sheet. A future payment in lieu of taxes recovery of \$7,240 (2005 - \$7,731) has not been reflected in the income tax provision for the year ended December 31, 2006.

Sioux Lookout Hydro Inc. Notes to Financial Statements

December 31, 2006

8. Share Capital

The authorized class A preference share capital of the company is an unlimited number of non-voting shares, with a stated value equal to the consideration received on issue, redeemable and retractable at \$1,000 per share, and entitled to a non-cumulative annual dividend of 6%.

The authorized class B preference share capital of the company is an unlimited number of non-voting shares, redeemable and retractable at \$100 per share, and entitled to a non-cumulative annual dividend of 6%.

The authorized class C preference share capital of the company is an unlimited number of non-voting shares, redeemable and retractable at \$1 per share, and entitled to a non-cumulative annual dividend of 6%.

The authorized class D preference share capital of the company is an unlimited number of voting shares, redeemable and retractable at \$1 per share, and entitled to a non-cumulative annual dividend of 6%.

The authorized common share capital of the company is an unlimited number of shares.

The issued share capital is as follows:

	<u>2006</u>	<u>2005</u>
100 Common shares	<u>\$ 4,016,312</u>	<u>\$ 4,016,312</u>

9. Financial Guarantees

Participants in the wholesale market for electricity that is administered by the Independent Electricity Market Operator are required to satisfy prescribed prudential requirements.

During the year the Corporation was party to an irrevocable letter of credit with a Canadian Chartered bank. The letter of credit amount was 2006 - \$725,356 (2005 - \$381,088).

Sioux Lookout Hydro Inc.
Notes to Financial Statements

December 31, 2006

10. Other Operating Revenue

	2006	2005
Late payment charges	\$ 54,829	\$ 54,863
Interest income	43,017	20,976
Pole rentals	42,027	37,198
Administration fees	7,006	5,528
Change in occupancy charges	13,410	7,648
Prior year variance adjustment	-	20,979
Sentinel light rental	9,176	9,027
Sundry	14,815	13,181
	\$ 184,280	\$ 169,400

11. Pension Agreement

The Commission makes contributions to the Ontario Municipal Employers Retirement Fund (OMERS), which is a multi-employer plan, on behalf of seven members of its staff. The plan is a deferred benefit plan which specifies the amount of the retirement benefit to be received by the employee based on the length of service and rate of pay.

The amount contributed to OMERS for 2006 was \$29,287 (2005 - \$25,120) for current service which is normally included as an expenditure in the statement of operations.

12. Supplementary Cash Flow Information

	2006	2005
Interest paid	\$ 154,519	\$ 119,986
Payment in lieu of taxes paid	29,860	57,817
	\$ 184,379	\$ 177,803

Sioux Lookout Hydro Inc.
Notes to Financial Statements

December 31, 2006

13. Amortization of Capital Assets

	2006	2005
Amortization of building and distribution equipment	\$ 247,164	\$ 241,937
Amortization of office equipment	1,813	5,591
Amortization of Contributions and Grants	(18,975)	(15,368)
	<u>230,002</u>	<u>232,160</u>
Amortization of other capital assets included in relevant expense categories		
Rolling stock	51,503	44,665
Operations and maintenance	17,463	26,798
Sentinel lights	1,981	1,881
	<u>\$ 300,949</u>	<u>\$ 305,504</u>

14. Commitments

The company has also entered into an operating lease for its equipment (Altec Aerial Device). The equipment is leased at \$3,176 per month under a lease expiring in 2013.

The minimum annual lease payments for the next five years are as follows:

2007	\$ 38,112
2008	38,112
2009	38,112
2010	38,112
2011	38,112

15. Financial Instruments

Unless otherwise noted, it is management's opinion that the company is not exposed to significant interest, currency or credit risks arising from its financial instruments. The fair value of the financial instruments approximates their carrying values, unless otherwise noted.

16. Credit Risk

Sioux Lookout Hydro Inc. is in the normal course of operations, exposed to credit risk from having bank account balances over the amounts insured by the Canadian Deposit Insurance Corporation.

SIoux LOOKOUT HYDRO INC.**PRO FORMA FINANCIAL STATEMENTS****AT**
DECEMBER 31 2007Balance Sheet

Description	Total
1050-Current Assets	3,586,944
1100-Inventory	65,936
1200-Other Assets and Deferred Charges	-490,458
1300-Intangible Plant	0
1450-Distribution Plant	5,071,690
1500-General Plant	123,043
1550-Other Capital Assets	303,660
1600-Accumulated Amortization	-385,743
1650-Current Liabilities	-583,975
1700-Non-Current Liabilities	-177,718
1800-Long-Term Debt	-4,353,157
1850-Shareholders' Equity	<u>-3,160,221</u>
Balance Sheet Total	0.00

Profit and Loss

Description	Total
3000-Sales of Electricity	-7,454,659
3050-Revenues From Services - Distirbution	-1,491,686
3100-Other Operating Revenues	-116,149
3150-Other Income & Deductions	32,421
3200-Investment Income	-43,000
3350-Power Supply Expenses	7,454,659
3500-Distribution Expenses - Operation	402,439
3550-Distribution Expenses - Maintenance	90,755
3650-Billing and Collecting	347,815
3700-Community Relations	0
3800-Administrative and General Expenses	278,284
3850-Amortization Expense	239,466
3900-Interest Expense	176,054
3950-Taxes Other Than Income Taxes	8,700
4000-Income Taxes	<u>13,100</u>
Net Income	-61,802

SIoux LOOKOUT HYDRO INC.**PRO-FORMA FINANCIAL STATEMENTS****AT**
DECEMBER 31 2008Balance Sheet

Description	Total
1050-Current Assets	3,586,944
1100-Inventory	65,936
1200-Other Assets and Deferred Charges	942,745
1300-Intangible Plant	0
1450-Distribution Plant	5,566,800
1500-General Plant	213,043
1550-Other Capital Assets	303,660
1600-Accumulated Amortization	-576,947
1650-Current Liabilities	-3,626,903
1700-Non-Current Liabilities	-177,718
1800-Long-Term Debt	-2,712,323
1850-Shareholders' Equity	<u>-3,585,238</u>
Balance Sheet Total	0

Profit and Loss

Description	Total
3000-Sales of Electricity	-7,518,122
3050-Revenues From Services - Distirbution	-1,532,447
3100-Other Operating Revenues	-116,149
3150-Other Income & Deductions	-12,579
3200-Investment Income	-45,000
3350-Power Supply Expenses	7,518,122
3500-Distribution Expenses - Operation	421,827
3550-Distribution Expenses - Maintenance	87,282
3650-Billing and Collecting	366,827
3700-Community Relations	0
3800-Administrative and General Expenses	260,891
3850-Amortization Expense	257,984
3900-Interest Expense	180,142
3950-Taxes Other Than Income Taxes	8,700
4000-Income Taxes	<u>0</u>
Net Income	-122,522

SIOUX LOOKOUT HYDRO INC.**RECONCILIATION BETWEEN FINANCIAL STATEMENTS AND FINANCIAL RESULTS FILED**

The reconciliation of the SLHI net income presented in the audited financial statements and net income included in the Reporting and Record-Keeping Requirements ("RRR") filing, for the year ended December 31, 2006, is presented below.

Net Income included in RRR for year-end December 31, 2006

Net Income	2005 Actual	2006 Actual
Audited Financial Statements	<u>\$59,225</u>	<u>\$128,542</u>
RRR (USofA Account 3046)	<u>\$59,225</u>	<u>\$128,542</u>
Difference	<u>\$0</u>	<u>\$0</u>

SIoux LOOKOUT HYDRO INC.

PROPOSED ACCOUNTING TREATMENT

The following information relates to the accounting treatment of long lived assets. Long-lived assets include property, plant and equipment and intangibles that are subject to amortization.

Property, plant and equipment are stated at cost and are removed from the accounts at the end of their estimated average service lives, except in those instances where specific identification allows their removal at retirement or disposition. Gains or losses at retirement or disposition of such assets are credited or charged to "Other income" in the Statement of Income. In the event that facts and circumstances indicate that property, plant and equipment may be impaired, an evaluation of recoverability is performed. For purposes of such an evaluation, the estimated future discounted cash flows associated with the asset are compared to the carrying amount of the asset to determine if a write-down is required.

The impairment loss is measured as the amount by which the carrying amount of the assets exceeds its fair value.

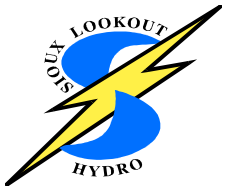
**SIOUX LOOKOUT HYDRO INC.**

<u>Ex.</u>	<u>Tab</u>	<u>Schedule</u>	<u>Contents of Schedule</u>
<u>2 – Rate Base</u>			
	1		<u>Overview</u>
		1	Rate Base Overview
		2	Rate Base Summary Table
		3	Variance Analysis on Rate Base Table
	2		<u>Gross Assets – Property, Plant and Equipment</u>
			<u>Accumulated Depreciation</u>
		1	Continuity Statements
		2	Gross Assets Table
		3	Materiality Analysis on Gross Assets
		4	Accumulated Depreciation Table
		5	Materiality Analysis on Accumulated Depreciation
	3		<u>Capital Budget</u>
		1	Capital Budget by Project
		2	Description of Capital Plan including Materiality Analysis on Capital Additions
		3	System Expansion
		4	Capitalization Policy
	4		<u>Allowance for Working Capital</u>
		1	Working Capital Allowance calculations by account



SIOUX-LOOKOUT HYDRO INC.

RATE BASE OVERVIEW

Introduction

A projection of SLHI's rate base is provided for both the Bridge Year (2007) and the Test Year (2008). Historical data pertaining to rate base is also presented for 2006 Board approved and 2006 Actual. SLHI Inc.'s forecast rate base for the test year is \$6,366,551. The rate base underlying the test year revenue requirement includes a forecast of net fixed assets, plus a working capital allowance. Net fixed assets are gross assets in service minus accumulated depreciation and contributed capital. Details for SLHI Inc.'s working capital allowance are provided in Exhibit 2, Tab 4, Schedule 1.

The bridge and test year's gross asset balance reflects the capital expenditure programs forecast for both years. These programs are described in detail in the company's written evidence at Exhibits 2, Tab 3, and Schedule 1. The justification for capital projects in excess of 1% of the net fixed assets are filed also at Exhibit 2, Tab 3, Schedule 2.



SIOUX-LOOKOUT HYDRO INC.

RATE BASE SUMMARY TABLE

RATE BASE SUMMARY	2006 Board Approved	2006 Actual	Variance form 2006 Board Approved	2006 Actual	2007 Bridge	Variance form 2006 Actual	Year End Average	2007 Bridge	2008 Test	Variance form 2007 Bridge	Year End Average	Variance form 2007 Bridge (Year End Avg)
	(\$'s)	(\$'s)	(\$'s)	(\$'s)	(\$'s)	(\$'s)		(\$'s)	(\$'s)	(\$'s)		(\$'s)
Gross Asset												
Asset Values at Cost	5,834,557.45	6,373,664.00	539,106.55	6,373,664.00	6,708,954.00	335,290.00	6,541,309.00	6,708,954.00	7,294,064.00	585,110.00	7,001,509.00	460,200.00
Accumulated Depreciation												
Depreciation	(933,529.86)	(1,669,498.00)	(735,968.15)	(1,669,498.00)	(1,971,510.00)	(302,012.00)	(1,820,504.00)	(1,971,510.00)	(2,227,834.00)	(256,324.00)	(2,099,672.00)	(279,168.00)
Net Fixed Asset	4,901,027.60	4,704,166.00	(196,861.59)	4,704,166.00	4,737,444.00	33,278.00	4,720,805.00	4,737,444.00	5,066,230.00	328,786.00	4,901,837.00	181,032.00
Allowance for Working Capital	1,002,935.09	1,134,554.70	131,619.61	1,134,554.70	1,401,587.85	267,033.15	1,401,587.85	1,401,587.85	1,464,714.15	63,126.30	1,464,714.15	63,126.30
Utility Rate Base	5,903,962.68	5,838,720.70	(65,241.98)	5,838,720.70	6,139,031.85	300,311.15	6,122,392.85	6,139,031.85	6,530,944.15	391,912.30	6,366,551.15	244,158.30

X



SIOUX-LOOKOUT HYDRO INC.

VARIANCE ANALYSIS ON RATE BASE SUMMARY TABLE

2008 Test Year

As shown in Exhibit 2, Tab1, Schedule 2, the total rate base in the 2008 test year is forecast to be \$6,366,551.15. The rate base for 2008 Test was calculated using an average of the year end gross plant and accumulated depreciation. Net fixed assets accounts for \$4,901,837 of this total. The allowance for working capital totals \$1,464,714.

Comparison to 2007 Bridge Year (Year End Average)

The total rate base is expected to be \$6,366,551 or 3.99% higher in the 2008 test year than in the 2007 bridge year. The increase is comprised of \$181,032 in net capital additions and \$63,126 in working capital allowance. SLHI's Capital Plans is detailed in Exhibit 2, Tab 3, Schedule 1 and 2 of this application.

2007 Bridge Year

As shown in Exhibit 2, Tab1, Schedule 2, the total rate base in the 2007 bridge year is forecast to be \$6,139,031 Net fixed assets accounts for \$4,737,444 of this total. The allowance for working capital totals \$1,401,587.

Comparison to 2006 Actual

The total rate base is expected to be \$6,139,031 or 5.14% higher in the 2007 bridge year than in the 2006 actual year. The increase is comprised of \$33,278 in net capital additions and \$267,033 in working capital allowance. SLHI's Capital Plans is detailed in Exhibit 2, Tab 3, Schedule 1 and 2 of this application.

2006 Actual

As shown in Exhibit 2, Tab1, Schedule 2, the total rate base in the 2006 actual year is established as being \$5,838,720 Net fixed assets accounts for \$4,704,166 of this total. The allowance for working capital totals \$1,134,554.



SIOUX-LOOKOUT HYDRO INC.

Comparison to 2006 Board Approved

The total rate base for 2006 actual was \$5,838,720 or 1.0% lower in the 2006 actual year than in the 2006 board approved year. The decrease is comprised of \$196,861 in net capital additions and \$131,619 in working capital allowance. SLHI's Capital Plans is detailed in Exhibit 2, Tab 3, Schedule 1 and 2 of this application.

2006 Board Approved

As shown in Exhibit 2, Tab1, Schedule 2, the total rate base in the 2006 board approved year was \$5,903,962 Net fixed assets accounts for \$4,901,027 of this total. The allowance for working capital totals \$1,002,935.



SIOUX-LOOKOUT HYDRO INC.

CONTINUITY STATEMENTS	2006 Actual			2007 Bridge			2008 Test		
	Gross Asset Value	Accumulated Depreciation	Net Book Value	Gross Asset Value	Accumulated Depreciation	Net Book Value	Gross Asset Value	Accumulated Depreciation	Net Book Value
Line Transformers									
1850-Line Transformers-Opening Balance	1,281,875.27	-238,199.38	1,043,675.89	1,294,176.33	-289,966.41	1,004,209.92	1,294,176.33	-341,733.46	952,442.87
1850-Line Transformers-Additions	12,301.06	0.00	12,301.06	0.00	0.00	0.00	2,700.00	0.00	2,700.00
1850-Line Transformers-Depreciation	0.00	-51,767.03	-51,767.03	0.00	-51,767.05	-51,767.05	0.00	-51,821.05	-51,821.05
1850-Line Transformers-Adjustments	0.00	0.00	0.00	0.00	0.00	0.00	0.00	0.00	0.00
1850-Line Transformers-Closing Balance	1,294,176.33	-289,966.41	1,004,209.92	1,294,176.33	-341,733.46	952,442.87	1,296,876.33	-393,554.52	903,321.81
Average	1,288,025.80	-264,082.90	1,023,942.91	1,294,176.33	-315,849.94	978,326.39	1,295,526.33	-367,643.99	927,882.34
Total									
1860-Meters-Opening Balance	284,579.80	-51,388.02	233,191.78	326,901.51	-64,269.50	262,632.01	382,901.51	-69,465.56	313,435.95
1860-Meters-Additions	43,626.31	0.00	43,626.31	65,000.00	0.00	65,000.00	270,000.00	0.00	270,000.00
1860-Meters-Depreciation	0.00	-13,403.38	-13,403.38	0.00	-14,196.06	-14,196.06	0.00	-19,380.46	-19,380.46
1860-Meters-Adjustments	-1,304.60	521.90	-782.70	-9,000.00	9,000.00	0.00	-66,780.00	66,780.00	0.00
1860-Meters-Closing Balance	326,901.51	-64,269.50	262,632.01	382,901.51	-69,465.56	313,435.95	586,121.51	-22,066.02	564,055.49
Average	305,740.66	-57,828.76	247,911.90	354,901.51	-66,867.53	288,033.98	484,511.51	-45,765.79	438,745.72
Total									
IT Assets									
1920-Computer Equipment - Hardware-Opening Balance	19,832.94	-17,387.96	2,444.98	20,944.24	-18,530.82	2,413.42	20,944.24	-20,944.24	0.00
1920-Computer Equipment - Hardware-Additions	1,111.30	0.00	1,111.30	0.00	0.00	0.00	0.00	0.00	0.00
1920-Computer Equipment - Hardware-Depreciation	0.00	-1,142.86	-1,142.86	0.00	-2,413.42	-2,413.42	0.00	0.00	0.00
1920-Computer Equipment - Hardware-Adjustments	0.00	0.00	0.00	0.00	0.00	0.00	0.00	0.00	0.00
1920-Computer Equipment - Hardware-Closing Balance	20,944.24	-18,530.82	2,413.42	20,944.24	-20,944.24	0.00	20,944.24	-20,944.24	0.00
Average	20,388.59	-17,959.39	2,429.20	20,944.24	-19,737.53	1,206.71	20,944.24	-20,944.24	0.00
Total									
1925-Computer Software-Opening Balance	0.00	0.00	0.00	0.00	0.00	0.00	2,000.00	-200.00	1,800.00
1925-Computer Software-Additions	0.00	0.00	0.00	2,000.00	0.00	2,000.00	0.00	0.00	0.00
1925-Computer Software-Depreciation	0.00	0.00	0.00	0.00	-200.00	-200.00	0.00	-400.00	-400.00
1925-Computer Software-Adjustments	0.00	0.00	0.00	0.00	0.00	0.00	0.00	0.00	0.00
1925-Computer Software-Closing Balance	0.00	0.00	0.00	2,000.00	-200.00	1,800.00	2,000.00	-600.00	1,400.00
Average	0.00	0.00	0.00	1,000.00	-100.00	900.00	2,000.00	-400.00	1,600.00
Total									
Equipment									
1915-Office Furniture and Equipment-Opening Balance	6,706.66	-2,843.07	3,863.59	6,706.66	-3,513.64	3,193.02	8,706.66	-4,284.31	4,422.35
1915-Office Furniture and Equipment-Additions	0.00	0.00	0.00	2,000.00	0.00	2,000.00	0.00	0.00	0.00
1915-Office Furniture and Equipment-Depreciation	0.00	-670.57	-670.57	0.00	-770.67	-770.67	0.00	-870.67	-870.67
1915-Office Furniture and Equipment-Adjustments	0.00	0.00	0.00	0.00	0.00	0.00	0.00	0.00	0.00
1915-Office Furniture and Equipment-Closing Balance	6,706.66	-3,513.64	3,193.02	8,706.66	-4,284.31	4,422.35	8,706.66	-5,154.97	3,551.69
Average	6,706.66	-3,178.36	3,528.31	7,706.66	-3,898.97	3,807.69	8,706.66	-4,719.64	3,987.02
Total									
1930-Transportation Equipment-Opening Balance	365,285.96	-146,421.87	218,864.09	365,285.96	-196,517.68	168,768.28	365,285.96	-242,178.43	123,107.54



SIOUX-LOOKOUT HYDRO INC.

CONTINUITY STATEMENTS	2006 Actual			2007 Bridge			2008 Test		
	Gross Asset Value	Accumulated Depreciation	Net Book Value	Gross Asset Value	Accumulated Depreciation	Net Book Value	Gross Asset Value	Accumulated Depreciation	Net Book Value
1930-Transportation Equipment-Additions	0.00	0.00	0.00	0.00	0.00	0.00	80,000.00		80,000.00
1930-Transportation Equipment-Depreciation	0.00	-50,095.81	-50,095.81	0.00	-45,660.75	-45,660.75		-50,660.75	-50,660.75
1930-Transportation Equipment-Adjustments	0.00	0.00	0.00	0.00	0.00	0.00	0.00	0.00	0.00
1930-Transportation Equipment-Closing Balance	365,285.96	-196,517.68	168,768.28	365,285.96	-242,178.43	123,107.54	445,285.96	-292,839.17	152,446.79
Average	365,285.96	-171,469.78	193,316.19	365,285.96	-219,348.05	145,937.91	405,285.96	-267,508.80	137,777.16
1940-Tools, Shop and Garage Equipment-Opening Balance	46,723.44	-19,039.95	27,683.49	48,493.03	-23,889.24	24,603.79	53,493.03	-28,988.54	24,504.49
1940-Tools, Shop and Garage Equipment-Additions	1,769.59	0.00	1,769.59	5,000.00	0.00	5,000.00	5,000.00	0.00	5,000.00
1940-Tools, Shop and Garage Equipment-Depreciation	0.00	-4,849.29	-4,849.29	0.00	-5,099.30	-5,099.30	0.00	-5,599.30	-5,599.30
1940-Tools, Shop and Garage Equipment-Adjustments	0.00	0.00	0.00	0.00	0.00	0.00	0.00	0.00	0.00
1940-Tools, Shop and Garage Equipment-Closing Balance	48,493.03	-23,889.24	24,603.79	53,493.03	-28,988.54	24,504.49	58,493.03	-34,587.85	23,905.18
Average	47,608.24	-21,464.60	26,143.64	50,993.03	-26,438.89	24,554.14	55,993.03	-31,788.19	24,204.84
1945-Measurement and Testing Equipment-Opening Balance	9,351.19	-2,036.95	7,314.24	12,187.81	-3,255.73	8,932.08	15,187.81	-4,624.51	10,563.30
1945-Measurement and Testing Equipment-Additions	2,836.62	0.00	2,836.62	3,000.00	0.00	3,000.00	3,000.00	0.00	3,000.00
1945-Measurement and Testing Equipment-Depreciation	0.00	-1,218.78	-1,218.78	0.00	-1,368.78	-1,368.78	0.00	-1,668.78	-1,668.78
1945-Measurement and Testing Equipment-Adjustments	0.00	0.00	0.00	0.00	0.00	0.00	0.00	0.00	0.00
1945-Measurement and Testing Equipment-Closing Balance	12,187.81	-3,255.73	8,932.08	15,187.81	-4,624.51	10,563.30	18,187.81	-6,293.29	11,894.52
Average	10,769.50	-2,646.34	8,123.16	13,687.81	-3,940.12	9,747.69	16,687.81	-5,458.90	11,228.91
1950-Power Operated Equipment-Opening Balance	109,995.61	-81,707.15	28,288.46	108,187.11	-89,485.23	18,701.88	108,187.11	-103,008.62	5,178.49
1950-Power Operated Equipment-Additions	0.00	0.00	0.00	0.00	0.00	0.00	0.00	0.00	0.00
1950-Power Operated Equipment-Depreciation	0.00	-8,644.56	-8,644.56	0.00	-13,523.39	-13,523.39	0.00	-5,178.49	-5,178.49
1950-Power Operated Equipment-Adjustments	-1,808.50	866.48	-942.02	0.00	0.00	0.00	0.00	0.00	0.00
1950-Power Operated Equipment-Closing Balance	108,187.11	-89,485.23	18,701.88	108,187.11	-103,008.62	5,178.49	108,187.11	-108,187.11	0.00
Average	109,091.36	-85,596.19	23,495.17	108,187.11	-96,246.92	11,940.19	108,187.11	-105,597.86	2,589.25
1955-Communication Equipment-Opening Balance	24,251.16	-11,887.82	12,363.34	26,091.89	-14,657.36	11,434.53	35,491.89	-17,736.55	17,755.34
1955-Communication Equipment-Additions	1,840.73	0.00	0.00	9,400.00	0.00	9,400.00	2,000.00	0.00	2,000.00
1955-Communication Equipment-Depreciation	0.00	-2,769.54	-2,769.54	0.00	-3,079.19	-3,079.19	0.00	-3,649.19	-3,649.19
1955-Communication Equipment-Adjustments	0.00	0.00	0.00	0.00	0.00	0.00	0.00	0.00	0.00
1955-Communication Equipment-Closing Balance	26,091.89	-14,657.36	11,434.53	35,491.89	-17,736.55	17,755.34	37,491.89	-21,385.74	16,106.15
Average	25,171.53	-13,272.59	11,898.94	30,791.89	-16,196.95	14,594.94	36,491.89	-19,561.14	16,930.75
1985-Sentinel Lighting Rental Units-Opening Balance	18,816.61	-8,097.72	10,718.89	19,806.06	-10,078.31	9,727.75	19,806.06	-12,058.92	7,747.14
1985-Sentinel Lighting Rental Units-Additions	989.45	0.00	0.00	0.00	0.00	0.00	0.00	0.00	0.00
1985-Sentinel Lighting Rental Units-Depreciation	0.00	-1,980.59	-1,980.59	0.00	-1,980.61	-1,980.61	0.00	-1,980.61	-1,980.61
1985-Sentinel Lighting Rental Units-Adjustments	0.00	0.00	0.00	0.00	0.00	0.00	0.00	0.00	0.00
1985-Sentinel Lighting Rental Units-Closing Balance	19,806.06	-10,078.31	9,727.75	19,806.06	-12,058.92	7,747.14	19,806.06	-14,039.52	5,766.54
Average	19,311.34	-9,088.02	10,223.32	19,806.06	-11,068.61	8,737.45	19,806.06	-13,049.22	6,756.84



SIOUX-LOOKOUT HYDRO INC.

CONTINUITY STATEMENTS	2006 Actual			2007 Bridge			2008 Test		
	Gross Asset Value	Accumulated Depreciation	Net Book Value	Gross Asset Value	Accumulated Depreciation	Net Book Value	Gross Asset Value	Accumulated Depreciation	Net Book Value
1995-Contributions and Grants - Credit-Opening Balance	-384,205.96	49,294.61	-334,911.35	-474,387.02	68,270.09	-406,116.93	-474,387.02	87,245.57	-387,141.45
1995-Contributions and Grants - Credit-Additions	-90,181.06	0.00	-90,181.06	0.00	0.00	0.00	0.00	0.00	0.00
1995-Contributions and Grants - Credit-Depreciation	0.00	18,975.48	18,975.48	0.00	18,975.48	18,975.48	0.00	18,975.48	18,975.48
1995-Contributions and Grants - Credit-Adjustments	0.00	0.00	0.00	0.00	0.00	0.00	0.00	0.00	0.00
1995-Contributions and Grants - Credit-Closing Balance	-474,387.02	68,270.09	-406,116.93	-474,387.02	87,245.57	-387,141.45	-474,387.02	106,221.05	-368,165.97
Average	-429,296.49	58,782.35	-370,514.14	-474,387.02	77,757.83	-396,629.19	-474,387.02	96,733.31	-377,653.71
Total									
Total Opening Balance	6,258,313.60	-1,368,548.51	4,889,765.09	6,373,663.74	-1,669,497.80	4,704,165.94	6,708,953.74	-1,971,510.14	4,737,443.60
Total Additions	118,463.24	0.00	115,633.06	344,290.00	0.00	344,290.00	651,890.00	0.00	651,890.00
Total Depreciation	0.00	-302,337.67	-302,337.67	0.00	-311,012.34	-311,012.34	0.00	-323,104.02	-323,104.02
Total Adjustments	-3,113.10	1,388.38	-1,724.72	-9,000.00	9,000.00	0.00	-66,780.00	66,780.00	0.00
Total Closing Balance	6,373,663.74	-1,669,497.80	4,704,165.94	6,708,953.74	-1,971,510.14	4,737,443.60	7,294,063.74	-2,227,834.16	5,066,229.58
Average	6,315,988.67	-1,519,023.16	4,796,965.52	6,541,308.74	-1,820,503.97	4,720,804.77	7,001,508.74	-2,099,672.15	4,901,836.59

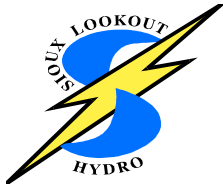

SIOUX-LOOKOUT HYDRO INC.

	2006 Board Approved	2006 Actual	Variance form 2006 Board Approved	2006 Actual	2007 Bridge	Variance form 2006 Actual	2007 Bridge	2008 Test	Variance form 2006 Actual
GROSS ASSET									
1910-Leasehold Improvements									
Sub-Total-General Plant									
IT Assets									
1920-Computer Equipment - Hardware	21,713.00	20,944.00	-769.00	20,944.00	20,944.00	0.00	20,944.00	20,944.00	0.00
1925-Computer Software	0.00	0.00	0.00	0.00	2,000.00	2,000.00	2,000.00	2,000.00	0.00
Sub-Total-IT Assets	21,713.00	20,944.00	-769.00	20,944.00	22,944.00	2,000.00	22,944.00	22,944.00	0.00
Equipment									
1915-Office Furniture and Equipment	5,521.00	6,707.00	1,186.00	6,707.00	8,707.00	2,000.00	8,707.00	8,707.00	0.00
1930-Transportation Equipment	321,228.00	365,286.00	44,058.00	365,286.00	365,286.00	0.00	365,286.00	445,286.00	80,000.00
1935-Stores Equipment	0.00	0.00	0.00	0.00	0.00	0.00	0.00	0.00	0.00
1940-Tools, Shop and Garage Equipment	39,644.00	48,493.00	8,849.00	48,493.00	53,493.00	5,000.00	53,493.00	58,493.00	5,000.00
1945-Measurement and Testing Equipment	6,295.00	12,188.00	5,893.00	12,188.00	15,188.00	3,000.00	15,188.00	18,188.00	3,000.00
1950-Power Operated Equipment	98,332.00	108,187.00	9,855.00	108,187.00	108,187.00	0.00	108,187.00	108,187.00	0.00
1955-Communication Equipment	23,248.00	26,092.00	2,844.00	26,092.00	35,492.00	9,400.00	35,492.00	37,492.00	2,000.00
1960-Miscellaneous Equipment	0.00	0.00	0.00	0.00	0.00	0.00	0.00	0.00	0.00
Sub-Total-Equipment	494,268.00	566,953.00	72,685.00	566,953.00	586,353.00	19,400.00	586,353.00	676,353.00	90,000.00
Other Distribution Assets									
1825-Storage Battery Equipment									
1970-Load Management Controls - Customer Premises									
1975-Load Management Controls - Utility Premises									
1980-System Supervisory Equipment									
1985-Sentinel Lighting Rental Units	0.00	19,806.00	19,806.00	19,806.00	19,806.00	0.00	19,806.00	19,806.00	0.00
1990-Other Tangible Property	0.00	0.00	0.00	0.00	0.00	0.00	0.00	0.00	0.00
1995-Contributions and Grants - Credit	-310,303.00	-474,387.00	-164,084.00	-474,387.00	-474,387.00	0.00	-474,387.00	-474,387.00	0.00
Sub-Total-Other Distribution Assets	-310,303.00	-454,581.00	-144,278.00	-454,581.00	-454,581.00	0.00	-454,581.00	-454,581.00	0.00
Utility Gross Asset									
Total	5,834,558.00	6,373,663.00	539,105.00	6,373,663.00	6,708,953.00	335,290.00	6,708,953.00	7,294,063.00	585,110.00



SIOUX-LOOKOUT HYDRO INC.

MATERIALITY ANALYSIS ON GROSS ASSET

2006 Board Approved VS 2006 Actual

Asset Account	2006 Board Approved	2006 Actual	Variance
1830-Poles, Towers and Fixtures	2,776,720.00	2,628,662.00	-148,058.00
1835-Overhead Conductors and Devices	537,916.00	1,079,172.00	541,256.00

The 2006 Board approved amounts are based on an average generated by the 2006 EDR model of 2003 and 2004 data. Prior to 2004, accounts 1830 and 1835 were combined into one account 1830. In 2004, an analysis was done, and the amounts for Overhead Conductors and Devices was extracted from account 1830 and moved to account 1835. This explains why the 2006 Board approved amount for 1830 is higher than the 2006 actual, and why the 2006 Board Approved amount for 1835 is half of the 2006 actual.

Asset Account	2006 Board Approved	2006 Actual	Variance
1840-Underground Conduit	425,043.00	152,957.00	-272,086.00
1845-Underground Conductors and Devices	305,724.00	666,614.00	360,890.00

Similar to the above explanation, prior to 2004 accounts 1840 and 1845 were combined into one account 1840. In 2004, an analysis was done, and the amounts for Underground Conductors and Devices was extracted from account 1840 and included in account 1845. This explains why the 2006 Board approved figure is higher than the 2006 actual for account 1840, and why the 2006 Board Approved amount for 1845 is half of the 2006 actual.

Asset Account	2006 Board Approved	2006 Actual	Variance
1850-Line Transformers	1,205,532.00	1,294,176.00	88,644.00



SIOUX-LOOKOUT HYDRO INC.

Because the 2006 Board Approved amount is an average of 2003 and 2004 balances, the figure used was less than the actual 2004 balance of \$1,255,583. In 2005 \$26,000 was added to transformer capital and in 2006 \$12,000 was added.

Asset Account	2006 Board Approved	2006 Actual	Variance
1995-Contributions and Grants - Credit	-310,303.00	-474,387.00	-164,084.00

The balance in 1995 at the end of 2004 was \$(351,970). In 2005 \$32,235 was received for contributed capital. The majority of this amount consists of contributions towards new underground services, along with approximately \$11,000 for contributed transformer capital for a new general service > 50 KW customer.

In 2006 \$90,181 was received for contributed capital. There was contributed capital for the development of a new subdivision, a large metering project as well as contributed transformer capital for a new water treatment plant.

2006 Actual VS 2007 Bridge

Asset Account	2006 Actual	2007 Bridge	Variance
1830-Poles, Towers and Fixtures	2,628,662.00	2,871,552.00	242,890.00

This variance is the result of several projects planned for 2007.

Asset Account	2006 Actual	2007 Bridge	Variance
1860-Meters	326,902.00	382,902.00	56,000.00

This variance is the result of \$50,000 budgeted for 2007 in relation to smart meters.

2007 Bridge VS 2008 Test

Asset Account	2006 Bridge	2008 Test	Variance
1830-Poles, Towers and Fixtures	2,871,552.00	3,145,742.00	274,190.00



SIOUX-LOOKOUT HYDRO INC.

This variance is the result of projects planned for 2008.

Asset Account	2006 Bridge	2008 Test	Variance
1860-Meters	382,902.00	586,122.00	203,220.00

This variance is the result of planned smart meter implementation

Asset Account	2006 Bridge	2008 Test	Variance
1930-Transportation Equipment	365,286.00	445,286.00	80,000.00

This variance is a result of a planned service truck replacement in 2008.



SIOUX-LOOKOUT HYDRO INC.
ACCUMULATED DEPRECIATION TABLE

ACCUMULATED DEPRECIATION TABLE	2006 Board Approved	2006 Actual	Variance form 2006 Board Approved	2006 Actual	2007 Bridge	Variance form 2006 Actual	2007 Bridge	2008 Test	Variance form 2007 Bridge
	(\$'s)	(\$'s)		(\$'s)	(\$'s)		(\$'s)	(\$'s)	
Land and Buildings									
1805-Land-Depreciation									
1806-Land Rights-Depreciation									
1808-Buildings and Fixtures-Depreciation	-13,463.00	-22,649.00	-9,186.00	-22,649.00	-26,324.00	-3,675.00	-26,324.00	-29,998.00	-3,674.00
1905-Land-Depreciation									
1906-Land Rights-Depreciation									
1810-Leasehold Improvements-Depreciation									
Sub-Total-Land and Buildings	-13,463.00	-22,649.00	-9,186.00	-22,649.00	-26,324.00	-3,675.00	-26,324.00	-29,998.00	-3,674.00
TS Primary Above 50									
1815-Transformer Station Equipment - Normally Primary above 50 kV-Depreciation									
Sub-Total-TS Primary Above 50									
DS									
1820-Distribution Station Equipment - Normally Primary below 50 kV-Depreciation									
Sub-Total-DS									
Poles and Wires									
1830-Poles, Towers and Fixtures-Depreciation	-361,446.00	-574,660.00	-213,214.00	-574,660.00	-684,664.00	-110,004.00	-684,664.00	-805,010.00	-120,346.00
1835-Overhead Conductors and Devices-Depreciation	-86,328.00	-246,283.00	-159,955.00	-246,283.00	-289,450.00	-43,167.00	-289,450.00	-332,617.00	-43,167.00
1840-Underground Conduit-Depreciation	-54,073.00	-36,002.00	18,071.00	-36,002.00	-42,141.00	-6,139.00	-42,141.00	-48,319.00	-6,178.00
1845-Underground Conductors and Devices-Depreciation	-38,726.00	-144,010.00	-105,284.00	-144,010.00	-170,954.00	-26,944.00	-170,954.00	-198,459.00	-27,505.00
Sub-Total-Poles and Wires	-540,573.00	-1,000,955.00	-460,382.00	-1,000,955.00	-1,187,209.00	-186,254.00	-1,187,209.00	-1,384,405.00	-197,196.00
Line Transformers									
1850-Line Transformers-Depreciation	-155,852.00	-289,966.00	-134,114.00	-289,966.00	-341,733.00	-51,767.00	-341,733.00	-393,555.00	-51,822.00
Sub-Total-Line Transformers	-155,852.00	-289,966.00	-134,114.00	-289,966.00	-341,733.00	-51,767.00	-341,733.00	-393,555.00	-51,822.00



SIOUX-LOOKOUT HYDRO INC.

	2006 Board Approved	2006 Actual	Variance form 2006 Board Approved	2006 Actual	2007 Bridge	Variance form 2006 Actual	2007 Bridge	2008 Test	Variance form 2007 Bridge
ACCUMULATED DEPRECIATION TABLE									
1985-Sentinel Lighting Rental Units-Depreciation	0.00	-10,078.00	-10,078.00	-10,078.00	-12,059.00	-1,981.00	-12,059.00	-14,040.00	-1,981.00
1990-Other Tangible Property-Depreciation									
1995-Contributions and Grants - Credit-Depreciation	0.00	68,270.00	68,270.00	68,270.00	87,246.00	18,976.00	87,246.00	106,221.00	18,975.00
Sub-Total-Other Distribution Assets	0.00	58,192.00	58,192.00	58,192.00	75,187.00	16,995.00	75,187.00	92,181.00	16,994.00
ACCUMULATED DEPRICIATION TOTAL	-933,530.00	-1,669,498.00	-735,968.00	-1,669,498.00	-1,971,511.00	-302,013.00	-1,971,511.00	-2,227,835.00	-256,324.00



SIOUX-LOOKOUT HYDRO INC.

MATERIALITY ANALYSIS ON ACCUMULATED DEPRICIATION

2006 Board Approved VS 2006 Actual

Asset Account	2006 Bridge	2008 Test	Variance
1930-Transportation Equipment	-83,608.00	-196,518.00	-112,910.00

The variance can be explained by the calculation done by the 2006 EDR model to determine the 2006 amount. The amounts were determined using an average of the 2003 and 2004 balances, which thereby reduced the actual amount in this account as of the end of 2004. Also a new truck was purchased in 2005 which increased depreciation expense for 2005 and 2006.

2006 Actual VS 2007 Bridge

Asset Account	2006 Bridge	2008 Test	Variance
1830 – Poles Towers and Fixtures – Depreciation	-574,660.00	-684,664.00	-110,004.00

This amount seems to be reasonable based on the planned additions an annual depreciation expense. In 2006 the expense was \$105,146 for account 1830.

Asset Account	2006 Bridge	2008 Test	Variance
1850 – Line Transformers – Depreciation	-289,966.00	-341,733.00	-51,767.00

This amount is equal to the 2006 expense for depreciation of transformers.

2007 Bridge VS 2008 Test

Asset Account	2006 Bridge	2008 Test	Variance
1930-Transportation Equipment	-242,178.00	-292839.00	-50,661.00

This amount is comparable to the 2006 depreciation expense for 2006.

Asset Account	2006 Bridge	2008 Test	Variance
1830- Poles, Towers and Fixtures – Depreciation	-684,664.00	-805010.00	-120,346.00

The variance of \$120,346 seems to be reasonable based on the planned additions for 2008

Asset Account	2006 Bridge	2008 Test	Variance
1850 – Line Transformers – Depreciation	-341,733.00	-393555	-51,822.00

The variance of \$51,822 seems to be reasonable based on the planned additions for 2008.

Asset Account	2006 Bridge	2008 Test	Variance
1860- Meters- Depreciation	-69,466.00	-22,066.00	-47,400.00

This variance is due to the estimated write off of conventional meters in 2008, due to smart metering initiatives.



SIOUX-LOOKOUT HYDRO INC.

CAPITAL BUDGET BY PROJECT

2007 Bridge

Project Description	USoA Account	Expansion or Enhancement	Amount
P00001 - Mill Line Upgrade	1830		100,000.00

Project Description	USoA Account	Expansion or Enhancement	Amount
P00002 - Hwy 72 South	1830		32,890.00

Project Description	USoA Account	Expansion or Enhancement	Amount
P00003 - Pole Replacement Program	1830		100,000.00

Project Description	USoA Account	Expansion or Enhancement	Amount
P00005 -New Connections	1830		10,000.00
	1845		14,000.00
	1840		1,000.00

Project Description	USoA Account	Expansion or Enhancement	Amount
P00006 - Smart Meters	1860		50,000.00

Project Description	USoA Account	Expansion or Enhancement	Amount
P00007 - Tools	1940		5,000.00
	1945		3,000.00
	1955		2,000.00

Project Description	USoA Account	Expansion or Enhancement	Amount
P00008 - Office Equipment	1915		2000.00

Project Description	USoA Account	Expansion or Enhancement	Amount
P00008 - Office Equipment	1915		2000.00



SIOUX-LOOKOUT HYDRO INC.

Project Description	USoA Account	Expansion or Enhancement	Amount
P00009 - Meter replacements	1860		15,000.00

Project Description	USoA Account	Expansion or Enhancement	Amount
P00010 - Phone system	1955		7,400.00
	1925		2,000.00

2008 Test

Project Description	USoA Account	Expansion or Enhancement	Amount
P00001 - Mill Line Upgrade	1830		131,300.00

Project Description	USoA Account	Expansion or Enhancement	Amount
P00002 - Hwy 72 South	1830		32,890.00
	1850		2,700.00

Project Description	USoA Account	Expansion or Enhancement	Amount
P00003 - Pole Replacement Program	1830		100,000.00

Project Description	USoA Account	Expansion or Enhancement	Amount
P00004 - Truck Replacements 1	1930		80,000.00

Project Description	USoA Account	Expansion or Enhancement	Amount
P00005 -New Connections	1830		10,000.00
	1845		14,000.00
	1840		1,000.00

Project Description	USoA Account	Expansion or Enhancement	Amount
P00006 - Smart Meters	1860		270,000.00



File Number: EB-2007-0785

Exhibit: 2

Tab: 3

Schedule: 1

Page: 3

SIOUX-LOOKOUT HYDRO INC.

Project Description	USoA Account	Expansion or Enhancement	Amount
P00007 - Tools	1940		5,000.00
	1945		3,000.00
	1955		2,000.00



SIOUX-LOOKOUT HYDRO INC.

DESCRIPTION OF CAPITAL PLAN

Including

MATERIALITY ANALYSIS ON CAPITAL ADDITIONS

Overview:

The Applicant has been, and continues to be, focused on maintaining the adequacy, reliability and quality of service to its distribution customers. The capital expenditures planned for 2008 reflect this ongoing focus. The Applicants' overall capital budget for 2008 is \$651,890, reflecting an increase of \$307,600 or 90%) over 2007. The increase can mainly be explained by the implementation of the Smart Meter Initiative in 2008.

This Overview contains:

- (a) Descriptions of certain key elements of the Applicant's 2008 capital budget, in the following categories:
 - 1. Distribution Plant
 - 2. Other Computer Hardware and Software;
 - 3. Transportation and Related Equipment; and
 - 4. Tools and Equipment

- (b) A summary of The Applicant's capital budgets for 2006, 2007 and 2008 which is detailed in Exhibit 2. Tab 3, Schedule 1.

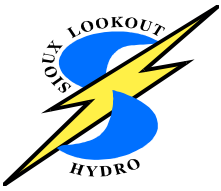
**SIOUX-LOOKOUT HYDRO INC.****KEY ELEMENTS OF THE CAPITAL BUDGET:****1. DISTRIBUTION PLANT**

The following discussion addresses various key projects within the distribution plant component of The Applicant's 2008 Capital Budget. Overall, The Applicant intends to spend a total of \$561,890 on distribution plant in 2008, on the following categories of projects:

Table 1 – Distribution Plant Capital 2006-2008 Total by Type

	Category/Year	2006	2007	2008
A.	Customer Demand	20,000	25,000	25,000
B.	Renewal	95,568	132,890	135,590
C.	Capacity	0	100,000	131,300
D.	Regulatory Requirement	0	50,000	270,000
	Total	115,568	307,890	561,890

Projects within the categories in the above table are discussed on the following pages.



SIOUX-LOOKOUT HYDRO INC.

A. Customer Demand Projects:

Total Cost \$25,000

Project Description:

Projects in this pool include installations of service wires and transformers to connect new customers to the electrical distribution system, new subdivision development, roadway relocations and upstream/enhancement projects.

Work planned for 2008 includes relocation projects requiring The Applicant to relocate its distribution plant to accommodate other utility work or municipal or provincial roadwork. Examples of such work would include road widening and closures, bridge re-builds, requests from other utilities, and customer requests for plant relocation, either temporary or permanent.

Justification:

The Applicant is obligated under the Code to connect new customer services. The replacement component is justified on the basis of the obligation to meet changing customer needs.

Relocation projects are performed primarily because third parties need plant relocated in order to do their work. Projects in this pool benefit customers by increasing reliability as permanent relocations that are built to current standards replace plant that is usually older and less reliable.



SIOUX-LOOKOUT HYDRO INC.

Table 2 – Planned 2008 Customer Demand Projects

Project	2008
New Connections	25,000
Total	<u>25,000</u>

The cost of new services collected from customers in the form of capital contributions is estimated at \$25,000.+

Of the work planned for 2008, individual projects that equal or exceed the 1% materiality threshold are listed below in Table 3. These figures are also reflected in Table 2.

Table 3 – 2008 Individual Services Projects Equaling or Exceeding the 1% materiality threshold

Description	Project Cost
	<u>(\$ 000)</u>
P00001 - Mill Line Upgrade	\$131,300
P00003 - Pole Replacement Program	\$100,000
P00004 - Truck Replacements 1	\$80,000
P00006 - Smart Meters	\$270,000
Total	<u>\$581,300</u>

The estimated requirements for new services in 2008 are based on the known customer requests as well as historical data on connections of similar services.



SIOUX-LOOKOUT HYDRO INC.

B. Renewal Projects:

Total Cost: \$135,590

Project Description:

These projects involve the replacement of deteriorated or damaged distribution structures and electrical equipment.

Renewal projects can involve either the complete rebuilding of deteriorated lines or the selective replacement of line components. Renewal decisions are based on the need to maintain the integrity, safety and reliability of the system.

Renewal projects may be done at the same voltage level or, in the case of 4.16 kV plant needing renewal, the plant may be converted to 13.8 kV or to 27.6 kV.

The work planned for 2008 includes approximately 2 rebuild projects.

Justification:

The Applicant maintains its distribution plant according to a thorough assessment that uses a combination of time based and condition based maintenance methodology. Despite performing maintenance according to developed plans, distribution assets do ultimately fail and reach a point where no reasonable amount of maintenance will improve the reliability, maintainability or safety of the equipment.

Performance statistics such as failure frequency, outage duration, and number of occurrences are recorded for distribution circuits and equipment. These statistics are used in addition to equipment inspection results, field staff feedback and engineering experience to identify needed improvement projects. At the same time, it may be economically and operationally- beneficial to change the primary voltage serving the area. Identified projects are scored against a pre-established set of criteria in categories including reliability, risk mitigation, and financial impact.

Projects in this pool, for the most part, benefit customer reliability. After a rebuild, distribution plant assets that are designed to current standards are more maintainable

**SIOUX-LOOKOUT HYDRO INC.**

and reduce safety risks to the general public and staff. In the case of rebuilds involving voltage conversion, the ultimate goal is to eliminate The Applicant owned substation equipment once all feeders are converted. The Applicant will then decommission the substation. The higher voltage distribution equipment has lower energy losses leading to cost savings. This results in a financial benefit to customers.

Expenditures:

Table 1 below summarizes the projected 2008 rebuilds and conversions expenditures

Of the work planned for 2008, individual projects that equal or exceed the 1% materiality threshold are listed in Table 4 below.

Table 4 - 2008 Individual Renewal Projects Equaling or Exceeding the 1% materiality threshold

Description	Project Cost
Hwy 72 South	35,590
Pole Replacement Program	100,000
Total	135,590

The project budget estimate is based on detailed engineering estimates of the individual project components.

Some capital projects in the rebuild and conversion project pool are multi-year projects. Generally, rebuild and conversion projects are planned within a three-year time The Applicant.



SIOUX-LOOKOUT HYDRO INC.

C. Capacity Projects:

Total Cost \$ 131,300

Project Description:

These projects consist of the construction of new feeders, equipment or conductor upgrades on existing feeders (both overhead and underground), and the installation of sections of feeders to accommodate peak demand growth. Also included is the replacement and upgrade of existing service wires and transformers due to the installation of larger wires or transformers to accommodate additional customer loads.

The work planned for 2008 consists of 1 project.

Justification:

The need to increase the capacity of the distribution system arises primarily due to load growth caused by 1) new customer connections and service upgrades; and 2) incremental growth in the demand of existing customers, and may include replacement of deteriorated equipment.

Projects in this pool represent an increase in distribution capacity that benefits many customers. They are not strictly for the benefit of single customers.

Capacity projects permit customer needs to be met in a reliable way. Available capacity is used as much as possible by periodically reconfiguring existing circuits and equipment. Only once these options have been exhausted is capacity increased. Capacity increases permit The Applicant to operate equipment within optimal rating parameters and to operate the distribution system according to accepted industry practices. This increases service reliability and allows unimpeded customer growth.

Expenditures:

New feeders and upgrades expenditures for 2008 are summarized in Table 5 below.

Table 5 - 2008 Individual Capacity Projects



SIOUX-LOOKOUT HYDRO INC.

Description	Project Cost
Mill Line Upgrade	131,300
Total	131,300

Some capital projects in the new feeders and upgrade pool are multi-year projects. Generally, new feeders and upgrades are planned within a five-year The Applicant.



SIOUX-LOOKOUT HYDRO INC.

D. Regulatory Requirement Projects:

Total Cost \$270,000

Project Description:

This project will be completed to implement the smart meter initiative.

Expenditures:

The net capital expenditure for this work is estimated to be \$947,500 over three years.



SIOUX-LOOKOUT HYDRO INC.

2. OTHER COMPUTER HARDWARE AND SOFTWARE

Computer Hardware

Computer equipment is used in all departments of utility operations and is a key enabler in The Applicant initiatives to improve reliability, improve customer service and reduce costs. SLHI has a service agreement with Thunder Bay Hydro Utility Services, where they provide us with all of our billing functions through a host computer which is maintained on their premises.

New and replacement Computer hardware consists of the following equipment:

- Desktops;
- Laptops;
- Monitors;
- Keyboards;
- Printers;
- Scanners;
- Accessories – carrying case, mouse, etc.;
- Digital cameras; and
- Disk space and memory

It is common industry practice to keep both the hardware and software environments up to date. Increased incidence of hardware failure, reduced technical support, new technical standards and higher performance requirements of current operating systems and applications drive this lifecycle.

Other benefits of replacing computer equipment and adding new equipment are:

- Reducing the dependence on IT resources to support older equipment;
- Taking advantage of new technologies and increasing server utilization;
- Empowering employees to be more productive with the right equipment to do their jobs;
- Improving access to data and other information;
- Adhering to best practices; and
- Allowing for growth

Computer Software

Total 2008 Capital Budget: \$2,000



SIOUX-LOOKOUT HYDRO INC.

Computer software, whether operating system software or application software, are programs written in machine-readable languages, that control the operations of hardware or that enable users to perform certain tasks on computers.

The operating system software controls the hardware and manages its internal functions: controls input, output and storage and, handles its interaction with application programs. Application software enables users to accomplish particular tasks.

Today, the functioning of computer software is tied closely into the hardware it resides on and it is important that the specification of any PC is appropriate for the software being installed.

Benefits of adding or replacing computer software:

- Improvements in productivity from software enhancements;
- Empowering employees with the latest software technologies;
- Keeping up to date with industry standards;
- Ease of integration to other applications;
- Reduced costs using common operating system;
- Taking advantage of higher levels of security;
- Reduced dependence on IT resources; and
- Improved tools for web development/design

Adding and replacing computer software systems is necessary to support the running of all application programs. Software provides the support necessary for computers to interact with each other. Business Applications software processes transactions that are essential to running the business.

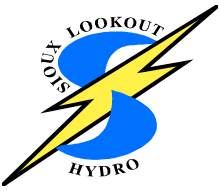

SIOUX-LOOKOUT HYDRO INC.

3. TRANSPORTATION AND RELATED EQUIPMENT

Vehicle and Related Equipment Replacement and Modification:

Total 2008 Capital Budget: \$80,000

Description:

This project provides for the replacement and modification of vehicles and equipment and tools required to outfit those vehicles, to support the construction and maintenance of the electricity distribution system for Municipality. One new vehicle body and related equipment will be purchased in 2008 to replace one aging unit.

Justification:

This project is justified based on the need to maintain vehicles and major equipment functionality and provide safe, reliable tools and equipment, driven by a strategic vehicle replacement program.

The strategic vehicle replacement program will replace aging vehicles in an even fashion avoiding sudden increases in capital acquisitions. The Applicant' historical practice has been to replace large vehicles every 8 years and small vehicles every 10 years.

The Applicant's vehicle replacement process considers the following criteria:

- Vehicle operational condition (# of repairs and cost during the previous years);
- Vehicle safety;
- Mileage & age;
- Department needs; and
- Replacement of vehicles before they become costly to repair, uneconomic and unsafe to operate.

The vehicle replacement program is based on annual condition surveys and life cycle planning. Surveys and checklists to detail problems, deficient conditions and maintenance needs are maintained as part of the vehicle preventative program.

**SIOUX-LOOKOUT HYDRO INC.**

New vehicles and equipment support productivity through innovation, improve crew response time, reduce fuel costs, lower maintenance costs, and increase environmental responsibility through fuel reduction and alternate fuel usage.

Tool and Equipment replacement supports a safe working environment, which reduces costs from lost time accidents caused by equipment failure and maintain productivity.

Projected Expenditures:

The tables below summarizes the projected 2008 fleet expenditures:

Expenditures	Number of Units	2008
Vehicles	1	\$80,000
Total		\$80,000

The table below summarizes the 2006, 2007 and 2008 fleet expenditures:

Expenditures	2006	2007	2008
Vehicles	\$0.00	\$0.00	\$80,000
Total	\$0.00	\$0.00	\$80,000

**SIOUX-LOOKOUT HYDRO INC.****4. TOOLS AND EQUIPMENT.**

Capital replacement of tools and equipment supports a safe work environment by replacing tools and equipment in a timely manner and addresses newer more ergonomically friendly tools.

Tools, Shop and Garage Equipment

	2005	2006	2007	2008**
Total	\$4,889	\$1,769	\$5,000	\$5,000

Measurement and Testing Equipment

	2005	2006	2007	2008**
Total	\$0	\$2837	\$3,000	\$3,000

Communication

	2005	2006	2007	2008**
Total	\$0	\$0.00	\$9,400	\$2,000



File Number: EB-2007-0785

Exhibit: 2

Tab: 3

Schedule: 3

Page: 1

SIOUX-LOOKOUT HYDRO INC.

SYSTEM EXPANSIONS

All projects planned are considered enhancement. The New Connections project is budgeted based on new customer connections for existing subdivision. As part of SLHI's capital contribution policy for Overhead Subdivisions, the customer pays for all poles and wires and SLHI provides funds for transformers. In the case of subdivision where the infrastructure is underground, the cost is passed along to the customer.



SIOUX-LOOKOUT HYDRO INC.

CAPITALIZATION POLICY

Projects

In the initial phase of the capital expenditure process, the President/CEO receives copies of all developer / site plan submissions to the Municipality of Sioux Lookout. He is given an opportunity to comment on the submissions and also to determine where the electrical supply should come from. The President/CEO also participates in the 5-year plan review with the Town, to be kept abreast of the major developments forecasted.

In the preparation of the annual capital expenditure plan, the President/CEO takes the above input, most of which is development related, and adds projects that it determines need to be undertaken to maintain the reliability and safety of the SLHI network, plus projects that need to be undertaken for short term and long term system improvements.

Prior to committing to a project, the President/CEO prepares a one page "Capital Project Justification" form that includes a summary of the project and a detailed estimate of the costs to be incurred. This justification form is reviewed, and if appropriate, approved by the President. The review of the project also includes a discussion of who will undertake the project. If it is determined that the project will be undertaken by Sioux Lookout staff, the President/CEO signs off on the project, committing Sioux Lookout staff to the project. If it is determined that Sioux Lookout Hydro Inc. either doesn't have the appropriate skills for the project (i.e. – construction of a substation building) or doesn't have the manpower available to undertake the project, then the project is incorporated into a Request for Proposal (RFP). Purchasing assists with the RFP processes, ensuring that only pre-qualified bidders receive the RFP and the appropriate documentation.

Upon the awarding of the contract to a bidder, the President/CEO meets with the contractor, reviews the requirements of the project and notifies Purchasing to prepare a contract.

At bi-weekly staff meetings, the President and Line Foreman review any design issues. Every three weeks the capital project scheduling and the status of uncompleted projects are reviewed. Projects are tracked manually through MS Excel, showing their current status and



SIOUX-LOOKOUT HYDRO INC.

estimated completion dates. Cost estimates are reviewed and, if required, the estimates are updated accordingly.

Many smaller projects are ongoing, and are estimated to take several years to complete. They are therefore budgeted each year, based on the portion of work expected to be completed in the following year. For major projects that will span years to complete, the practice has been to budget for the project, based on the expected expenditures for the each year.

In the past several years, Finance has taken the overall capital expenditure budget and estimated the amount of actual capital expenditures to be incurred in the following year when it prepares the cash flow budget. Finance also prepares a monthly capital expenditure report that tracks the dollars spent in the month and project-to-date against the budget dollars for that project and any revised estimates for that project.

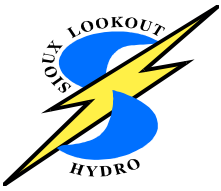

SIOUX-LOOKOUT HYDRO INC.

Vehicles

The Operations department reviews the status of all vehicles and recommend the timing for replacements. The President/CEO, sets the requirements, obtains quotes.

Other

All other capital expenditures are justified by the requesting department and approved by the appropriate level of management. Expenditures greater than \$ 10,000 requires the approval of the President. Expenditures greater than \$ 1,000 are capitalized and those less than \$ 1,000 are expensed. All capital expenditures are approved by the President/CEO.



SIOUX-LOOKOUT HYDRO INC.

WORKING CAPITAL ALLOWANCE CALCULATION BY ACCOUNT

WORKING CAPITAL ALLOWANCE CALCULATION BY ACCOUNT		2006 Actual	Allowance for Working Capital	2007 Bridge	Allowance for Working Capital	2008 Test	Allowance for Working Capital
Operation (Working Capital)							
5005	5005-Operation Supervision and Engineering						
5010	5010-Load Dispatching						
5012	5012-Station Buildings and Fixtures Expense						
5014	5014-Transformer Station Equipment - Operation Labour						
5015	5015-Transformer Station Equipment - Operation Supplies and Expenses						
5016	5016-Distribution Station Equipment - Operation Labour						
5017	5017-Distribution Station Equipment - Operation Supplies and Expenses						
5020	5020-Overhead Distribution Lines and Feeders - Operation Labour	250,187.00	37,528.05	296,282.00	44,442.30	305,170.00	45,775.50
5025	5025-Overhead Distribution Lines & Feeders - Operation Supplies and Expenses	63,801.00	9,570.15	68,500.00	10,275.00	77,500.00	11,625.00
5030	5030-Overhead Sub transmission Feeders - Operation						
5035	5035-Overhead Distribution Transformers- Operation			15,157.00	2,273.55	20,157.00	3,023.55
5040	5040-Underground Distribution Lines and Feeders - Operation Labour						
5045	5045-Underground Distribution Lines & Feeders - Operation Supplies & Expenses						
5050	5050-Underground Sub transmission Feeders - Operation						
5055	5055-Underground Distribution Transformers - Operation						
5060	5060-Street Lighting and Signal System Expense						
5065	5065-Meter Expense	3,862.00	579.30	7,500.00	1,125.00	10,000.00	1,500.00
5070	5070-Customer Premises - Operation Labour						
5075	5075-Customer Premises - Materials and Expenses						
5085	5085-Miscellaneous Distribution Expense	19,861.00	2,979.15	15,000.00	2,250.00	9,000.00	1,350.00
5090	5090-Underground Distribution Lines and Feeders - Rental Paid						
5095	5095-Overhead Distribution Lines and Feeders - Rental Paid						
5096	5096-Other Rent						
	Sub-Total	337,711.00	50,656.65	402,439.00	60,365.85	421,827.00	63,274.05
Maintenance (Working Capital)							
Main							
5105	5105-Maintenance Supervision and Engineering						



SIOUX-LOOKOUT HYDRO INC.

WORKING CAPITAL ALLOWANCE CALCULATION BY ACCOUNT		2006 Actual	Allowance for Working Capital	2007 Bridge	Allowance for Working Capital	2008 Test	Allowance for Working Capital
5110	5110-Maintenance of Buildings and Fixtures - Distribution Stations						
5112	5112-Maintenance of Transformer Station Equipment						
5114	5114-Maintenance of Distribution Station Equipment						
5120	5120-Maintenance of Poles, Towers and Fixtures	38,479.00	5,771.85	25,745.00	3,861.75	26,517.00	3,977.55
5125	5125-Maintenance of Overhead Conductors and Devices						
5130	5130-Maintenance of Overhead Services						
5135	5135-Overhead Distribution Lines and Feeders - Right of Way	39,419.00	5,912.85	45,000.00	6,750.00	40,000.00	6,000.00
5145	5145-Maintenance of Underground Conduit						
5150	5150-Maintenance of Underground Conductors and Devices						
5155	5155-Maintenance of Underground Services						
5160	5160-Maintenance of Line Transformers	1,463.00	219.45	9,414.00	1,412.10	10,000.00	1,500.00
5165	5165-Maintenance of Street Lighting and Signal Systems						
5170	5170-Sentinel Lights - Labour	10,458.00	1,568.70	2,305.00	345.75	2,374.00	356.10
5172	5172-Sentinel Lights - Materials and Expenses	2,979.00	446.85	2,000.00	300.00	2,000.00	300.00
5175	5175-Maintenance of Meters	-	-	6,291.00	943.65	6,390.00	958.50
5178	5178-Customer Installations Expenses- Leased Property						
5185	5185-Water Heater Rentals - Labour						
5186	5186-Water Heater Rentals - Materials and Expenses						
5190	5190-Water Heater Controls - Labour						
5192	5192-Water Heater Controls - Materials and Expenses						
5195	5195-Maintenance of Other Installations on Customer Premises						
	Sub-Total	92,798.00	13,919.70	90,755.00	13,613.25	87,281.00	13,092.15
Billing and Collections							
5305	5305-Supervision						
5310	5310-Meter Reading Expense	58,768.00	8,815.20	78,473.00	11,770.95	80,658.00	12,098.70
5315	5315-Customer Billing	115,441.00	17,316.15	159,403.00	23,910.45	179,865.00	26,979.75
5320	5320-Collecting	68,810.00	10,321.50	69,641.00	10,446.15	86,006.00	12,900.90
5325	5325-Collecting- Cash Over and Short	(819.00)	(122.85)	(3.00)	(0.45)	(3.00)	(0.45)
5330	5330-Collection Charges	23,619.00	3,542.85	300.00	45.00	300.00	45.00
5335	5335-Bad Debt Expense	(44.00)	(6.60)	40,000.00	6,000.00	20,000.00	3,000.00



SIOUX-LOOKOUT HYDRO INC.

WORKING CAPITAL ALLOWANCE CALCULATION BY ACCOUNT		2006 Actual	Allowance for Working Capital	2007 Bridge	Allowance for Working Capital	2008 Test	Allowance for Working Capital
5340	5340-Miscellaneous Customer Accounts Expenses						
Sub-	Sub-Total	265,775.00	39,866.25	347,814.00	52,172.10	366,826.00	55,023.90
Community Relations							
5405	5405-Supervision						
5410	5410-Community Relations - Sundry						
5415	5415-Energy Conservation						
5420	5420-Community Safety Program						
5425	5425-Miscellaneous Customer Service and Informational Expenses						
5505	5505-Supervision						
5510	5510-Demonstrating and Selling Expense						
5515	5515-Advertising Expense						
5520	5520-Miscellaneous Sales Expense						
Sub-	Sub-Total	-					
Administrative and General Expenses							
5605	5605-Executive Salaries and Expenses	34,890.00	5,233.50	17,500.00	2,625.00	18,500.00	2,775.00
5610	5610-Management Salaries and Expenses	82,024.00	12,303.60	77,565.00	11,634.75	79,807.00	11,971.05
5615	5615-General Administrative Salaries and Expenses	25,459.00	3,818.85	39,560.00	5,934.00	40,552.00	6,082.80
5620	5620-Office Supplies and Expenses	8,669.00	1,300.35	8,300.00	1,245.00	8,600.00	1,290.00
5625	5625-Administrative Expense Transferred Credit						
5630	5630-Outside Services Employed	16,278.00	2,441.70	27,683.00	4,152.45	30,683.00	4,602.45
5635	5635-Property Insurance	25,468.00	3,820.20	26,176.00	3,926.40	26,700.00	4,005.00
5640	5640-Injuries and Damages						
5645	5645-Employee Pensions and Benefits						
5650	5650-Franchise Requirements						
5655	5655-Regulatory Expenses	6,221.00	933.15	38,000.00	5,700.00	13,000.00	1,950.00
5660	5660-General Advertising Expenses	785.00	117.75	800.00	120.00	1,000.00	150.00
5665	5665-Miscellaneous General Expenses	28,085.00	4,212.75	23,515.00	3,527.25	20,815.00	3,122.25
5670	5670-Rent	14,966.00	2,244.90	17,000.00	2,550.00	19,050.00	2,857.50
5675	5675-Maintenance of General Plant						



SIOUX-LOOKOUT HYDRO INC.

WORKING CAPITAL ALLOWANCE CALCULATION BY ACCOUNT		2006 Actual	Allowance for Working Capital	2007 Bridge	Allowance for Working Capital	2008 Test	Allowance for Working Capital
5680	5680-Electrical Safety Authority Fees	910.00	136.50	2,185.00	327.75	2,185.00	327.75
5685	5685-Independent Market Operator Fees and Penalties						
Sub-Total		243,755.00	36,563.25	278,284.00	41,742.60	260,892.00	39,133.80
Taxes Other Than Income Taxes							
6105	6105-Taxes Other Than Income Taxes	7,466.00	1,119.90	8,700.00	1,305.00	8,700.00	1,305.00
Sub-Total		7,466.00	1,119.90	8,700.00	1,305.00	8,700.00	1,305.00
Cost of Power							
4705	4705-Power Purchased	5,139,769.00	770,965.35	6,149,927.00	922,489.05	6,466,924.00	970,038.60
4708	4708-Charges-WMS	516,585.00	77,487.75	668,469.00	100,270.35	702,927.00	105,439.05
4714	4714-Charges-NW	482,499.00	72,374.85	569,058.00	85,358.70	597,037.00	89,555.55
4716	4716-Charges-CN	138,197.00	20,729.55	488,473.00	73,270.95	511,895.00	76,784.25
4730	4730-Rural Rate Assistance Expense	-	-	-	-	-	-
4750	4750-Charges LV	339,143.00	50,871.45	340,000.00	51,000.00	340,456.00	51,068.40
Sub-Total		6,616,193.00	992,428.95	8,215,927.00	1,232,389.05	8,619,239.00	1,292,885.85
WORKING CAPITAL ALLOWANCE TOTAL		7,563,698.00	1,134,554.70	9,343,919.00	1,401,587.85	9,764,765.00	1,464,714.75



File Number: EB-2007-0785

Exhibit: 2

Tab: 4

Schedule: 1

Page: 1

SIOUX-LOOKOUT HYDRO INC.



SIOUX LOOKOUT HYDRO INC.

<u>Ex.</u>	<u>Tab</u>	<u>Schedule</u>	<u>Contents of Schedule</u>
<u>3 - Distribution Revenue</u>			
		1	Overview of Distribution Revenue
		2	Summary of Distribution Revenue Table
		3	Variance Analysis on Distribution Revenue
		2	Throughput Revenue
		1	Weather Normalized Forecasting Methodology
		2	Population Change in Northern Ontario - 2006 Census Research Study
		3	Normalized Volume Forecast Table
		4	Customer Count Forecast Table
		5	Historical Average Consumption
		3	Other Revenue
		1	Other Distribution Revenue
		2	Materiality Analysis on Other Distribution Revenue
		3	Rate of Return on Other Distribution Revenue
		4	Distribution Revenue Data
		4	Revenue Sharing
		1	Description of Revenue Sharing



SIOUX-LOOKOUT HYDRO INC.

OVERVIEW OF DISTRIBUTION REVENUE

This exhibit provides the details on the Applicant's Distribution Revenues for Historical, Historical Board Approved, Bridge year and Test years. This exhibit also provides a detailed variance analysis by rate class of the Distribution Revenue components.

Distribution revenues have been calculated using the most recently approved rates. Specifically delivery rates approved in RP-2007-0576 Rate Order, dated April 12, 2007. A summary of normalized Distribution Revenues is presented in Exhibit 3, Tab 1, Schedule 2.

Throughput Revenue

Information related to the utility's throughput revenue include details such as weather normalized forecasting methodology, normalized volume and customer counts forecast tables.

Other Revenue

Other revenues include revenues such as Late Payment Charges, Miscellaneous Service Revenues and Retail Services Revenues. A summary of these Distribution Revenues is presented in Exhibit 3, Tab 3, Schedule 1.



SIOUX-LOOKOUT HYDRO INC.

SUMMARY OF DISTRIBUTION REVENUE TABLE

SUMMARY OF DISTRIBUTION REVENUE TABLE	2006 Board Approved	2006 Actual	Variance form 2006 Board Approved	2006 Actual	2007 Bridge	Variance form 2006 Actual	2007 Bridge	2008 Test	Variance form 2007 Actual
	(\$'s)	(\$'s)	(\$'s)	(\$'s)	(\$'s)	(\$'s)	(\$'s)	(\$'s)	(\$'s)
<u>Distribution Revenues</u>									
Residential	832,450.80	825,049.76	(7,401.04)	825,049.76	849,929.73	24,879.97	849,929.73	1,093,936.45	244,006.72
GS < 50 kW	305,307.54	271,261.66	(34,045.87)	271,261.66	273,830.75	2,569.09	273,830.75	355,192.17	81,361.42
GS Interval Meters >50 - 5000 kW	330,323.26	396,387.91	66,064.65	396,387.91	447,563.68	51,175.77	447,563.68	687,391.41	239,827.72
Street Lighting	8,918.70	8,852.26	(66.43)	8,852.26	8,928.07	75.80	8,928.07	11,651.33	2,723.27
USL	2,751.43	2,713.16	(38.27)	2,713.16	2,746.11	32.95	2,746.11	3,227.07	480.96
	1,479,751.73	1,504,264.75	24,513.03	1,504,264.75	1,582,998.34	78,733.58	1,582,998.34	2,151,398.43	568,400.09
<u>Other Distribution Revenue</u>									
4225-Late Payment Charges	50,517.00	54,829.00	4312.00	54,829.00	54,000.00	3,483.00	54,000.00	54,000.00	-
4235-Miscellaneous Service Revenues	50,231.00	20,122.00	(30,109.00)	20,122.00	20,122.00	-	20,122.00	20,122.00	-
4210-Rent from Electric Property	16,367.00	42,027.00	25,660.00	42,027.00	42,027.00	-	42,027.00	42,027.00	-
4390-Miscellaneous Non-Operating Income	9,864.00	13,404.00	3,540.00	13,404.00	13,404.00	-	13,404.00	13,404.00	-
4405-Income from Dividend	25,311.00	43,017.00	17,706.00	43,017.00	43,000.00	(17.00)	43,000.00	45,000.00	2,000.00
4360-Loss on Disposition of Utility and Other Property	(3,329.00)	(825.00)	2,504.00	(825.00)	(825.00)	-	(825.00)	(825.00)	-
	148,961.00	172,574.00	23,613.00	172,574.00	171,728.00	3,466.00	171,728.00	173,728.00	2,000.00



SIOUX-LOOKOUT HYDRO INC.

VARIANCE ANALYSIS ON DISTRIBUTION REVENUE

2008 Test Year

SLHI's total Distribution Revenue including Other Distribution Revenues is forecast to be \$2,325,126 for Fiscal 2008, as shown in Exhibit 3, Tab 3, Schedule 2. Distribution revenue totals \$2,151,398 or 92% of total revenues. Other Distribution Revenues (net) account for the remaining revenue of \$173,728

Comparison to 2007 Bridge Year

As shown in Exhibit 3, Tab 1, Schedule 2, the total Distribution Revenue is expected to be \$569,400 or 36% above the bridge year level in fiscal 2007.

2007 Bridge Year

SLHI's total Distribution Revenue is forecast to be \$1,754,726 for Bridge 2007, as shown in Exhibit 3, Tab 1, Schedule 2. Distribution revenue totals \$1,582,998 or 90% of total revenues. Other Distribution Revenues (net) account for the remaining revenue of \$171,728

Comparison to Fiscal 2006 Actual

As shown in Exhibit 3, Tab 1, Schedule 2, the Distribution Revenue is expected to be \$78,733 or 5% above the bridge year level in actual 2006.

2006 Actual

SLHI total Distribution Revenue for 2006 actual was \$1,676,838, as shown in Exhibit 3, Tab 1, Schedule 2. Distribution revenue totals \$1,504,264 or 89.7% of total revenues. Other Distribution Revenues (net) account for the remaining revenue of \$172,574.

Comparison to 2006 Board Approved

As shown in Exhibit 3, Tab 1, Schedule 2, the total Distribution Revenue was \$24,513 above the bridge year level in actual 2006.

2006 Board Approved



File Number: EB-2007-0785

Exhibit: 3

Tab: 1

Schedule: 3

Page: 2

SIoux-LOOKOUT HYDRO INC.

SLHI total Distribution Revenue for 2006 Board Approved was \$1,628,712, as shown in Exhibit 3, Tab 1, Schedule 2. Distribution revenue totals \$1,479,751 or 90.8% of total revenues. Other Distribution Revenues (net) account for the remaining revenue of \$148,961.



SIOUX-LOOKOUT HYDRO INC.

WEATHER NORMALIZED FORECASTING METHODOLOGY

This exhibit discusses the methodology used to determine The Applicant's customer and load forecast. A projection for the number of customers in each customer class is provided for both the Bridge Year (2007) and the Test Year (2008). Historical data for the annual number of customers in each rate class is available for 2002 through to 2006. As a result of the limited amount of data available for the period prior to 2002, time series techniques that are often used to help estimate forecast values cannot be used. Rather, the Applicant has used a simple trend growth in customer connections, by class, to forecast Bridge and Test Year customer numbers. Given the slow growth and consistent trend in customer numbers in The Applicant's service territory over the past five years, the resulting customer forecast is likely not materially different than what would result from using more sophisticated time series techniques. In recent history, there has been very little year-to-year variation in customer growth by class. Historical and forecast customer numbers, by class, are displayed in the next section.

As required by the OEB Filing Requirements for Transmission and Distribution Applications, we are providing normalized historical and forecast (Bridge Year and Test Year) throughput data. Weather normalization (where required) is based on normalized average use per customer ("NAC") calculated from the weather-normalized throughput of the utility from 2004. This weather-normalized throughput was generated by Hydro One using their weather normalization model for the Cost Allocation process previously undertaken by the Board. The process to obtain these weather normal data was an intensive effort for all parties involved, and we are leveraging the value of this work by using it for this process.

The change in trend in 2005 to 2006 is due to the reclassifying of certain customer to the GS > 50 class. Following a review of the customer usages, customer averaging over 50 KW demand a month were moved to their appropriate class.

Customer Forecast



SIOUX-LOOKOUT HYDRO INC.

Table 1 below presents historical and forecast customer numbers, by class, for The Applicant.

							Bridge Year Estimate	Bridge Year Normalized	Test Year
		2002	2003	2004	2005	2006	2007	2007	2008
RESIDENTIAL									
Regular		2,279	2,274	2,287	2,300	2,293	2,297	2,297	2,301
			<i>0.9978</i>	<i>1.0057</i>	<i>1.0057</i>	<i>0.9970</i>		<i>0.15%</i>	
GENERAL SERVICE									
Less than 50 kW		423	417	414	423	399	399	399	399
	% increase		<i>0.9858</i>	<i>0.9928</i>	<i>1.0217</i>	<i>0.9433</i>		<i>-2.63%</i>	
GS > 50 kW (to 3000 kW)		27	32	35	37	42	42	42	43
	% increase		<i>1.1852</i>	<i>1.0938</i>	<i>1.0571</i>	<i>1.1351</i>		<i>11.68%</i>	
Street Lighting		535	535	537	532	533	533	533	533
	% increase		<i>0.00%</i>	<i>0.37%</i>	<i>-0.93%</i>	<i>0.19%</i>		<i>-0.09%</i>	
USL		10	12	12	12	12	12	12	12
	% increase		<i>1.2000</i>	<i>1.0000</i>	<i>1.0000</i>	<i>1.0000</i>			

Annual percentage change is presented in red for Residential, GS<50, and GS 50-3000 classes. For all three classes, the blue highlighted percentage change for 2007 represents the annual average geometric mean growth rate for 2002 to 2006.

Being a relatively small utility SLHI was able to project its own customer growth for 2007 and 2008. The applicant does not foresee a significant growth in the number of customer in the General Service classes and therefore the volume forecast and largely reflects the customer growth rate. The 2006 Census Research Paper Series – Population Change in Northern Ontario by Chris Southcott, Ph.D. Lakehead University, included at Exhibit 3, Tab 2, Schedule 2 provides insight on demographic trends in the Northern Ontario including the Municipality of Sioux-Lookout.



SIOUX-LOOKOUT HYDRO INC.

Customer numbers for Lighting, Street Lighting, and USL classes in 2007 also represent current (early 2007) number of connections in each of these classes. The Applicant does not expect the number of customers in the and USL classes to change within the next year and the 2007 current figures are used for 2008. Customer growth for the Street Lighting Class is calculated based on the annual average geometric mean of growth from 2002 to current year (2007) once again SLHI projected their own customer growth for 2007 and 2008.

The figures below illustrate the historical and forecast customer trend in Residential, GS<50, and GS>50 to 3000classes

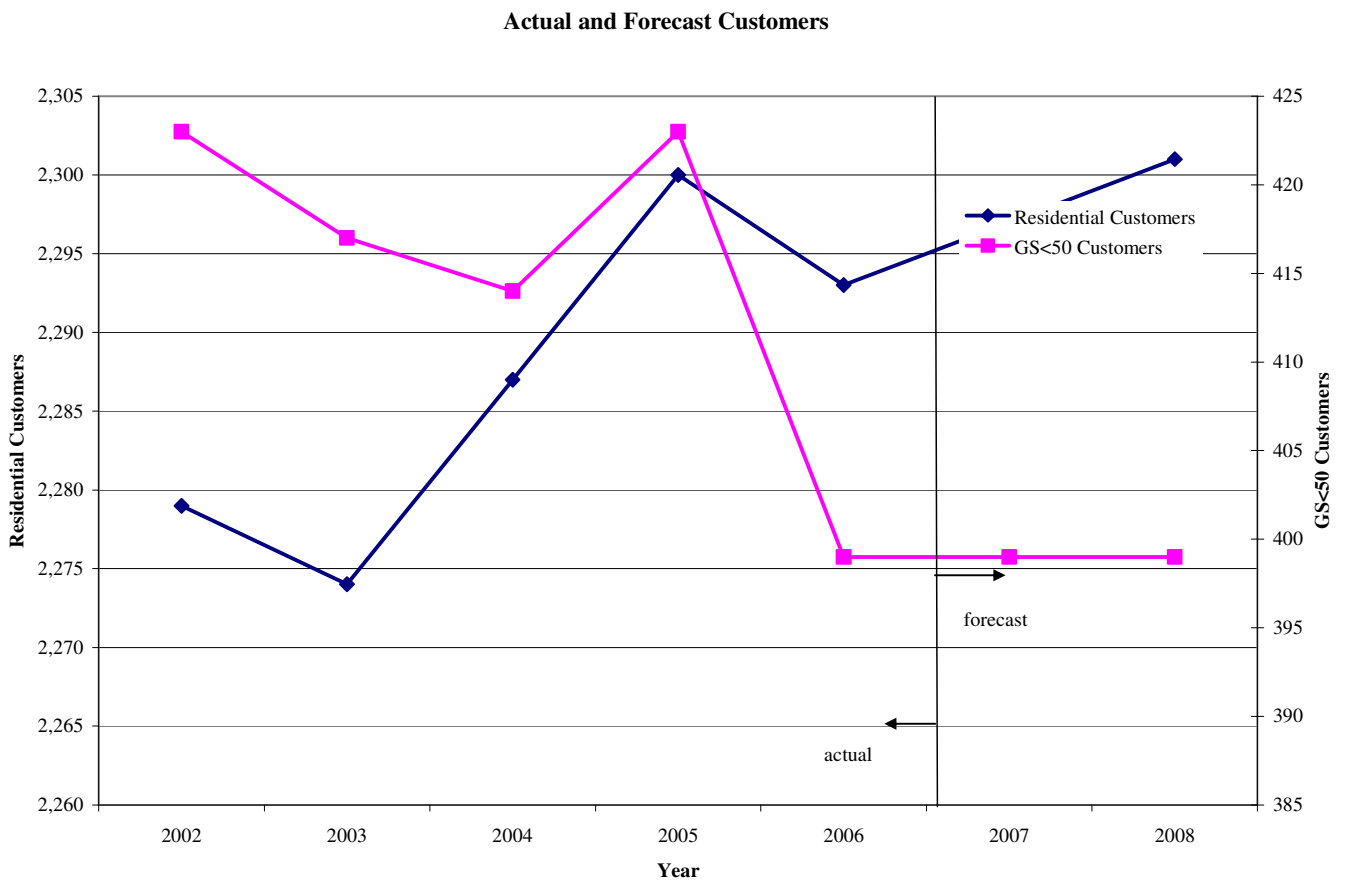



SIOUX-LOOKOUT HYDRO INC.

Actual and Forecast Customers

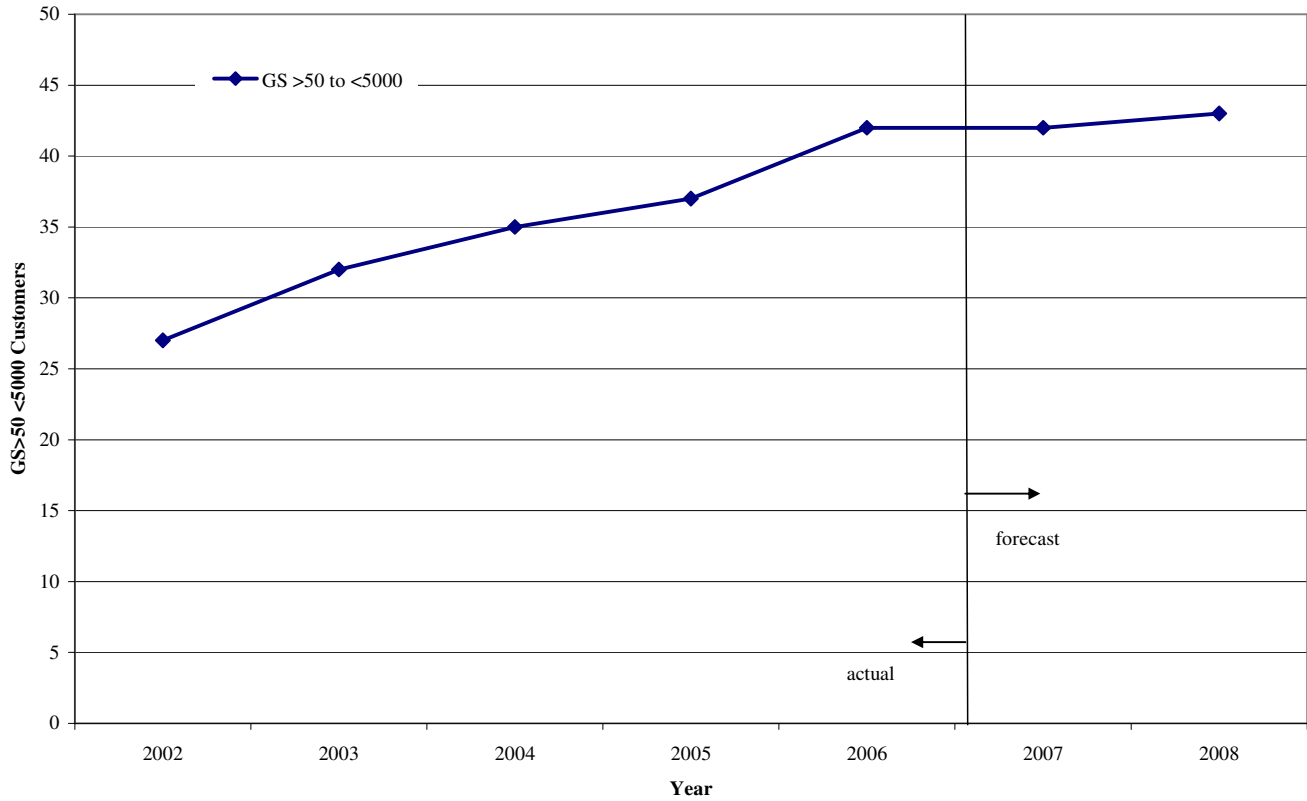

Several classes are billed based on demand charges (GS>50, LU, Street Lighting) and require an estimate of billed kW. Billed kW is estimated based on a load factor calculated using a ratio of historical billed kW to historical retail kWh, by class. The following table summarizes the results of The Applicant's customer and load forecast.



SIOUX-LOOKOUT HYDRO INC.

Sioux Lookout Hydro		Historical Actual	Historical Board Approved	Historical Actual Normalized	Bridge Year -Est.	Bridge Year Estimate Normalized	Test Year Normalized Forecast
Year		2006	2004	2006	2007	2007	2008
Customer Class							
Residential	Customers	2,293	2,287	2,293	2,297	2,297	2,301
	Consumption - kWh	31,452,628	32,478,156	33,318,949	31,507,495	33,377,072	33,435,195
GS < 50 kW	Customers	399	414	399	399	399	399
	Consumption - kWh	14,960,770	19,083,747	15,941,009	14,960,770	15,941,009	15,941,009
GS Interval Meters >50 - 5000 kW	Customers	42	35	42	42	42	43
	Consumption - kWh	45,150,837	41,418,697	47,204,514	45,150,837	47,204,514	48,328,431
	Demand - KW	106,738	110,498	111,593	113,106	118,251	121,066
Street Lighting	Connections	533	537	533	533	533	533
	Consumption - kWh	488,766	465,217	488,766	488,766	478,103	477,656
	Demand - KW	1,449	1,475	1,449	1,510	1,477	1,475
USL	Customers	12	12	12	12	12	12
	Consumption - kWh	24,781	30,761	24,781	24,781	24,781	24,781

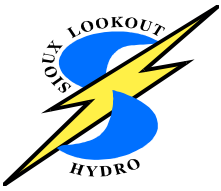

SIOUX-LOOKOUT HYDRO INC.

**2006 Census
2006 Research
2006 Paper
2006 Series**



**Population
Change
in Northern
Ontario
2001 to
2006**



File Number: EB-2007-0785

Exhibit: 3

Tab: 2

Schedule: 2

Page: 2

SIOUX-LOOKOUT HYDRO INC.

by **Chris
Southcott,
Ph.D.
Lakehead
University**

Prepared for the Training Boards of Northern Ontario

A *Algoma Workforce*



File Number: EB-2007-0785

Exhibit: 3

Tab: 2

Schedule: 2

Page: 3

SIOUX-LOOKOUT HYDRO INC.

Far Northeast
Training Board



File Number: EB-2007-0785

Exhibit: 3

Tab: 2

Schedule: 2

Page: 4

SIOUX-LOOKOUT HYDRO INC.

WI

Investment Committee



SIoux-LOOKOUT HYDRO INC.

EXECUTIVE SUMMARY

Background to the Report:

This study has been prepared for the 5 existing Local Training and Adjustment Boards in Northern Ontario. Due to the particular economic conditions in Northern Ontario, it is very important for the Northern Boards to properly understand the demographic trends occurring in their region. This is the first research report in a series that examines the current trends in

Northern Ontario using data from the 2006 Census. Based on concerns expressed in the Trends, Opportunities, and Priorities (TOPS) Reports, this report attempts to measure the extent of population change in Northern Ontario.

Methodology:

This report is based on newly released data from the 2006 Census as prepared by Statistics Canada. Data is also used from other Census years as compiled by Statistics Canada.

Findings:

Based on analysis of 2006 Census data on population, there appears to be six main population trends occurring in Northern Ontario.

1. The first is that the population has stabilized. Statistically speaking the population of Northern Ontario was virtually the same in 2006 as it was in 2001.
2. Northern Ontario is still shrinking as a percentage of the population of Ontario. In 2001 Northern Ontario represented 6.9% of the total population of Ontario. By 2006 this percentage was down to under 6.5%.
3. High growth rates in most Aboriginal communities in Northern Ontario show these communities continue to be the most dynamic in the region. Average growth rates for these communities increased to 16.5%.
4. Another noticeable trend is a return of growth to the largest urban centres. The urban areas of North Bay, Sudbury, Sault Ste. Marie, and Thunder Bay all saw



SIOUX-LOOKOUT HYDRO INC.

their population grow during this period.

5. Population figures also indicate mining dependent communities were better off than

forest dependent communities. While there were exceptions, several mining

communities across saw growth from 2001 to 2006 while many forest dependent

communities continued to experience similar declines.

6. Those communities that are closest to the urban centres of Southern Ontario tended to

have growth as opposed to decline.



SIOUX-LOOKOUT HYDRO INC.

Section One: Introduction

1.1 Background to the Report

This study has been prepared for the 6 Local Training and Adjustment Boards in Northern Ontario. The Muscodia, Nipissing, Parry Sound Local Training and Adjustment Board (Board #20), the Sudbury and Manitoulin Training and Adjustment Board (Board #21), the Algoma Training Board (Board #22), the Far Northeast Training Board (Board #23), the North Superior Training Board (Board #24) and the Northwest Training and Adjustment Board (Board #25) are among the 25 Local Training and Adjustment Boards established in Ontario in 1994.¹ These Boards were created to assist in assessing the training needs and issues of each area. Each Board is made up of representatives of the key labour market partner groups including primarily business and labour but also including educators and trainers, women, persons with disabilities, francophones, and racial minorities. The Boards also have non-voting representatives from the municipal, provincial, and federal governments. The Boards are sponsored by Human Resources and Development Canada and the Ontario Ministry of Training, Colleges and Universities.

The 2001 Census Research Series produced by the Northern Boards from 2002 to 2004 showed that Northern Ontario is a region undergoing important transformations. Economic growth in Northern Ontario has been significantly less than the provincial average since the 1970s. Since training is seen as an important development tool by most people in the region, regional Boards



SIOUX-LOOKOUT HYDRO INC.

are therefore necessarily involved in economic development discussions. Population trends are an indicator of economic development. These trends also have an important impact on future development decisions. It, therefore, becomes very important for the Training Boards of Northern Ontario to understand what population trends exist in their region.

The present study attempts to compare population trends identified in the 2001 Census Research Series population report.² That report identified four main population trends occurring between 1996 and 2001. The most important trend was a general decline in population. It occurred in the major urban areas of the region as well as the non-Aboriginal resource dependent communities of the region. Pulp and paper towns, sawmill towns, and mining towns all decreased in size although the extent of the decrease varied from community to community. The next trend was relatively high rates of growth due to natural increase in the Aboriginal communities of the region. Overall, the average rate of growth for these communities was 5.9% in Northern Ontario. While this growth rate was slightly less than the 6.1% growth rate for Ontario, it was substantially higher than the 4% growth rate for Canada. Another trend was a slow increase in the Acottage country@ communities closest to the major urban areas of Southern Ontario. This was clearly seen in the Muskoka District Municipality but also in some communities in the District of Parry Sound. Finally, some growth was seen in the suburban areas surrounding the largest urban centres of Northern Ontario. Those townships with lakefront appeared to have the most growth

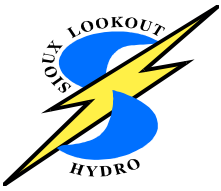

SIOUX-LOOKOUT HYDRO INC.

Section Two: Background to Population Change in Northern Ontario

2.1 Introduction to Northern Ontario

Northern Ontario comprises more than 88% of the land mass of Ontario but represents only 6.5% of the total population of the province (2006 Census). This percentage represents a decrease from 6.9% in 2001. As the region has no legislated boundaries, the definition of the region varies, especially as concerns its southern border. Currently, for the purpose of programming and statistical analysis, the provincial government has defined Northern Ontario as comprising the Regional Municipality of Greater Sudbury and the following districts: Kenora, Rainy River, Thunder Bay, Algoma, Cochrane, Manitoulin, Sudbury, Timiskaming, Nipissing, and Parry Sound. In 2000, the Ontario government decided to also include the Muskoka District Municipality in its definition of Northern Ontario. This inclusion was somewhat problematic in that the socio-economic characteristics of the Muskoka District Municipality differ from that of the other Districts in Northern Ontario. In 2004 the government changed the definition to once again exclude the Muskoka District Municipality. For the purposes of FedNor programming, the federal government continues to include the Muskoka District Municipality in its operational definition of Northern Ontario. In the 2001 Census Research Series, the Muskoka District Municipality was included in statistics relating to Northern Ontario. Due to the recent change in definition by the provincial government, 2006 based reports will exclude the



SIOUX-LOOKOUT HYDRO INC.

Muskoka District Municipality from statistics relating to Northern Ontario. Comparisons between the data presented in the previous reports need to take this change in definition into account. The Muskoka district will however be included in statistics related to Muskoka, Nipissing, Parry Sound Local Training and Adjustment Board (Board #20).

The history of continuous settlement by non-Natives in Northern Ontario is relatively recent when compared to the rest of Ontario. Settlement in earnest started with the construction of the Canadian Pacific Railway in the late 1870s and 1880s. This was soon followed by the construction of the Canadian Northern Railway and the Grand Trunk and National Transcontinental Railways. Most non-Native communities in the region were initially railway towns.

Following the building of the railways, the region=s growth has been driven primarily by the forest industry and by mining. The development of communities was, for the most part, undertaken by large resource extraction corporations based outside the region rather than by local entrepreneurs. This fact has meant that the social and economic structure of this region exhibits several unique characteristics.³

The first of these characteristics relates to an overdependence on natural resource exploitation. This has meant a high degree of vulnerability to resource depletion, world commodity prices, corporate policy changes, the boom and bust cycles of the resource industries, changes in the



SIOUX-LOOKOUT HYDRO INC.

Canadian exchange rate, and changes in government policies regarding Northern Ontario.⁴

The second characteristic is a high degree of dependency on external forces. The fact that most communities were developed by outside forces means that local entrepreneurship has been more limited than in other areas. This has served as a barrier to the cultivation of an entrepreneurial culture in these communities. This dependence is also seen in the area of political decision-making. Unlike most areas of Ontario, Northern Ontario is made up of Districts instead of Counties. Unlike Counties, Districts do not have regional governments. Northern Ontario is unique in Ontario in that unlike the Counties of Southern Ontario there is no regional government serving as an intermediary between the provincial government and municipalities.⁵

While all communities in the region share some common characteristics, Northern Ontario can be divided internally into three different types of communities:

Small and Medium-sized cities - Northern Ontario includes 5 cities with over 40,000 inhabitants. They are, in order of size, Sudbury (157,857), Thunder Bay (109,140), Sault Ste. Marie (74,948), North Bay (53,966), and Timmins (42,997).⁶ While these centres are heavily dependent on resource industries they are also relatively diversified in that they tend to be important centers for health, education, and other services for the outlying regions.

Resource Dependent Communities - The vast majority of the remaining non-Native communities in the region are resource dependent communities, or single industry towns, which share many distinct characteristics.⁷ These communities are smaller and less diversified economically than



SIOUX-LOOKOUT HYDRO INC.

the small and medium-sized cities. They are much more directly dependent on resource industries.

First Nations Communities - The region of Northern Ontario is unique in terms of its large number of Aboriginal communities. The Aboriginal population makes up almost 8 percent of the population of the region.⁸ The population in the area of the region north of the 50th parallel is almost entirely made up of these communities. First Nations communities face the greatest number of social and economic challenges of all the communities in the region.

2.2 Socio-Economic Trends Identified in Previous Trends, Opportunities, and Priorities (TOPS) Reports

As part of their planning process the Boards are mandated to produce a Trends, Opportunities, and Priorities (TOPS) Report for their particular area every year. A TOPS report is just one aspect of a broader framework of activities undertaken by the Boards each year. It forms the basis for the Local Boards' planning processes and enables the Boards to engage the community in helping to identify and act upon training and adjustment needs.

TOPS reports produced by the Boards since 2004 have indicated the following trends in the



SIOUX-LOOKOUT HYDRO INC.

region:⁹

- a slow but constant regional population decline
- a slow but increasing aging of the population when compared to Ontario - high rates of youth out-migration
- a dependence on natural resource exploitation industries and a lack of secondary industries - lower education and literacy levels when compared to Ontario
- high levels of unemployment
- shortages in trades, healthcare, and technology occupations - low levels of in-migration and few recent immigrants
- recent declines in the forest industry
- lower levels of participation rates for women in the labour force - growth of a regional aboriginal labour force

Section Three: Methodology

This report attempts to describe the current situation of population changes in Northern Ontario. It will compare trends from 2001 to 2006 to those found in the 2001 Census Research reports and to trends identified in the TOPS reports. This report is based on newly released data from the 2006 Census as prepared by Statistics Canada. Data is also used from other Census years as compiled by Statistics Canada.

Data for Northern Ontario from both the 1996, 2001 and 2006 Census is from special profiles ordered from Statistics Canada by the researcher. Data from the 1991 and 1986 Census was downloaded from the Census Profiles CDs created by Statistics Canada. Data from the 1981, 1976, and 1971 Census were copied from the print versions of census profiles of communities in Ontario prepared by Statistics Canada.

3.1 Potential problems with our method



SIOUX-LOOKOUT HYDRO INC.

Our method has two potential problems which must be mentioned: the “random rounding” technique used by Statistics Canada, and problems with data for Aboriginal communities in Northern Ontario. Sampling error is not a serious issue with the data being used because population data, in theory, covers 100% of households.¹⁰

The first potential problem is the use of random rounding by Statistics Canada in its census data.¹¹ In order to ensure confidentiality, census data is round up or down to the nearest 5 count. This has an insignificant effect on large numbers. On very small numbers however this process can introduce a significant degree of error. This limits our ability to be confident about the exact number of people for very small communities in Northern Ontario.

The other problem is related to the counting, or non-counting, of Aboriginal communities.¹² The



SIoux-LOOKOUT HYDRO INC.

population figures for the census divisions in Northern Ontario are not as reliable as the census divisions in most of Ontario. This is due to the large number of Aboriginal communities which, for various reasons, are improperly counted. If Statistics Canada can not properly count a community, the population of that community is not included in the population totals for that census division. As a result, in past censuses, the population figures for almost all the census divisions in Northern Ontario are incomplete. Another problem which arises is comparing these figures from census year to census year. In 2001, Statistics Canada was much more successful in counting the populations of the Aboriginal communities in Northern Ontario than they were in 1996. As a result, many more communities were included in the 2001 Census that were excluded in the 1996 Census. This makes it difficult to compare the figures for 2001 and 1996.

The same is true for comparisons of figures from the 2006 census. Data for Northern Ontario shows only one community that was not counted in either 2006 or 2001, Bear Island 1 in the District of Nipissing. Seven additional communities with population were counted in the 2006 Census but not the 2001 Census: Goulais Bay 15A and Rankin Location 15D in the District of Algoma; Ojibway Nation of Saugeen (Savant Lake) and Whitesand in the District of Thunder Bay; and Marten Falls 65, Pikangikum 14, and Whitefish Bay 32A in the District of Kenora. Three communities were counted in 2001 but not in 2006: Factory Island 1 in the District of Cochrane, and Attawapiskat 91A and Fort Severn 89 in the District of Kenora.

As was the case in our analysis of the 2001 Census data, the population figures for



SIOUX-LOOKOUT HYDRO INC.

Northern

Ontario have been adjusted to try to deal with these inconsistencies. For those communities whose populations were excluded from the 2001 Census, an estimated population figure has been calculated and added to the figure for Northern Ontario. This calculation is based on the average change in the population of all those Aboriginal communities which were included in both the 2006 Census and 2001 Census (16.5%). If a community was included in 2006 but not in 2001, a population figure for 2001 was estimated by multiplying the 2001 figure by .835. For those few communities who were included in 2001 but excluded from the 2006 Census, the 2001 population figure was multiplied by 1.165.

Section Four: Changes in the Population Since 2001

4.1 Population Changes in Canada

The growth rate of the Canadian population between 2001 and 2006 was 5.4%.¹³ This represents an increase from the previous five year period when from 1996 to 2001 the Canadian population grew by only 4%. This rate of growth was the highest of the G8 countries including the United States. Most of the population growth in Canada during this period was the result of immigration. Fully two-thirds of the population increase was due to people coming to Canada. Only one third was due to natural increase. This trend is different from that of the United States

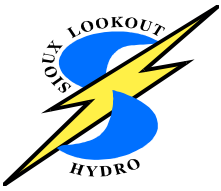
**SIOUX-LOOKOUT HYDRO INC.**

where 60% of their population growth is explained by natural increase.

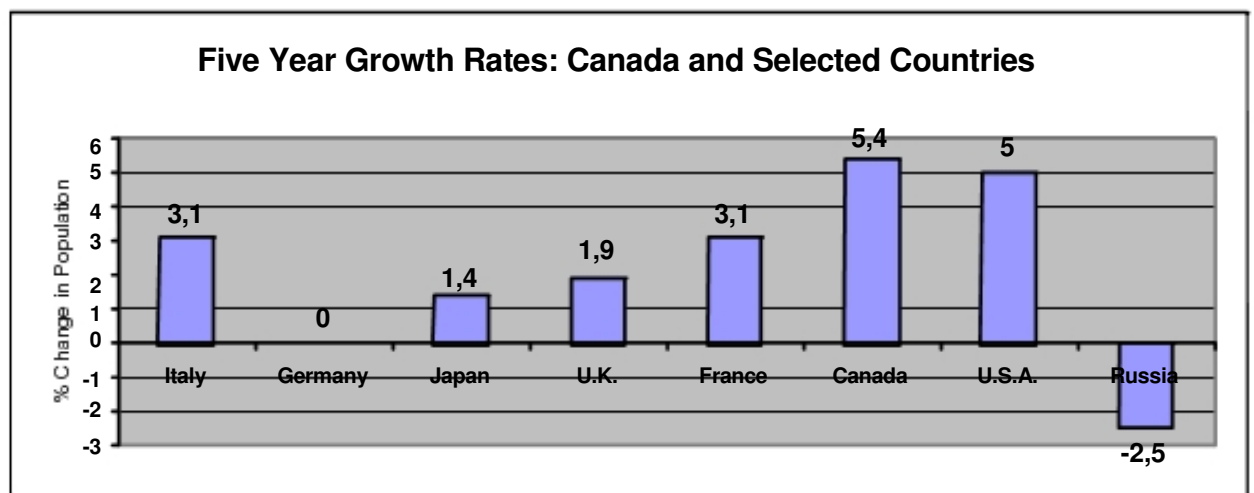

Figure 1 Source: Statistics Canada, Portrait of the Canadian Population in 2006, 2006 Census, 2006 Census Analysis Series, Catalogue no. 97-550-XIE, March, 2007.

Over two-thirds of Canada's growth in population occurred in Ontario and Alberta. Alberta was the province with the highest growth rate at 10.6% followed by Ontario with an increase of 6.6%. For Ontario, this represents an increase in the growth rate from the previous 5 year period. From 1996 to 2001 Ontario grew by 6.1%. Ontario's growth rate has been fairly steady over the past 15 years at just over 6%.

As was the case in the period from 1996 to 2001, most of the population growth occurred in the largest urban areas of Canada. The four regions with growth rates higher than the national average all are concentrated around major metropolitan centres: the southern parts of Ontario, Quebec, and British Columbia, and the Calgary-Red Deer-Edmonton corridor of Alberta. Rural areas continued to see lower than average rates of growth or population decline. According to Statistics Canada,



SIOUX-LOOKOUT HYDRO INC.

Since 2001, most rural areas grew at a slower pace than the country as a whole or, in some cases, suffered a population decline. In general, these areas are located far from the country's large urban centres. In most cases, they have natural resource-based economies, such as fishing, agriculture, forestry and mining.¹⁴

Over two-thirds of the population of Canada lived in Census Metropolitan Areas (CMAs), urban areas with a population of 100,000 or more. At the same time, not all of these urban areas experiences rapid growth. Of 33 CMAs, 15 had rates of growth higher than the national norm. Of these 15, 6 are found in the Golden Horseshoe area of southern Ontario. Almost half of Canada's population now live in the three largest urban areas: the Montreal census metropolitan area, the

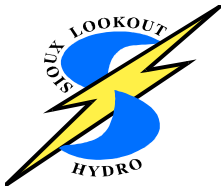

SIOUX-LOOKOUT HYDRO INC.

Vancouver census metropolitan area, and the Golden Horseshoe area. Much of the growth in these urban areas occurred in the suburban areas of these centres. The growth rates of peripheral municipalities surrounding central municipalities were twice that of the national average.

Statistics Canada lists the population figures for 111 census agglomerations (CAs), also known as mid-sized urban centres. These are centres with an urban core of at least 10,000. The average population growth for these urban communities was 4%, less than that of the nation as a whole. Most of the fastest growing CAs are located either in Alberta or within 100 kilometres of the Toronto, Montreal, or Vancouver CMAs. According to Statistics Canada, of those CAs who experienced population declines “are located in areas whose economy depends partly or completely on the exploitation of natural resources, especially forests.”¹⁵

Small town and rural areas of Canada, those with a population of less than 10,000 people, experience an overall growth rate of 1% from 2001 to 2006. Just under 20% of the Canadian population lived in these areas in 2006. Growth rates between these areas varied considerably.

Those with the highest growth rates tend to be relatively close to large urban centres. Those rural and small town communities close to large urban centres, where 30% of the labour force commutes to the urban centre, had average growth rates of 4.7%. Those rural and small town communities outside commuting distance from a large urban centre had average rate of population decline of 0.1% in 2006. Of this last group of areas, those who are in close proximity to resort locations and those that are dominated by an aboriginal population are the ones that tend to have the highest rates of growth.

Ontario’s population grew by over 750,000 people between 2001 and 2006. This represented half of all the population growth in Canada. Most of Ontario’s growth came from international immigration. Over 600,000 immigrants settled in Ontario from 2001 to 2006. Over 84% of Ontario’s growth occurred in one region: the Greater Golden Horseshoe area. The



SIoux-LOOKOUT HYDRO INC.

population of this area grew by over 630,000 people, or 8.4%.

4.2 Population Changes in Northern Ontario Compared to the Rest of Canada

As pointed out above, the population figures for the census divisions in Northern Ontario are not as reliable as the census divisions in most of Ontario. This is due to the large number of

Aboriginal communities which, for various reasons, are improperly counted. If Statistics Canada can not properly count a community, the population of that community is not included in the population totals for that census division. As a result, the population figures for almost all the census divisions in Northern Ontario are incomplete.

Taking into account these adjustments, the population of Northern Ontario in 2006 was 789,930.¹⁶ From 2001 to 2006 the population of Northern Ontario increased by 2001 people or 0.025%. Excluding the adjustments, the population of Northern Ontario is listed as 786,290 in 2006 and 786,443 in 2001, a loss of 153 people or a decline of 0.019%. This represents a distinct



SIOUX-LOOKOUT HYDRO INC.

change from the situation in 2001 when, according to adjusted figures at that time (excluding the Muskoka District Municipality) the population of the region had declined from 807,703 in 1996 to 766,073, or 5.1%¹⁷



-1,1

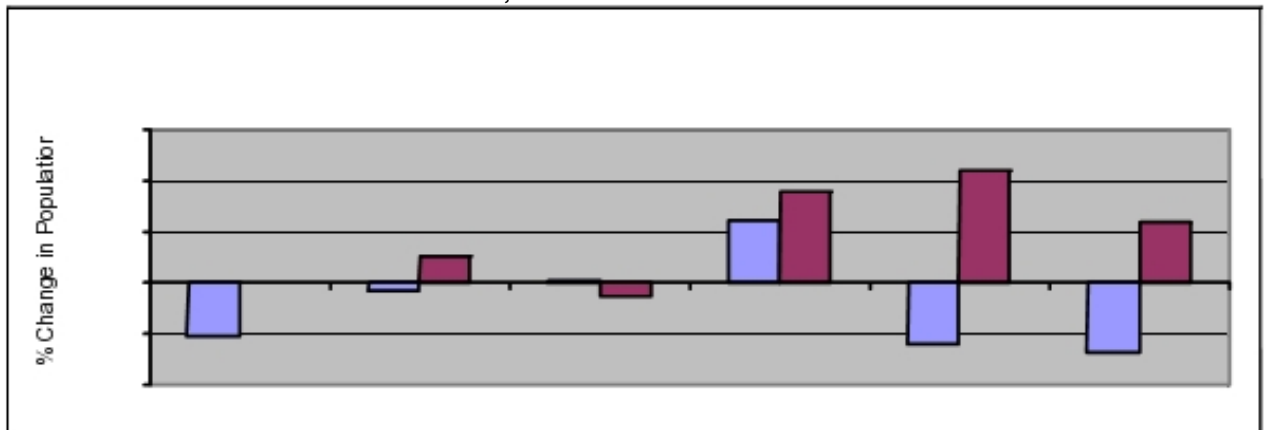



File Number: EB-2007-0785

Exhibit: 3

Tab: 2

Schedule: 2

Page: 22

SIOUX-LOOKOUT HYDRO INC.

8
6
4
2
0
-2
-4
-6



SIoux-LOOKOUT HYDRO INC.

6,1 6,6

0,025

Northern Ontario

Ontario

-5,1



File Number: EB-2007-0785

Exhibit: 3

Tab: 2

Schedule: 2

Page: 24

SIOUX-LOOKOUT HYDRO INC.

4 5,4

1996-2001
2001-2006

Canada

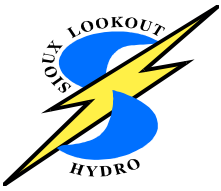

SIOUX-LOOKOUT HYDRO INC.

Figure 2 Source: Statistics Canada, Census of Canada, 1996, 2001, and 2006. Adjusted figures.

As Figure 3 indicates, there was a considerable amount of variation in growth rates for Northern resource dependent regions in Canada. Northern Ontario seemed to have the lowest rate of increase along with Northern Manitoba. Unlike the situation in 2001, the Yukon and Northwest Territories had rates of growth higher than that of Canada.¹⁸

Population Change: 1996 to 2006



SIoux-LOOKOUT HYDRO INC.

15,0		
10,0		
5,0		2,6
0,0	-5,1 0,025	-0,8
-5,0	Northern Ontario	Northern Manitoba
-10,0		



SIOUX-LOOKOUT HYDRO INC.

		11	
	8,9		5,9
6,1			
		-5,8	-6,8
0,2			
Nort hern Saskatchewan	Northern Alberta	NWTerritories	Yukon



SIOUX-LOOKOUT HYDRO INC.

Figure 1 Source: Statistics Canada, Census of Canada, 1996, 2001, and 2006.

Figure 4 shows the historical trend in the population of Northern Ontario compared to Ontario since 1951.¹⁹ Until 1961, growth rates for Northern Ontario were close to that of Ontario as a whole. In 1966 we saw for the first time an important difference in the population growth rates of Ontario and Northern Ontario. From 1966 to 1996, while the population of Ontario continued to grow, the population of Northern Ontario remained more or less stable. The previous census



SIoux-LOOKOUT HYDRO INC.

had shown the largest decrease in the population of Northern Ontario over the past 50 years. In fact, the only other time that the population of Northern Ontario decreased during this period was from 1981 to 1986 when the population decreased by 2.3%. From 2001 to 2006 the population trend returned to the general trend of stability seen from 1966 to 1996.

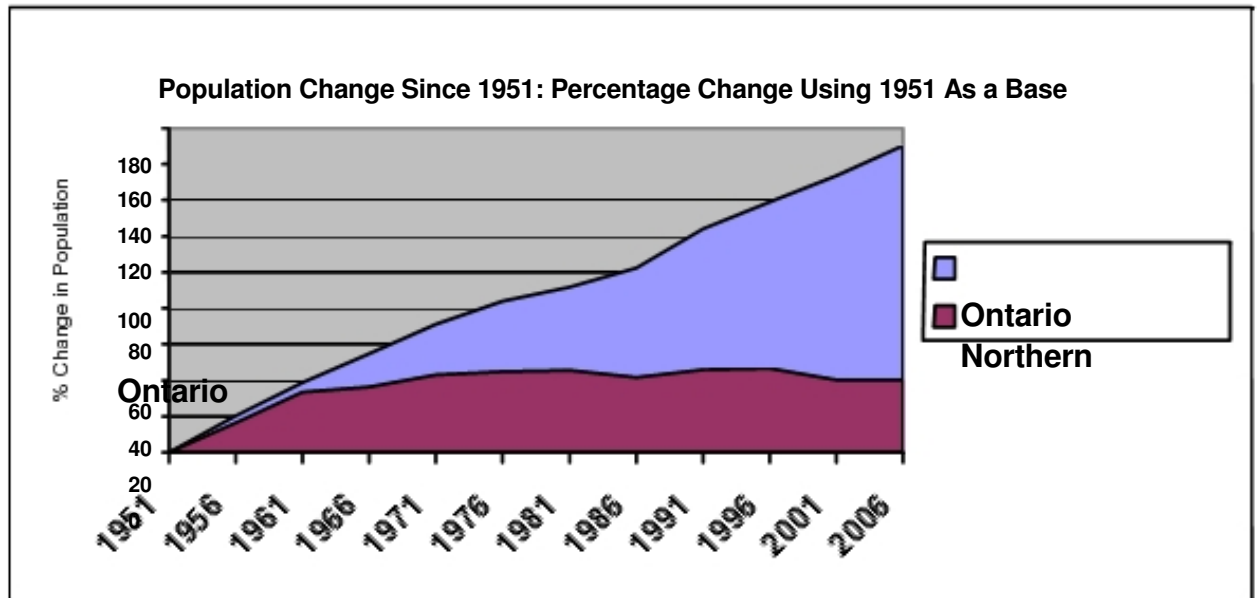

Figure 2 Source: Statistics Canada, Census of Canada, 1951 to 2006. Northern Ontario population totals for 1996-2006 are adjusted.



File Number: EB-2007-0785

Exhibit: 3

Tab: 2

Schedule: 2

Page: 30

SIOUX-LOOKOUT HYDRO INC.

1

1



SIoux-LOOKOUT HYDRO INC.

4.3 A Comparison of the Regions

Table 1: Population Change of the Regions of Northern Ontario

Region Change	2006	2001	Percentage
Northern Ontario	789930	789729	0,02
Nipissing	84688	82910	2,1
Parry Sound	40918	39665	3,2
Manitoulin	13090	12679	3,2
Sudbury	21392	22894	-6,6
Greater Sudbury / Grand Sudbury	157909	155268	1,7
Timiskaming	33283	34442	-3,4
<i>Cochrane Adjusted</i>	<i>84169</i>	<i>85247</i>	<i>-1,3</i>
<i>Algoma Adjusted</i>	<i>117461</i>	<i>119108</i>	<i>-1,4</i>
Thunder Bay	149063	<i>151148</i>	<i>-1,4</i>
Rainy River	21564	22109	-2,5
<i>Kenora Adjusted</i>	<i>66393</i>	<i>64259</i>	<i>4,2</i>

Source: Statistics Canada, Census of Canada, 2001 and 2006. Figures in italics are adjusted.

Table 1 shows the population changes in the 11 districts of Northern Ontario. From 1996 to 2001 all districts except for Manitoulin showed population declines varying from an 8.6% decline in the District of Cochrane to a 0.6% decline in the Parry Sound District. In Table 1 we can see that from 2001 to 2006 there is much more variation between the districts. The District of Kenora had the highest population growth with 4.2% followed by the Districts of Manitoulin and Parry Sound with 3.2% each. The District of Sudbury had the largest population decline at 6.6% followed by Timiskaming at 3.4%.

4.4 The Fastest Growing Communities in Northern Ontario

Looking at the census sub-divisions in Northern Ontario, of the 285 for which 2006 figures exist, the fastest growing tended to be Aboriginal communities. Of the 50 fastest



SIOUX-LOOKOUT HYDRO INC.

growing census sub-divisions, 36 were Aboriginal communities (See Appendix A). As was already mentioned, the average growth rate for Aboriginal communities in Northern Ontario was 16.5%. According to Statistics Canada, most of the growth in these Aboriginal communities was the result of a high birth rate.²⁰

Looking first at cities, the two Census Metropolitan Areas (CMAs) in Northern Ontario, Sudbury and Thunder Bay, had population increases of 1.7% and 0.8% respectively. This represented a turn around from the 1996 to 2001 when each had population declines. At the same time, the rates of growth for each CMA are well below the 6.9% average rates of growth for all CMAs in Canada.

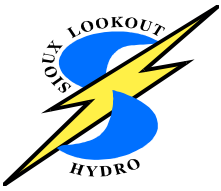

SIOUX-LOOKOUT HYDRO INC.

Table 2: Cities in Northern Ontario

Census Sub-division from 2001	Local Board	Type of Community	% Change 1996 to
North Bay	20	C	2,3
Greater Sudbury / Grand Sudbury	21	C	1,7
Temiskaming Shores	23	C	1
Sault Ste. Marie	22	C	0,5
Thunder Bay	24	C	0,1
Dryden	25	C	0
Timmins	23	C	-1,6
Elliot Lake	22	C	-3,4
Kenora	25	C	-4,2

Source: Statistics Canada, Census of Canada, 2001 and 2006.

Table 2 shows the population changes for the 9 cities of Northern Ontario. From 1996 to 2001 all cities experienced population declines. From 2001 to 2006 most cities saw some increase with the highest being 2.3% in North Bay and 1.7% in Sudbury. The cities with the largest declines were Kenora, at 3.4%, and Elliot Lake, at 1.6%.

Table 3: The Top 10 AGrowth@Towns in Northern Ontario

Census Sub-division from 2001	Local Board	Type of Community	% Change 1996 to
Latchford	23	T	21,2
Whitestone	20	MU	20,8
Magnetawan	20	MU	20
Northeastern Manitoulin and the Islands	21	T	7,1
Red Lake	25	MU	6,9
Neebing	24	MU	6,6
Killarney	21	MU	6,1



SIOUX-LOOKOUT HYDRO INC.

Temagami	20	MU	4,6
McDougall	20	MU	3,7
Kearney	20	T	3,2

Source: Statistics Canada, Census of Canada, 2001 and 2006.



SIOUX-LOOKOUT HYDRO INC.

From 1996 to 2001, only 3 towns, out of 35, showed a population increase. These were Latchford, a small town in Timiskaming, Sioux Lookout in the District of Kenora, and St.-Charles in the District of Sudbury. From 2001 to 2006, out of 40 towns and municipalities, 14 communities had increases in population. While this is an improvement on the previous census period, towns and municipalities did not do as well as most cities.

Table 3 shows that most of the top growth towns and municipalities in Northern Ontario were in the south-eastern part of the region. Of the top ten growth towns, 4 were in the District of Parry Sound, 2 were in the District of Manitoulin, and one was in the District of Nipissing.

Table 4: The Top 10 Growth Townships in Northern Ontario

Census Sub-division from	Local Board	Type of Community	% Change 1996 to 2001
Bonfield	20	TP	16.9
Carling	20	TP	11.7
Calvin	20	TP	7.3
Whitestone	20	TP	6.4
Central Manitoulin	21	TP	6.3
McMurrich/Monteith	20	TP	5.9
Tarbutt and Tarbutt Additional	22	TP	5.4
Shuniah	24	TP	5.1
Gillies	24	TP	5
Prince	22	TP	4

Source: Statistics Canada, Census of Canada, 1996 and 2001.

In 2001, of 152 townships in Northern Ontario, 31 showed a growth in population from 1996 to 2001. The fastest growing townships tended to be either in the southern areas of Northern Ontario or in close proximity to a larger urban area. In 2006, out of 94 townships and villages, 30 increased in population. Of these 30 communities, 9 were located in the District of Parry Sound and four were located in the District of Nipissing. Four were located in the



SIOUX-LOOKOUT HYDRO INC.

District of
Algoma. All four of these townships are in relative proximity to Sault Ste. Marie
and have
substantial lakeshore areas. Likewise, the two townships with growth located in
the District of Thunder Bay are close to the City of Thunder Bay.



File Number: EB-2007-0785

Exhibit: 3

Tab: 2

Schedule: 2

Page: 38

SIOUX-LOOKOUT HYDRO INC.

5
0
-5
-10



File Number: EB-2007-0785

Exhibit: 3

Tab: 2

Schedule: 2

Page: 39

SIOUX-LOOKOUT HYDRO INC.

4.3

0.3

LAB#20



SIoux-LOOKOUT HYDRO INC.

1.1

-1.2

-2.1

-5.5

-6.8

-8.5

LAB#21

LAB#22

LAB #23



SIOUX-LOOKOUT HYDRO INC.

	1.7	0.025	
-1.4			1996-2001
-4.4	-3		2001-2006
		-4.5	
LAB #24	LAB #25	Northern Ont.	



SIOUX-LOOKOUT HYDRO INC.

Figure 3 Source: Statistics Canada, Census of Canada, 1996, 2001, and 2006.

4.5.1 The Muskoka, Nipissing, Parry Sound Local Training and Adjustment Board (Board #20)

As is shown in Figure 5, population trends changed substantially from 2001 to 2006 for all northern boards. From 1996 to 2001 only one of the 6 Local Area Training Boards in Northern Ontario, Local Board #20, increased its population from 1996 to 2001. Local Board #23, also known as the Far Northeast Training Board saw its population decline by 8.5%. From 2001 to 2006, three of the Boards saw population increases: Local Boards #20, 21, and 25. The other boards saw their population declines significantly reduced. Board #23 saw its decline reduced from 8.5% to 2.1%.

Table 5: Communities in LB #20

Community Change in	Type of Community	2006	2001	Change in Population	%
LTAB# 20		183169	175681	7488	4,3
Bracebridge	T 13,8	15652	13751	1901	
Georgian Bay	TP 17,5	2340	1991	349	
Gravenhurst	T	11046	10899	147	1,3
Huntsville	T	18280	17338	942	5,4
Lake of Bays	TP 23,1	3570	2900	670	
Moose Point 79	IRI 12,4	208	185	23	
Muskoka Lakes	TP	6467	6042	425	7
Wahta Mohawk Territory	IRI	inc	inc		
Bear Island 1	IRI	inc	inc		
Bonfield	TP 2,7	2009	2064	-55	-
Calvin	TP	608	603	5	0,8



File Number: EB-2007-0785

Exhibit: 3

Tab: 2

Schedule: 2

Page: 43

SIOUX-LOOKOUT HYDRO INC.



SIOUX-LOOKOUT HYDRO INC.

Chisholm	TP	1318	1230	88	7,2
East Ferris	TP	4200	4291	-91	-
2,1					
Mattawa	T	2003	2270	-267	-
11,8					
Mattawan	TP	147	114	33	
	28,9				
Nipissing 10	IRI	1413	1378	35	2,5
Nipissing, Unorganized, North	NO	1798	1856	-58	-
3,1					
Part					
Nipissing, Unorganized, South	NO	571	51	520	
	1019,6				
Part					
North Bay	CY	53966	52771	1195	2,3
Papineau-Cameron	TP	1058	997	61	6,1
South Algonquin	TP	1253	1278	-25	-2
Temagami	MU	934	893	41	4,6
West Nipissing / Nipissing Ouest	M	13410	13114	296	2,3
Armour	TP	1249	1326	-77	-
5,8					
Burk's Falls	VL	893	940	-47	-5
Callander	MU	3249	3177	72	2,3
Carling	TP	1123	1063	60	5,6
Dokis 9	IRI	195	196	-1	-
0,5					
French River 13	IRI	99	121	-22	-
18,2					
Henvey Inlet 2	IRI	15	15	0	0
Joly	TP	280	290	-10	-
3,4					
Kearney	T	798	773	25	3,2
Machar	TP	866	849	17	2
Magnetawan	MU	1610	1342	268	20
Magnetawan 1	IRI	78	73	5	6,8
McDougall	MU	2704	2608	96	3,7
McKellar	TP	1080	933	147	
	15,8				
McMurrich/Monteith	TP	791	766	25	3,3
Naiscoutaing 17A	IRI	0	0	0	



SIOUX-LOOKOUT HYDRO INC.

Nipissing	TP	1642	1553	89	5,7
Parry Island First Nation 6,7	IRI	350	375	-25	-
Parry Sound	T	5818	6124	-306	-5
Parry Sound, Unorganized,	NO	2424	2198	226	
	10,3				
Centre Part					
Parry Sound, Unorganized, North	NO	236	185	51	
	27,6				
East Part					
Perry 10,7	TP	2010	2252	-242	-
Powassan	MU	3309	3252	57	1,8
Ryerson	TP	686	632	54	8,5
Seguin	TP	4276	3698	578	
	15,6				
Shawanaga 17	IRI	193	174	19	
	10,9				
South River	VL	1069	1040	29	2,8
Strong 3,1	TP	1327	1369	-42	-



SIOUX-LOOKOUT HYDRO INC.

Sundridge	VL	942	983	-41	-
4,2					
The Archipelago	TP	576	505	71	
	14,1				
Whitestone	MU	1030	853	177	
	20,8				

(1) Adjusted population Source: Statistics Canada, Census of Canada, 2001 and 2006.

Table 5 shows that for Local Board #20, growth came from communities in the Muskoka District Municipality. The population in this particular census division grew by 8.4%, a rate higher than that of Canada and Ontario. The population of the District of Parry Sound increased by 3.2% while that of the Nipissing District increased by 2.1%. Just as the was the case in 2001, it is clear that communities in the Board #20 area are benefiting from their relative proximity to the urban centres of Southern Ontario.

4.5.2 Sudbury and Manitoulin Training and Adjustment Board (Board #21)

Local Board #21, also known as the Sudbury and Manitoulin Training and Adjustment Board, includes the District of Manitoulin, the Greater Sudbury Area, and most of the District of Sudbury. From 1996 to 2001, the area experienced a population decline of 5.5%. Most of this decline came from the Sudbury urban area which declined by 6.1%. The overall population of Manitoulin Island remained virtually unchanged from 1996 to 2001 due to growth in the Aboriginal communities. Overall the District of Sudbury had a population decline of just over 4%. Despite this, the process of Asuburbanization@ had meant some growth in communities surrounding the city of Sudbury.

From 2001 to 2006, the Local Board #21 had the biggest turnaround in population change. The area grew by 1.1%. Most of this growth was the result of increases in the Census Metropolitan Area of Great Sudbury which grew by 1.7%. Communities in the District of Manitoulin grew by an average of 3.2%, most of the growth coming from the districts Aboriginal communities. The District of Sudbury was that region of Northern Ontario that had the largest



SIOUX-LOOKOUT HYDRO INC.

decline in population, at 6.6%.

Table 6: Communities in LB #21

Change Community	Type of Community in	2006	2001	Change in Population	% Popul
ation					
Board 21		189736	187717	2019	1.1
Assiginack	TP	914	931	-17	-1.8
Barrie Island	TP	47	50	-3	-6
Billings	TP	539	551	-12	-2.2
Burpee and Mills	TP	329	362	-33	-9.1
Central Manitoulin	TP	1944	1907	37	1.9
Cockburn Island	TP	10	0	10	
Gordon	TP	412	473	-61	-12.9
Gore Bay	T	924	898	26	2.9
					1
					7



SIOUX-LOOKOUT HYDRO INC.

Killarney	MU	454	428	26	6.1
M'Chigeeng 22 (West Bay 22)	IRI	766	729	37	5.1
Manitoulin, Unorganized, Mainland	NO	5	0	5	
Manitoulin, Unorganized, West Part	NO	222	204	18	8.8
Northeastern Manitoulin and the Islands	T	2711	2531	180	7.1
Sheguiandah 24	IRI	160	121	39	32.2
Sheshegwaning 20	IRI	107	88	19	21.6
Sucker Creek 23	IRI	346	310	36	11.6
Tehkummah	TP	382	367	15	4.1
Whitefish River (Part) 4	IRI	379	268	111	41.4
Wikwemikong Unceded	IRI	2387	2427	-40	-1.6
Zhiibaahaasing 19 (Cockburn Island 19)	IRI	0	0	0	
Zhiibaahaasing 19A (Cockburn Island 19A)	IRI	52	34	18	52.9
Baldwin	TP	554	624	-70	-11.2
Duck Lake 76B	IRI	82	107	-25	-23.4
Espanola	T	5314	5449	-135	-2.5
French River / Rivière des Français	M	2659	2810	-151	-5.4
Markstay-Warren	MU	2475	2627	-152	-5.8
Nairn and Hyman	TP	493	420	73	17.4
Sables-Spanish Rivers	TP	3237	3245	-8	-0.2
St.-Charles	MU	1159	1245	-86	-6.9
Sudbury, Unorganized, North Part	NO	2415	2910	-495	-17
Whitefish Lake 6	IRI	349	333	16	4.8
Whitefish River (Part) 4	IRI	0	0	0	
Greater Sudbury / Grand Sudbury	C	157857	155219	2638	1.7
Wahnapitei 11	IRI	52	49	3	6.1

(1) Adjusted population Source: Statistics Canada, Census of Canada, 2001 and 2006.



File Number: EB-2007-0785

Exhibit: 3

Tab: 2

Schedule: 2

Page: 49

SIOUX-LOOKOUT HYDRO INC.



SIOUX-LOOKOUT HYDRO INC.

4.5.3 Local Board #22:²¹

Local Board #22, whose area comprises most of the District of Algoma, lost 8,575 people between 1996 and 2001, or 6.8% of its population. Most of the loss occurred in the city of Sault Ste. Marie which declined by 6.9%. Other notable losses were in Elliot Lake, which lost 12% of its population, and Michipicoten, which, due to the closure of the Algoma mining operations, lost 11.5% of its population. In 2001 the six fastest growing census sub-divisions were all Aboriginal communities. Besides these six communities, the only other census sub-divisions in the Board 20 area that had an increase in population were four townships relatively close to Sault Ste. Marie which all had a high percentage of lakefront property.

From 2100 to 2006 the population of Local Board #22 decreased by the relatively small percentage of 1.2%. Unlike the situation in 2001, the City of Sault Ste. Marie actually grew by 0.5%. Growth was once again centred in Aboriginal communities and townships with substantial lakefront areas. The largest declines occurred in Elliot Lake and the northern communities of Algoma such as Michipicoten, Dubreuilville, and White River.

Table 7: Communities in LB #22

Community Change	Type of Community	2006	2001	Change in Population	% in Popul
LB#22 (1)		116252	117746	-1494	-1.2
Algoma, Unorganized, North Part	NO	5717	6114	-397	-6.5
Algoma, Unorganized, South East Part	NO	0	0	0	
Blind River	T	3780	3969	-189	-4.8
Bruce Mines	T	584	627	-43	-6.9
Dubreuilville	TP	773	967	-194	-20.1
Elliot Lake	CY	11549	11956	-407	-3.4
Garden River 14	IRI	985	859	126	14.7



SIOUX-LOOKOUT HYDRO INC.

Goulais Bay 15A (1)	IRI	82	68	14	
Gros Cap 49	IRI	54	61	-7	-11.5
Hilton	TP	243	258	-15	-5.8
Hilton Beach	VL	172	174	-2	-1.1
Huron Shores	MU	1696	1794	-98	-5.5
Jocelyn	TP	277	298	-21	-7
Johnson	TP	701	658	43	6.5
Laird	TP	1078	1021	57	5.6
Macdonald, Meredith and Aberdeen Additional	TP	1550	1452	98	6.7
Michipicoten	TP	3204	3668	-464	-12.6



SIOUX-LOOKOUT HYDRO INC.

Missanabie 62	IRI	0	0	0	
Mississagi River 8	IRI	414	360	54	15
North Shore	TP	549	544	5	0.9
Plummer Additional	TP	625	671	-46	-6.9
Prince	TP	971	1010	-39	-3.9
Rankin Location 15D (1)	IRI	566	473	93	
Sagamok	IRI	884	870	14	1.6
Sault Ste. Marie	CY	74948	74566	382	0.5
Serpent River 7	IRI	340	323	17	5.3
Spanish	T	728	816	-88	-10.8
St. Joseph	TP	1129	1201	-72	-6
Tarbutt and Tarbutt Additional	TP	388	466	-78	-16.7
Thessalon	T	1312	1386	-74	-5.3
Thessalon 12	IRI	112	123	-11	-8.9
White River	TP	841	993	-152	-15.3

(1) Adjusted population Source: Statistics Canada, Census of Canada, 2001 and 2006.

4.5.4 The Far Northeast Training and Adjustment Board (Board #23)

Local Board #23, also known as the Far Northeast Training and Adjustment Board, comprises the Districts of Cochrane and Timiskaming and small parts of the Districts of Kenora, Algoma, and Sudbury. From 1996 to 2001 the area declined by 11,863, or 8.5%. The census sub-division which showed the largest decline in absolute numbers was the city of Timmins, which declined by 3,813 people or 8%. Next came Kirkland Lake which had a decline of 1,289 people or 13% of its population. There were 13 census sub-divisions which showed a growth in population from 1996 to 2001. Of these, 9 were Aboriginal communities.

From 2001 to 2006 the population decline of communities in the Board 23 area slowed considerably to an average of 2.1%. Growth occurred in 3 Aboriginal communities, the newly created city of Temiskaming Shores, and the town of Moonbeam. Declines occurred in many of the forestry dependent communities of the regions such as Kapuskasing, Chapleau, Smooth Rock Falls, and Iroquois Falls. The city of Timmins also saw a decline of 1.6%.

Table 8: Communities in LB #23



SIOUX-LOOKOUT HYDRO INC.

Community Change	Type of Community	2006	2001	Change in Population	% in Populat
ion					
LB#23 (1)		<i>123043</i>	125661	-2618	-2.1
Armstrong	TP	1155	1223	-68	-5.6
Brethour 25.5	TP	117	157	-40	-
Casey	TP	385	421	-36	-8.6
Chamberlain	TP	322	348	-26	-7.5
Charlton and Dack 12.7	MU	613	702	-89	-
					2
					0



SIOUX-LOOKOUT HYDRO INC.

Cobalt	T	1229	1229	0	0
Coleman	TP	431	550	-119	-
21.6					
Englehart	T	1494	1595	-101	-6.3
Evanturel	TP	473	506	-33	-6.5
Gauthier	TP	133	128	5	3.9
Harley	TP	551	557	-6	-1.1
Harris	TP	512	518	-6	-1.2
Hilliard	TP	222	241	-19	-7.9
Hudson	TP	305	490	-185	-
37.8					
James	TP	414	467	-53	-
11.3					
Kerns	TP	325	360	-35	-9.7
Kirkland Lake	T	8248	8616	-368	-4.3
Larder Lake	TP	735	790	-55	-7
Latchford	T	446	368	78	
21.2					
Matachewan	TP	375	308	67	
21.8					
Matachewan 72	IRI	72	61	11	18
McGarry	TP	674	787	-113	-
14.4					
Temiskaming Shores	CY	10732	10630	102	1
Thornloe	VL	105	120	-15	-
12.5					
Timiskaming, Unorganized, East Part	NO	10	0	10	
Timiskaming, Unorganized, West Part	NO	3205	3270	-65	-2
Abitibi 70	IRI	114	127	-13	-
10.2					
Black River-Matheson	TP	2619	2886	-267	-9.3
Cochrane	T	5487	5690	-203	-3.6
Cochrane, Unorganized, North Part (2)	NO	2447	2975	-528	
Cochrane, Unorganized, South East Part	NO	25	21	4	19
Cochrane, Unorganized, South West Part	NO	0	0	0	



SIOUX-LOOKOUT HYDRO INC.

Constance Lake 92	IRI	702	723	-21	-2.9
Factory Island 1 (1)	IRI	1666	1430	236	
Fauquier-Strickland 16.2	TP	568	678	-110	-
Flying Post 73	IRI	40	0	40	
Fort Albany (Part) 67	IRI	1805	441	1364	
		309.3			
Hearst	T	5620	5825	-205	-3.5
Iroquois Falls	T	4729	5217	-488	-9.4
Kapuskasing	T	8509	9238	-729	-7.9
Mattice-Val Côté 13.4	TP	772	891	-119	-
Moonbeam	TP	1298	1201	97	8.1
Moose Factory 68	IRI	0	0	0	
Moosonee (2)	TV	2006	936	1070	

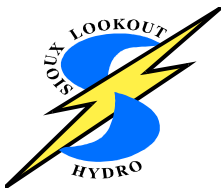

SIOUX-LOOKOUT HYDRO INC.

New Post 69	IRI	0	0	0	
New Post 69A	IRI	73	105	-32	-
30.5					
Opasatika	TP	280	325	-45	-
13.8					
Smooth Rock Falls	T	1473	1830	-357	-
19.5					
Timmins	CY	42997	43686	-689	-1.6
Val Rita-Harty	TP	939	1022	-83	-8.1
Chapleau	TP	2354	2832	-478	-
16.9					
Chapleau 74A	IRI	20	33	-13	-
39.4					
Chapleau 75	IRI	92	93	-1	-1.1
Mattagami 71	IRI	189	166	23	
13.9					
Mountbatten 76A	IRI	0	0	0	
Hornepayne	TP	1209	1362	-153	-
11.2					
Attawapiskat 91A (1)	IRI	1506	1293	213	
Peawanuck	S-É	221	193	28	
14.5					

(1) Adjusted population, (2) Uncertain count in 2001. Source: Statistics Canada, Census of Canada, 2001 and 2006.

4.5.5 North Superior Training Board (Board #24)

Local Board #24 is also known as the North Superior Training Board. It comprises the District of Thunder Bay and several Aboriginal communities just north of the boundaries of the District of Thunder Bay. From 1996 to 2001 this area showed a decline in population of 6,973 people, or 4.4%. Most of the decline came in the city of Thunder Bay which declined by 4,646 people or 4.1%. Other communities with notable declines were Schreiber, which declined by 19% as a result of a mine closure, and Terrace Bay, which declined by 16.1%. Statistics Canada had listed the newly formed community of Greenstone as being the community with a population over

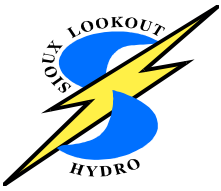

SIOUX-LOOKOUT HYDRO INC.

5,000 which had the largest decline in Canada from 1996 to 2001. Statistics Canada now indicates that its initial population count was wrong and the population decline of Greenstone was not that severe. Of the 36 census sub-divisions in the LB #24 area, 17 increased in population from 1996 to 2001. Among these 17 census sub-divisions, 14 were Aboriginal communities. The other 3 were suburb communities of the city of Thunder Bay.

From 2001 to 2006 the rate of population decline in this region slowed considerably, to 1.4%. The main explanation for this change is that the City of Thunder Bay which went from a decline of 4.1% in 2001 to a slight growth of 0.1% in 2006. Other than the City of Thunder Bay, of the 12 communities the increased in population, 8 were Aboriginal communities and 3 were suburb communities of Thunder Bay.



SIOUX-LOOKOUT HYDRO INC.

Table 9: Communities in LB #24

Community Change	Type of Community	2006	2001	Change in Population in	% Popul
ation					
LB#24 (1)		151183	153295	-2112	-1.4
Aroland 83	IRI	325	346	-21	-6.1
Conmee	TP	740	748	-8	-1.1
Dorion	TP	379	442	-63	-14.3
Fort William 52	IRI	909	599	310	51.8
Gillies	TP	544	522	22	4.2
Ginoogaming First Nation	IRI	175	231	-56	-24.2
Greenstone (2)	MU	4906	5662	-756	-13.3
Gull River 55	IRI	206	252	-46	-18.3
Lac des Mille Lacs 22A1	IRI	21	0	21	
Lake Helen 53A	IRI	283	274	9	3.3
Long Lake 58	IRI	417	382	35	9.2
Manitouwadge	TP	2300	2949	-649	-22
Marathon	T	3863	4416	-553	-12.5
Neebing	MU	2184	2049	135	6.6
Nipigon	TP	1752	1964	-212	-10.8
O'Connor	TP	720	724	-4	-0.6
Ojibway Nation of Saugeen (Savant Lake) (1)	IRI	98	82	16	
Oliver Paipoonge	MU	5757	5862	-105	-1.8
Osnaburgh 63A	IRI	153	187	-34	-18.2
Pays Plat 51	IRI	79	65	14	21.5
Pic Moberth North	IRI	137	167	-30	-18
Pic Moberth South	IRI	104	140	-36	-25.7
Pic River 50	IRI	383	346	37	10.7
Red Rock	TP	1063	1233	-170	-13.8
Rocky Bay 1	IRI	154	197	-43	-21.8
Schreiber	TP	901	1448	-547	-37.8
Seine River 22A2	IRI	0	0	0	



SIOUX-LOOKOUT HYDRO INC.

Shuniah	TP	2913	2466	447	18.1
Terrace Bay	TP	1625	1950	-325	-16.7
Thunder Bay	CY	109140	109016	124	0.1
Thunder Bay, Unorganized	NO	6585	6223	362	5.8
Whitesand (1)	IRI	247	206	41	
Fort Hope 64	IRI	1144	1001	143	14.3
Summer Beaver	S-É	362	276	86	31.2

2
3



SIOUX-LOOKOUT HYDRO INC.

Webequie	IRI	614	600	14	2.3
Lansdowne House	S-É	0	270	-270	-100

(1) Adjusted population, (2) Uncertain count in 2001. Source: Statistics Canada, Census of Canada, 2001 and 2006.

4.5.6 The Northwest Training and Adjustment Board (Board #25)

Local Board #25 is also known as the Northwest Training and Adjustment Board. It is comprised of the District of Rainy River and most of the District of Kenora. From 1996 to 2001 its population declined by 2,563 people, or 3%. Most of this loss occurred in the Aboriginal community of Fort Albany (Part) 67 which is listed as having lost its entire population of 1,004 people from 1996 to 2001. Important losses also occurred in Red Lake, which lost 11.4% of its population, and the city of Kenora, which lost 527 people, or 3.2% of its population. Of 82 census sub-divisions in this area, 40 increased in population from 1996 to 2001. Of these 40, 37 were Aboriginal communities. Sioux Lookout, the only town in Northwestern Ontario to increase in population from 1996 to 2001, owed its increase to its importance as a service centre for surrounding Aboriginal communities.

From 2001 to 2006 the Local Board 25 area increased its population by 1.7%. Of the 41 communities that saw their population increase during this period, 35 were Aboriginal communities. The mining communities of Pickle Lake and Red Lake were among the 6 remaining growth communities as was the community of Sioux Narrows-Nestor Falls. Communities with the largest decline in populations tended to be forest industry dependent communities such as Kenora, Atikokan, Ignace, Machin, and Fort Frances.

Table 10: Communities in LB#25

Community	Type of	2006	2001	Change in



SIOUX-LOOKOUT HYDRO INC.

ation	% Change Community			Population	in Popul
LB#25 (1)		84109	82734	1375	1.7
Agency 1	IRI	0	0	0	
Alberton	TP	958	956	2	0.2
Atikokan	TP	3293	3632	-339	-9.3
Big Grassy River 35G	IRI	204	176	28	15.9
Big Island Mainland 93	IRI	10	85	-75	-88.2
Chapple	TP	856	910	-54	-5.9
Couchiching 16A	IRI	691	595	96	16.1
Dawson	TP	620	613	7	1.1
Emo	TP	1305	1331	-26	-2
Fort Frances	T	8103	8315	-212	-2.5
La Vallee	TP	1067	1073	-6	-0.6
					2
					4



SIOUX-LOOKOUT HYDRO INC.

Lake of the Woods	TP	323	330	-7	-2.1
Long Sault 12	IRI	33	48	-15	-31.3
Manitou Rapids 11	IRI	228	191	37	19.4
Morley	TP	492	526	-34	-6.5
Neguaguon Lake 25D	IRI	257	207	50	24.2
Rainy Lake 17A	IRI	183	200	-17	-8.5
Rainy Lake 17B	IRI	5	0	5	
Rainy Lake 18C	IRI	95	81	14	17.3
Rainy Lake 26A	IRI	128	93	35	37.6
Rainy River	T	909	981	-72	-7.3
Rainy River, Unorganized	NO	1431	1526	-95	-6.2
Sabaskong Bay (Part) 35C	IRI	0	0	0	
Saug-a-Gaw-Sing 1	IRI	101	10	91	910
Seine River 23A	IRI	272	230	42	18.3
Seine River 23B	IRI	0	0	0	
Bearskin Lake	IRI	459	363	96	26.4
Cat Lake 63C	IRI	492	428	64	15
Deer Lake	IRI	681	756	-75	-9.9
Dryden	CY	8195	8198	-3	0
Eagle Lake 27	IRI	232	211	21	10
Ear Falls	TP	1153	1150	3	0.3
English River 21	IRI	633	454	179	39.4
Fort Albany (Part) 67	IRI	5	0	5	
Fort Severn 89 (1)	IRI	467	401	66	
Ignace	TP	1431	1709	-278	-16.3
Kasabonika Lake	IRI	681	740	-59	-8
Kee-Way-Win	IRI	318	265	53	20
Kenora	CY	15177	15838	-661	-4.2
Kenora 38B	IRI	350	119	231	
		194.1			
Kenora, Unorganized	NO	7041	7631	-590	-7.7
Kingfisher Lake 1	IRI	415	368	47	12.8
Kitchenuhmaykoosib Aaki 84 (Big	IRI	916	435	481	
		110.6			
Trout Lake)					
Lac Seul 28	IRI	821	702	119	17
Lake Of The Woods 31G	IRI	0	0	0	
Lake Of The Woods 37	IRI	58	99	-41	-41.4



SIOUX-LOOKOUT HYDRO INC.

MacDowell Lake	S-É	0	0	0	
Machin	TP	978	1143	-165	-14.4
Marten Falls 65 (1)	IRI	221	184	37	
Muskrat Dam Lake	IRI	252	61	191	
		313.1			
Neskantaga	IRI	265	0	265	
North Spirit Lake	IRI	259	231	28	12.1
Northwest Angle 33B	IRI	40	97	-57	-58.8
Osnaburgh 63B	IRI	347	283	64	22.6

2
5

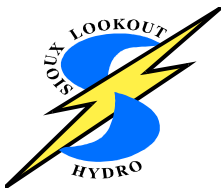

SIOUX-LOOKOUT HYDRO INC.

Pickle Lake	TP	479	399	80	20.1
Pikangikum 14 (1)	IRI	2100	1753	347	
Poplar Hill	IRI	457	373	84	22.5
Rat Portage 38A	IRI	316	182	134	73.6
Red Lake	MU	4526	4233	293	6.9
Sabaskong Bay (Part) 35C	IRI	0	0	0	
Sabaskong Bay 35D	IRI	390	346	44	12.7
Sachigo Lake 1	IRI	450	443	7	1.6
Sachigo Lake 2	IRI	0	0	0	
Sandy Lake 88	IRI	1843	1704	139	8.2
Shoal Lake (Part) 39A	IRI	346	330	16	4.8
Shoal Lake (Part) 40	IRI	105	0	105	
Shoal Lake 34B2	IRI	126	140	-14	-10
Sioux Lookout	MU	5183	5336	-153	-2.9
Sioux Narrows - Nestor Falls	TP	672	577	95	16.5
Slate Falls	S-É	164	156	8	5.1
The Dalles 38C	IRI	156	118	38	32.2
Wabaseemoong	IRI	786	388	398	
		102.6			
Wabauskang 21	IRI	85	51	34	66.7
Wabigoon Lake 27	IRI	147	153	-6	-3.9
Wapekeka 1	IRI	0	0	0	
Wapekeka 2	IRI	350	329	21	6.4
Wawakapewin (Long Dog Lake)	IRI	21	31	-10	-32.3
Weagamow Lake 87	IRI	700	697	3	0.4
Whitefish Bay 32A (1)	IRI	622	519	103	
Whitefish Bay 33A	IRI	53	48	5	10.4
Whitefish Bay 34A	IRI	94	46	48	
		104.3			
Wunnumin 1	IRI	487	407	80	19.7
Wunnumin 2	IRI	0	0	0	

(1) Adjusted population Source: Statistics Canada, Census of Canada, 2001 and 2006.



File Number: EB-2007-0785

Exhibit: 3

Tab: 2

Schedule: 2

Page: 65

SIOUX-LOOKOUT HYDRO INC.



SIOUX-LOOKOUT HYDRO INC.

Section Five: Observations

Following the 2001 Census we identified four main population trends occurring in Northern Ontario. The most important was a general decline in population. This decline occurred in the major urban areas of the region as well as the non-Aboriginal resource dependent communities of the region. At the time there did not appear to be much of an overall difference in rates of decline based on the main economic activity of the region. Pulp and paper towns, sawmill towns, and mining towns all decreased in size although the extent of the decrease varied from community to community.

The next trend identifies was the relatively high rates of growth due to natural increase in the Aboriginal communities of the region. Overall, in 2001, the average rate of growth for these communities was 5.9% in Northern Ontario. While this growth rate was slightly less than the 6.1% growth rate for Ontario, it was substantially higher than the 4% growth rate for Canada. Another trend was a slow increase in the Acottage country@ communities closest to the major urban areas of Southern Ontario. This was clearly seen in the Muskoka District Municipality but also in some communities in the District of Parry Sound. Finally, some growth was seen in the suburban areas surrounding the largest urban centres of Northern Ontario. Those townships with lakefront seemed to have the most growth.

Some of these trends have reappeared following the 2006 Census but there are important differences. The first is that the population has stabilized. Statistically speaking the population of Northern Ontario was virtually the same in 2006 as it was in 2001. While this indicates that the socio-economic situation in most Northern Ontario communities is better than that found from 1996 to 2001, it still needs to be pointed out that Northern Ontario is still shrinking as a



SIOUX-LOOKOUT HYDRO INC.

percentage of the population of Ontario. In 2001 Northern Ontario represented 6.9% of the total population of Ontario. By 2006 this percentage was down to under 6.5%. While the population of Northern Ontario has stabilized, the southern urban area of the province continues to experience rapid growth.

High growth rates in most Aboriginal communities in Northern Ontario were also seen in the years from 2001 to 2006. Average growth rates for these communities increased to 16.5%. These communities continue to be the most dynamic in the region.

Another noticeable trend is a return of growth to the largest urban centres. The urban areas of North Bay, Sudbury, Sault Ste. Marie, and Thunder Bay all saw their population grow during this period. Indeed much of the growth of the non-aboriginal population occurred in these cities. This may support the belief outlined in several TOPS reports that the largest urban centres are best placed to adapt themselves away from the traditional resource industry economy and towards the knowledge-based economy.

One trend that is indicated in the population figures but which needs to be examined when



SIoux-LOOKOUT HYDRO INC.

industry data is released is that mining dependent communities were better off than forest dependent communities. While there were exceptions, several mining communities across the region such as Sudbury, Pickle Lake, and Red Lake all saw growth from 2001 to 2006. Many forest dependent communities continued to experience similar declines to those they had experienced from 1996 to 2001.

Finally, as was the case in the previous census period, those communities that are closest to the urban centres of Southern Ontario tended to have growth as opposed to decline. We see growth increasing in the traditional cottage country areas of Muskoka and Parry Sound but we are seeing these trends creeping into more northern areas of the District of Parry Sound and into certain areas of the Nipissing District.

Notes _____

1. As this report is being written, Board #22, covering most of the Algoma District, has only recently been reestablished as a formal training board after having been dissolved in 2001. Despite this, the report includes data for this Board area.

² Southcott, Chris. Population Change in Northern Ontario: 1996 to 2001 2001 Census Research Paper Series: Report #1, North Bay: Northern Ontario Training Boards, _____
2002.

3. This has been pointed out by several government studies undertaken over the past 30 years including the Royal Commission on the Northern Environment (Fahlgren Commission). Final Report, Toronto, 1985 and the _____
Task Force on Resource Dependent Communities in Northern Ontario, (the Rosehart Report) Final Report., 1986.



SIOUX-LOOKOUT HYDRO INC.

4. For an elaboration on these points see Dadgostar, B., Jankowski, W.B., and Moazzami, B. *The Economy of Northwestern Ontario: Structure, Performance and Future Challenges*, Thunder Bay: Centre for Northern Studies, Lakehead University, 1992.

5. For a detailed discussion of this aspect of Northern Ontario see McBride, Stephen, McKay, Sharon, and Hill, Mary Ellen. "Unemployment in a Northern Hinterland: The Social Impact of Political Neglect" in Chris Southcott (ed.) *A Provincial Hinterland: Social Inequality in Northwestern Ontario*, Halifax: Fernwood, 1993.

6. Canada, 2006 Census.



SIOUX-LOOKOUT HYDRO INC.

7. An elaboration on these unique characteristics can be found in Randall, James and R. G. Ironside “Communities on the Edge: An Economic Geography of Resource-Dependent Communities in Canada” The Canadian Geographer 40(10):17-35, 1996.

8. Census population statistics for First Nations communities tend to be less reliable than those for non-Native communities. These statistics are based on 2001 Census data as 2006 data was not available at the time this report was prepared.

⁹ The following reports were reviewed:

The Muskoka, Nipissing, Parry Sound Local Training and Adjustment Board, Trends, Opportunities, and Priorities Report 2004, North Bay, 2004.

The Muskoka, Nipissing, Parry Sound Local Training and Adjustment Board, Trends, Opportunities, and Priorities Report 2006-2007, North Bay, 2007.

The Sudbury and Manitoulin Training and Adjustment Board, Trends, Opportunities, and Priorities Report 2004, Sudbury, 2004.

The Sudbury and Manitoulin Workforce Partnership Board, Trends, Opportunities, and Priorities Report 2006, Sudbury, 2006.

The Far Northeast Training Board, Trends, Opportunities, and Priorities Report 2004, Hearst, 2004.

The Far Northeast Training Board, Trends, Opportunities, and Priorities Report Update 2005, Hearst, 2005.

The Far Northeast Training Board, Trends, Opportunities, and Priorities Report 2007, Hearst, 2007.

The North Superior Training Board, Trends, Opportunities, and Priorities Labour Market Report 2004, Thunder Bay, 2004.

The North Superior Training Board, Trends, Opportunities, and Priorities Report 2006, Thunder Bay, 2006.

The North Superior Training Board, Trends, Opportunities, and Priorities Report 2007, Thunder Bay, 2007.

The Northwest Training and Adjustment Board, Trends, Opportunities, and Priorities Report 2006, Dryden, 2006



SIoux-LOOKOUT HYDRO INC.

10. See Southcott, Chris. Youth Out-migration in Northern Ontario, 2001, Census Research Paper Series: Report #2, North Bay: Training Boards of Northern Ontario, 2002, p.7. There is also the problem of “missed” individuals. See Statistics Canada. Profile of the Canadian population by age and sex: Canada ages, Catalogue no. 96F0030XIE2001002, 2002, p. 14.

11. For an explanation of random rounding see Statistics Canada, 2001 Census Dictionary, Ottawa: Ministry of Industry, 2002, p. 296.

¹² In addition to the incomplete enumeration of Aboriginal communities, occasionally Statistics Canada miscounts populations. When this is discovered, adjusted population numbers are listed separately from the former numbers. Three communities in Northern Ontario were miscounted



SIOUX-LOOKOUT HYDRO INC.

by Statistics Canada in 2001. They are Greenstone, Moosonee, and Cochrane, Unorganized, North Part. Because of the uncertainty surrounding these miscounts, the adjusted figures are not included in this analysis. Statistics Canada indicates that it underestimated the 2001 population of Cochrane, Unorganized, North Part by 262 people. It claims to have underestimated the 2001 population of Moosonee by 980 and Greenstone by 245.

¹³ Information for this section is based largely on analysis done by Statistics Canada and contained in the document, Statistics Canada, Portrait of the Canadian Population in 2006, 2006 Census, 2006 Census Analysis Series, Catalogue no. 97-550-XIE, March, 2007.

¹⁴ Statistics Canada, Portrait of the Canadian Population in 2006, 2006 Census, 2006 Census Analysis Series, Catalogue no. 97-550-XIE, March, 2007, p. 21.

¹⁵ Ibid, p. 35.

16. This number excludes one Aboriginal community which was not properly enumerated in either 2006 or 2001: Bear Island 1 in the District of Nipissing. Note that it also excludes the Muskoka District Municipality.

¹⁷ This number excludes six Aboriginal communities which were not properly enumerated in either 2001 or 1996.

18. Northern Manitoba is defined as census divisions 19, 21, 22, and 23. Northern Saskatchewan is defined as census divisions 14, 15, 16, 17, and 18. Northern Alberta is defined as census divisions 12, 13, 16, 17, 18, and 19.

19. These figures include the adjusted figures for the change from 1996 to 2001 that were mentioned in the text. The figures for the other census years were not adjusted.

20. Statistics Canada, A Profile of the Canadian Population: Where We Live, Ottawa, 2001, p.8.



File Number: EB-2007-0785

Exhibit: 3

Tab: 2

Schedule: 2

Page: 73

SIOUX-LOOKOUT HYDRO INC.

Appendix A



SIOUX-LOOKOUT HYDRO INC.

Census Sub-divisions of Northern Ontario by Change in Population

from 2001 to 2006

Community	Local Board	Type of Community	Population in 2006	% Change Population
Nipissing, Unorganized, South Part	20 1019,6	NO	571	
Saug-a-Gaw-Sing 1	25 910	IRI	101	
Muskrat Dam Lake	25 313,1	IRI	252	
Fort Albany (Part) 67	23 309,3	IRI	1805	
Kenora 38B	25 194,1	IRI	350	
Kitchenuhmaykoosib	25 110,6	IRI	916	
Aaki 84 (Big Trout Lake)				
Whitefish Bay 34A	25 104,3	IRI	94	
Wabaseemoong	25 102,6	IRI	786	
Rat Portage 38A	25 73,6	IRI	316	
Wabauskang 21	25 66,7	IRI	85	
Zhiibaahaasing 19A	21 52,9	IRI	52	
(Cockburn Island 19A)				
Fort William 52	24 51,8	IRI	909	
Whitefish River (Part)	21 41,4	IRI	379	
4 English River 21	25	IRI	633	



SIOUX-LOOKOUT HYDRO INC.

	39,4			
Rainy Lake 26A	25	IRI	128	
	37,6			
The Dalles 38C	25	IRI	156	
	32,2			
Sheguiandah 24	21	IRI	160	
	32,2			
Summer Beaver	24	S-É	362	
	31,2			
Mattawan	20	TP	147	
	28,9			
Parry Sound,	20	NO	236	
	27,6			
Unorganized, North East Part				
Bearskin Lake	25	IRI	459	
	26,4			
Neguaguon Lake 25D	25	IRI	257	
	24,2			
Lake of Bays	20	TP	3570	
	23,1			
Osnaburgh 63B	25	IRI	347	
	22,6			
Poplar Hill	25	IRI	457	
	22,5			
Matachewan	23	TP	375	
	21,8			
Sheshegwaning 20	21	IRI	107	
	21,6			
Pays Plat 51	24	IRI	79	
	21,5			
Latchford	23	T	446	
	21,2			
Whitestone	20	MU	1030	
	20,8			
Pickle Lake	25	TP	479	
	20,1			
Magnetawan	20	MU	1610	20
Kee-Way-Win	25	IRI	318	20
Wunnumin 1	25	IRI	487	
	19,7			



SIOUX-LOOKOUT HYDRO INC.

Manitou Rapids 11	25	IRI	228	
	19,4			
Cochrane, Unorganized, South East Part	23	NO	25	19
Seine River 23A	25	IRI	272	
	18,3			
Shuniah	24	TP	2913	
	18,1			
Matachewan 72	23	IRI	72	18
Georgian Bay	20	TP	2340	
	17,5			
Nairn and Hyman	21	TP	493	
	17,4			
Rainy Lake 18C	25	IRI	95	
	17,3			
Lac Seul 28	25	IRI	821	17
Sioux Narrows -	25	TP	672	
	16,5			
Nestor Falls				
Couchiching 16A	25	IRI	691	
	16,1			
Big Grassy River	25	IRI	204	
	15,9			
35G				
McKellar	20	TP	1080	
	15,8			
Seguin	20	TP	4276	
	15,6			
Mississagi River 8	22	IRI	414	15
Cat Lake 63C	25	IRI	492	15
Garden River 14	22	IRI	985	
	14,7			
Peawanuck	23	S-É	221	
	14,5			
Fort Hope 64	24	IRI	1144	
	14,3			
The Archipelago	20	TP	576	
	14,1			
Mattagami 71	23	IRI	189	
	13,9			
Bracebridge	20	T	15652	
	13,8			
Kingfisher Lake 1	25	IRI	415	



SIOUX-LOOKOUT HYDRO INC.

	12,8			
Sabaskong Bay 35D	25	IRI	390	
	12,7			
Moose Point 79	20	IRI	208	
	12,4			
North Spirit Lake	25	IRI	259	
	12,1			
Sucker Creek 23	21	IRI	346	
	11,6			
Shawanaga 17	20	IRI	193	
	10,9			
Pic River 50	24	IRI	383	
	10,7			
Whitefish Bay 33A	25	IRI	53	
	10,4			
Parry Sound,	20	NO	2424	
	10,3			
Unorganized, Centre Part				
Eagle Lake 27	25	IRI	232	10
Long Lake 58	24	IRI	417	9,2
Manitoulin,	21	NO	222	8,8
Unorganized, West Part				
Ryerson	20	TP	686	8,5
Sandy Lake 88	25	IRI	1843	8,2
Moonbeam	23	TP	1298	8,1
Chisholm	20	TP	1318	7,2
Northeastern	21	T	2711	7,1
Manitoulin and the Islands				
Muskoka Lakes	20	TP	6467	7

3

2



SIOUX-LOOKOUT HYDRO INC.

Red Lake	25	MU	4526	6,9
Magnetewan 1	20	IRI	78	6,8
Macdonald, Meredith and Aberdeen Additional	22	TP	1550	6,7
Neebing	24	MU	2184	6,6
Johnson	22	TP	701	6,5
Wapekeka 2	25	IRI	350	6,4
Killarney	21	MU	454	6,1
Papineau-Cameron	20	TP	1058	6,1
Wahnapeitei 11	21	IRI	52	6,1
Thunder Bay, Unorganized	24	NO	6585	5,8
Nipissing	20	TP	1642	5,7
Carling	20	TP	1123	5,6
Laird	22	TP	1078	5,6
Huntsville	20	T	18280	5,4
Serpent River 7	22	IRI	340	5,3
Slate Falls	25	S-É	164	5,1
M'Chigeeng 22 (West Bay 22)	21	IRI	766	5,1
Whitefish Lake 6	21	IRI	349	4,8
Shoal Lake (Part) 39A	25	IRI	346	4,8
Temagami	20	MU	934	4,6
Gillies	24	TP	544	4,2
Tehkummah	21	TP	382	4,1
Gauthier	23	TP	133	3,9
McDougall	20	MU	2704	3,7
Lake Helen 53A	24	IRI	283	3,3
McMurrich/Monteith	20	TP	791	3,3
Kearney	20	T	798	3,2
Gore Bay	21	T	924	2,9
South River	20	VL	1069	2,8
Nipissing 10	20	IRI	1413	2,5
North Bay	20	CY	53966	2,3
Callander	20	MU	3249	2,3
Webequie	24	IRI	614	2,3
West Nipissing / Nipissing Ouest	20	M	13410	2,3
Machar	20	TP	866	2
Central Manitoulin	21	TP	1944	1,9
Powassan	20	MU	3309	1,8



SIOUX-LOOKOUT HYDRO INC.

Greater Sudbury / Grand Sudbury	21	C	157857	1,7
Sachigo Lake 1	25	IRI	450	1,6
Sagamok	22	IRI	884	1,6
Gravenhurst	20	T	11046	1,3
Dawson	25	TP	620	1,1
Temiskaming Shores	23	CY	10732	1

3

3

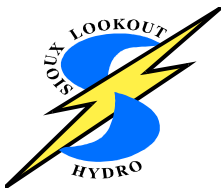

SIOUX-LOOKOUT HYDRO INC.

North Shore	22	TP	549	0,9
Calvin	20	TP	608	0,8
Sault Ste. Marie	22	CY	74948	0,5
Weagamow Lake 87	25	IRI	700	0,4
Ear Falls	25	TP	1153	0,3
Alberton	25	TP	958	0,2
Thunder Bay	24	CY	109140	0,1
Henvey Inlet 2	20	IRI	15	0
Cobalt	23	T	1229	0
Dryden	25	CY	8195	0
Sables-Spanish	21	TP	3237	
	-0,2			
Rivers				
Dokis 9	20	IRI	195	
	-0,5			
La Vallee	25	TP	1067	
	-0,6			
O'Connor	24	TP	720	
	-0,6			
Harley	23	TP	551	
	-1,1			
Chapleau 75	23	IRI	92	
	-1,1			
Conmee	24	TP	740	
	-1,1			
Hilton Beach	22	VL	172	
	-1,1			
Harris	23	TP	512	
	-1,2			
Wikwemikong	21	IRI	2387	
	-1,6			
Unceded				
Timmins	23	CY	42997	
	-1,6			
Oliver Paipoonge	24	MU	5757	
	-1,8			
Assiginack	21	TP	914	
	-1,8			
South Algonquin	20	TP	1253	-2
Emo	25	TP	1305	-2
Timiskaming, Unorganized, West Part	23	NO	3205	-2
Lake of the Woods	25	TP	323	

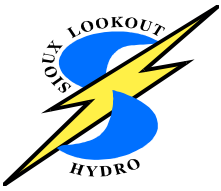

SIOUX-LOOKOUT HYDRO INC.

	-2,1		
East Ferris	20	TP	4200
	-2,1		
Billings	21	TP	539
	-2,2		
Fort Frances	25	T	8103
	-2,5		
Espanola	21	T	5314
	-2,5		
Bonfield	20	TP	2009
	-2,7		
Constance Lake 92	23	IRI	702
	-2,9		
Sioux Lookout	25	MU	5183
	-2,9		
Strong	20	TP	1327
	-3,1		
Nipissing,	20	NO	1798
	-3,1		
Unorganized, North Part			
Elliot Lake	22	CY	11549
	-3,4		
Joly	20	TP	280
	-3,4		
Hearst	23	T	5620
	-3,5		
Cochrane	23	T	5487
	-3,6		
Prince	22	TP	971
	-3,9		
Wabigoon Lake 27	25	IRI	147
	-3,9		
Sundridge	20	VL	942
	-4,2		
Kenora	25	CY	15177
	-4,2		



SIOUX-LOOKOUT HYDRO INC.

Kirkland Lake	23	T	8248	
	-4,3			
Blind River	22	T	3780	
	-4,8			
Parry Sound	20	T	5818	-5
Burk's Falls	20	VL	893	-5
Thessalon	22	T	1312	
	-5,3			
French River /	21	M	2659	
	-5,4			
Rivière des Français				
Huron Shores	22	MU	1696	
	-5,5			
Armstrong	23	TP	1155	
	-5,6			
Hilton	22	TP	243	
	-5,8			
Armour	20	TP	1249	
	-5,8			
Markstay-Warren	21	MU	2475	
	-5,8			
Chapple	25	TP	856	
	-5,9			
Barrie Island	21	TP	47	-6
St. Joseph	22	TP	1129	-6
Aroland 83	24	IRI	325	
	-6,1			
Rainy River,	25	NO	1431	
	-6,2			
Unorganized				
Englehart	23	T	1494	
	-6,3			
Evanturel	23	TP	473	
	-6,5			
Algoma,	22	NO	5717	
	-6,5			
Unorganized, North				
Part				
Morley	25	TP	492	
	-6,5			
Parry Island First	20	IRI	350	
	-6,7			
Nation				
Plummer Additional	22	TP	625	



SIOUX-LOOKOUT HYDRO INC.

	-6,9			
St.-Charles	21	MU	1159	
	-6,9			
Bruce Mines	22	T	584	
	-6,9			
Jocelyn	22	TP	277	-7
Larder Lake	23	TP	735	-7
Rainy River	25	T	909	
	-7,3			
Chamberlain	23	TP	322	
	-7,5			
Kenora, Unorganized	25	NO	7041	
	-7,7			
Hilliard	23	TP	222	
	-7,9			
Kapuskasing	23	T	8509	
	-7,9			
Kasabonika Lake	25	IRI	681	-8
Val Rita-Harty	23	TP	939	
	-8,1			
Rainy Lake 17A	25	IRI	183	
	-8,5			
Casey	23	TP	385	
	-8,6			
Thessalon 12	22	IRI	112	
	-8,9			
Burpee and Mills	21	TP	329	
	-9,1			
Black River-	23	TP	2619	
	-9,3			
Matheson				
Atikokan	25	TP	3293	
	-9,3			
Iroquois Falls	23	T	4729	
	-9,4			
Kerns	23	TP	325	
	-9,7			
Deer Lake	25	IRI	681	
	-9,9			
Shoal Lake 34B2	25	IRI	126	-10
Abitibi 70	23	IRI	114	-
10,2				



SIOUX-LOOKOUT HYDRO INC.

Perry 10,7	20	TP	2010	-
Spanish 10,8	22	T	728	-
Nipigon 10,8	24	TP	1752	-
Baldwin 11,2	21	TP	554	-
Hornepayne 11,2	23	TP	1209	-
James 11,3	23	TP	414	-
Gros Cap 49 11,5	22	IRI	54	-
Mattawa 11,8	20	T	2003	-
Thornloe 12,5	23	VL	105	-
Marathon 12,5	24	T	3863	-
Michipicoten 12,6	22	TP	3204	-
Charlton and Dack 12,7	23	MU	613	-
Gordon 12,9	21	TP	412	-
Greenstone 13,3	24	MU	4906	-
Mattice-Val Côté 13,4	23	TP	772	-
Opasatika 13,8	23	TP	280	-
Red Rock 13,8	24	TP	1063	-
Dorion 14,3	24	TP	379	-
McGarry 14,4	23	TP	674	-
Machin 14,4	25	TP	978	-
White River 15,3	22	TP	841	-
Fauquier-Strickland 16,2	23	TP	568	-



SIOUX-LOOKOUT HYDRO INC.

Ignace 16,3	25	TP	1431	-
Tarbutt and Tarbutt 16,7	22	TP	388	-
Additional Terrace Bay 16,7	24	TP	1625	-
Chapleau 16,9	23	TP	2354	-
Sudbury, Unorganized, North Part	21	NO	2415	-17
Pic Moberth North	24	IRI	137	-18
Osnaburgh 63A 18,2	24	IRI	153	-
French River 13 18,2	20	IRI	99	-
Gull River 55 18,3	24	IRI	206	-
Smooth Rock Falls 19,5	23	T	1473	-
Dubreuilville 20,1	22	TP	773	-
Coleman 21,6	23	TP	431	-
Rocky Bay 1 21,8	24	IRI	154	-
Manitouwadge	24	TP	2300	-22
Duck Lake 76B 23,4	21	IRI	82	-
Ginoogaming First Nation 24,2	24	IRI	175	-
Brethour 25,5	23	TP	117	-
Pic Moberth South 25,7	24	IRI	104	-
New Post 69A 30,5	23	IRI	73	-
Long Sault 12 31,3	25	IRI	33	-
Wawakapewin (Long Dog Lake) 32,3	25	IRI	21	-
Hudson 37,8	23	TP	305	-
Schreiber 37,8	24	TP	901	-



File Number: EB-2007-0785

Exhibit: 3

Tab: 2

Schedule: 2

Page: 86

SIoux-LOOKOUT HYDRO INC.



SIOUX-LOOKOUT HYDRO INC.

Chapleau 74A	23	IRI	20	-
39,4				
Lake Of The Woods	25	IRI	58	-
41,4				
37				
Northwest Angle 33B	25	IRI	40	-
58,8				
Big Island Mainland	25	IRI	10	-
88,2				
93				
Lansdowne House	24	S-É	0	-
100				
Rankin Location 15D	22	IRI	566	
Fort Albany (Part) 67	25	IRI	5	
Algoma,	22	NO	0	
Unorganized, South				
East Part				
Whitefish River (Part)	21	IRI	0	
4				
Missanabie 62	22	IRI	0	
MacDowell Lake	25	S-É	0	
Rainy Lake 17B	25	IRI	5	
Marten Falls 65	25	IRI	221	
Goulais Bay 15A	22	IRI	82	
Sabaskong Bay	25	IRI	0	
(Part) 35C				
Whitesand	24	IRI	247	
Agency 1	25	IRI	0	
Seine River 22A2	24	IRI	0	
Seine River 23B	25	IRI	0	
Pikangikum 14	25	IRI	2100	
Fort Severn 89	25	IRI	467	
Lake Of The Woods	25	IRI	0	
31G				
Manitoulin,	21	NO	5	
Unorganized,				
Mainland				
Sabaskong Bay	25	IRI	0	
(Part) 35C				
Ojibway Nation of	24	IRI	98	
Saugeen (Savant				
Lake)				
Cockburn Island	21	TP	10	
Sachigo Lake 2	25	IRI	0	



SIOUX-LOOKOUT HYDRO INC.

Lac des Mille Lacs 22A1	24	IRI	21
Timiskaming, Unorganized, East Part	23	NO	10
Shoal Lake (Part) 40	25	IRI	105
Attawapiskat 91A	23	IRI	1506
Mountbatten 76A	23	IRI	0
Cochrane, Unorganized, North Part	23	NO	2447

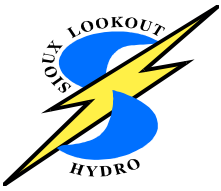
**SIOUX-LOOKOUT HYDRO INC.**

Neskantaga	25	IRI	265
Cochrane, Unorganized, South West Part	23	NO	0
Naiscoutaing 17A	20	IRI	0
New Post 69	23	IRI	0
Moosonee	23	TV	2006
Wapekeka 1	25	IRI	0
Moose Factory 68	23	IRI	0
Zhiibaahaasing 19 (Cockburn Island 19)	21	IRI	0
Factory Island 1	23	IRI	1666
Whitefish Bay 32A	25	IRI	622
Flying Post 73	23	IRI	40
Bear Island 1	20	IRI	
Wahta Mohawk Territory	20	IRI	
Wunnumin 2	25	IRI	0



SIOUX-LOOKOUT HYDRO INC.

NORMALIZED VOLUME FORECAST TABLE

	2006 Board Approved	2006 Actual Normalized	Variance form 2006 Board Approved	2006 Actual Normalized	2007 Bridge Normalized	Variance form 2006 Actual Normalized	2007 Bridge Normalized	2008 Test Normalized	Variance form 2007 Actual
Residential	32,478,156	33,318,949	840,793	33,318,949	33,377,072	58,123	33,377,072	33,435,195	58,123
GS < 50 kW	19,083,747	15,941,009	(3,142,737)	15,941,009	15,941,009	0	15,941,009	15,941,009	0
GS Interval Meters >50 - 5000 kW (kWh)	41,418,697	47,204,514	5,785,817	47,204,514	47,204,514	0	47,204,514	48,328,431	1,123,917
GS Interval Meters >50 - 5000 kW (kW)	110,498	111,593	1,095	111,593	118,251	6,658	118,251	121,066	2,815
Street Lighting (kWh)	465,217	488,766	23,549	488,766	478,103	-10,663	478,103	477,656	-447
Street Lighting (kW)	1,475	1,449	(26)	1,449	1,477	28	1,477	1,475	-1
USL	30,761	24,781	(5,980)	24,781	24,781	0	24,781	24,781	0

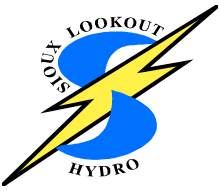

SIOUX-LOOKOUT HYDRO INC.

CUSTOMER COUNT FORECAST TABLE

Year	2002	2003	2004	2005	2006	2007	2007N	2008
Residential	2279	2274	2287	2300	2293	2297	2297	2301
GS < 50	423	417	414	423	399	399	399	399
GS Interval Meters >50 - 5000 kW	27	32	35	37	42	42	42	43
Street Lighting	535	535	537	532	533	533	533	533
USL	10	12	12	12	12	12	12	12



SIOUX-LOOKOUT HYDRO INC.

HISTORICAL AVERAGE CONSUMPTION

HISTORICAL AVERAGE CONSUMPTION

Residential

<u>Year</u>	<u>Weather Actual</u>	<u>Weather Normalized</u>	<u>Difference</u>	<u>%Difference</u>
2002	31,422,729.00	N/A		
2003	32,459,023.00	N/A		
2004	33,256,852.00	N/A		
2005	32,820,792.00	N/A		
2006	31,452,628.00	33,318,949.06	1,866,321.06	
2007	31,507,495.21	33,377,071.95	1,869,576.74	
2008	N/A	33,435,194.85		

GS < 50 kW

<u>Year</u>	<u>Weather Actual</u>	<u>Weather Normalized</u>	<u>Difference</u>	<u>%Difference</u>
2002	24,047,952.00	N/A		
2003	16,706,469.00	N/A		
2004	16,558,782.00	N/A		
2005	16,188,511.00	N/A		
2006	14,960,770.00	15,941,009.21	980,239.21	
2007	14,567,491.74	15,521,963.11	954,471.37	
2008	N/A	15,113,932.59		

GS Interval Meters >50 - 5000 KWh

<u>Year</u>	<u>Weather Actual</u>	<u>Weather Normalized</u>	<u>Difference</u>	<u>%Difference</u>
2002	30,314,028.00	N/A		
2003	41,705,351.00	N/A		
2004	39,344,901.00	N/A		
2005	44,891,158.00	N/A		
2006	45,150,837.00	47,204,514.22	2,053,677.22	
2007	50,525,936.64	52,824,099.25	2,298,162.60	
2008	N/A	58,443,684.27		

GS Interval Meters >50 - 5000 kW

<u>Year</u>	<u>Weather Actual</u>	<u>Weather Normalized</u>	<u>Difference</u>	<u>%Difference</u>
2002	95,145.00	N/A		
2003	103,564.00	N/A		
2004	94,884.00	N/A		
2005	104,253.00	N/A		
2006	106,738.00	111,592.96	4,854.96	
2007	126,571.26	132,328.33	5,757.07	
2008	N/A	146,405.81		



SIOUX-LOOKOUT HYDRO INC.

Street Lights (KWh)

<u>Year</u>	<u>Weather Actual</u>	<u>Weather Normalized</u>	<u>Difference</u>	<u>%Difference</u>
2002	457,184.00	N/A		
2003	464,827.00	N/A		
2004	470,192.00	N/A		
2005	492,941.00	N/A		
2006	488,766.00	488,766.00	-	
2007	488,766.00	478,103.00	(10,663.00)	
2008	N/A	477,656.00		

Street Lights (KW)

<u>Year</u>	<u>Weather Actual</u>	<u>Weather Normalized</u>	<u>Difference</u>	<u>%Difference</u>
2002	1,489.97	N/A		
2003	1,462.00	N/A		
2004	1,461.00	N/A		
2005	1,470.00	N/A		
2006	1,449.00	1,449.00	-	
2007	1,510.00	1,477.00	(33.00)	
2008	N/A	1,475.00		



SIOUX-LOOKOUT HYDRO INC.

OTHER DISTRIBUTION REVENUE

OTHER DISTRIBUTION REVENUE	2006 Board Approved	2006 Actual	Variance form 2006 Board Approved	2006 Actual	2007 Actual	Variance form 2006 Actual	2007 Bridge	2008 Test	Variance form 2007 Actual
	(\$'s)	(\$'s)	(\$'s)	(\$'s)	(\$'s)				
Other Distribution Revenue									
4225-Late Payment Charges	50,517.00	54,829.00	4,312.00	54,829.00	54,000.00	(829.00)	54,000.00	54,000.00	-
4235-Miscellaneous Service Revenues	50,231.00	20,122.00	(30,109.00)	20,122.00	20,122.00	-	20,122.00	20,122.00	-
4210-Rent from Electric Property	16,367.00	42,027.00	25,660.00	42,027.00	42,027.00	-	42,027.00	42,027.00	-
4390-Miscellaneous Non-Operating Income	9,864.00	13,404.00	3,540.00	13,404.00	13,404.00	-	13,404.00	13,404.00	-
4405-Income from Dividend	25,311.00	43,017.00	17,706.00	43,017.00	43,000.00	(17.00)	43,000.00	45,000.00	2,000.00
4360-Loss on Disposition of Utility and Other Property	(3,329.00)	(825.00)	2,504.00	(825.00)	(825.00)	-	(825.00)	(825.00)	-
	148,961.00	172,574.00	23,613.00	172,574.00	171,728.00	(846.00)	171,728.00	173,728.00	2,000.00

**SIOUX-LOOKOUT HYDRO INC.****MATERIALITY ANALYSIS ON OTHER DISTRIBUTION REVENUES****2006 Board Approved VS 2006 Actual**

Asset Account	2006 Bridge	2008 Test	Variance
4225-Late Payment Charges	50,517.00	54,829.00	4,312.00

The amount for the 2006 Board Approved is based on 2004 data

Asset Account	2006 Bridge	2008 Test	Variance
4235-Miscellaneous Service Revenues	50,231.00	20,122.00	(30,109.00)
Asset Account	2006 Bridge	2008 Test	Variance
4210- Rent from Electric Property	16,367.00	42,027.00	25,660.00

The variances for account 4235 and 4210 are due to different allocations used for the 2006 Board approved amounts and the 2006 Actual. Account 4235 includes pole rental revenue for the Board Approved amounts. The pole rental revenue for the 2006 Actual is included in account 4210.

Asset Account	2006 Bridge	2008 Test	Variance
4390-Miscellaneous Non-Operating Income	9,864.00	13,404.00	3,540.00

The 2006 Board Approved amount for account 4390 is based on 2004 data.

Asset Account	2006 Bridge	2008 Test	Variance
4405-Income from Interest and Dividends	25,311.00	43,017.00	17,706.00

The 2006 Board Approved amount for account 4405 is based on 2004 data. SLHI receives interest on its bank account balance of prime less 2%. There was a significant increase in the prime rate of interest from 2004 to 2006.

Asset Account	2006 Bridge	2008 Test	Variance
4360-Loss on Disposition of Utility and Other Property	(3,329.00)	(825.00)	2,504.00

There were few disposals in 2006.



SIOUX-LOOKOUT HYDRO INC.

2006 Actual VS 2007 Bridge

Asset Account	2006 Bridge	2008 Test	Variance
4405-Income from Dividend	43,000.00	45,000.00	2,000.00

The variance of \$2000 is explained through normal inflation projections.

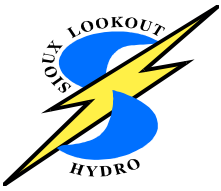

SIOUX-LOOKOUT HYDRO INC.

RATE OF RETURN ON OTHER DISTRIBUTION REVENUES

In this application, Sioux Lookout Hydro Inc. has applied for the same Specific Service Charges schedule previously approved in the 2007 Tariffs of Rates and Charges (EB-2007-0576). The Specific Service Charges schedule follows the OEB recommended charges and as such Sioux Lookout Hydro Inc. has no further information related to the rate of return on non-core delivery activities.



SIOUX-LOOKOUT HYDRO INC.

DISTRIBUTION REVENUE DATA

DISTRIBUTION REVENUE DATA					
	<u>2006 Board Approved</u>				
	Customers	Consumption	Consumption	Distribution Revenues	Unit Revenues
	(Year-End)	(kWh)	(KW)	(\$)	\$/kWh
Residential	2,287.00	32,478,156.42		832,450.80	0.0256
GS < 50 kW	414.00	19,083,746.69		305,307.54	0.0160
GS Interval Meters >50 - 5000 kW	35.00	41,418,696.96	110,497.75	330,323.26	0.0080
Street Lighting	537.00	465,216.59	1,474.67	8,918.70	0.0192
USL	12.00	30,761.33		2,751.43	0.0894
TOTAL	3,285.00	93,476,577.99	111,972.41	1,479,751.73	0.0158
	<u>2006 Actual</u>				
	Customers	Consumption	Consumption	Distribution Revenues	Unit Revenues
	(Year-End)	(kWh)	(KW)	(\$)	\$/kWh
Residential	2,293.00	31,452,628.00		825,049.76	0.0262
GS < 50 kW	399.00	14,960,770.00		271,261.66	0.0181
GS Interval Meters >50 - 5000 kW	42.00	45,150,837.00	106,738.00	396,387.91	0.0088
Street Lighting	533.00	488,766.00	1,449.00	8,852.26	0.0181
USL	12.00	24,781.00		2,713.16	0.1095
TOTAL	3,279.00	92,077,782.00	108,187.00	1,504,264.75	0.0163
	<u>2006 Actual - Normalized</u>				
	Customers	Consumption	Consumption	Distribution Revenues	Normalized Consumption
	(Year-End)	(kWh)	(KW)	(\$)	(kWh / KW)
Residential	2,293.00	33,318,949.06		1,085,313.83	0.0326
GS < 50 kW	399.00	15,941,009.21		354,504.21	0.0222
GS Interval Meters >50 - 5000 kW	42.00	47,204,514.22	111,592.96	613,218.22	0.0130
Street Lighting	533.00	488,766.00	1,449.00	12,591.60	0.0258
USL	12.00	24,781.00		6,444.55	0.2601
TOTAL	3,279.00	96,978,019.50	113,041.96	2,072,072.42	0.0214



SIOUX-LOOKOUT HYDRO INC.

2007 Bridge - Normalized					
	Customers	Consumption	Consumption	Distribution	Normalized
	(Year-End)	(kWh)	(KW)	Revenues	Consumption
				(\$)	(kWh / KW)
Residential	2,297.00	33,377,071.95		849,929.73	0.0255
GS < 50 kW	389.00	15,521,963.11		273,830.75	0.0176
GS Interval Meters >50 - 5000 kW	47.00	52,824,099.25	132,328.33	447,563.68	0.0085
Street Lighting	533.00	478,103.14	1,476.66	8,928.07	0.0187
USL	12.00	24,781.00		2,746.11	0.1108
TOTAL	3,278.00	102,226,018.44	133,804.99	1,582,998.34	0.0155
2008 Test - Normalized					
	Customers	Consumption	Consumption	Distribution	Unit
	(Year-End)	(kWh)	(KW)	Revenues	Revenues
				(\$)	\$/kWh
Residential	2,301.00	33,435,194.85		1,093,936.45	0.0327
GS < 50 kW	378.00	15,113,932.59		355,192.17	0.0235
GS Interval Meters >50 - 5000 kW	52.00	58,443,684.27	146,405.81	687,391.41	0.0118
Street Lighting	533.00	477,655.68	1,475.28	11,651.33	0.0244
USL	12.00	24,781.00		3,227.07	0.1302
TOTAL	3,276.00	107,495,248.40	147,881.09	2,151,398.43	0.0200



File Number: EB-2007-0785

Exhibit: 3

Tab: 4

Schedule: 1

Page: 1

SIOUX-LOOKOUT HYDRO INC.

DESCRIPTION OF REVENUE SHARING

Sioux Lookout Hydro Inc does not engage in revenue sharing.

**SIOUX-LOOKOUT HYDRO INC.**

<u>Ex.</u>	<u>Tab</u>	<u>Schedule</u>	<u>Contents of Schedule</u>
<u>4 - Operating Costs</u>			
	1		Overview
		1	Overview of Operating Costs
		2	Summary of Operating Costs Table
	2		OM&A Costs
		1	OM&A Costs Table
		2	Variance Analysis on OM&A Costs Table
		3	Materiality Analysis on OM&A Costs
		4	Shared Services
		5	Corporate Cost Allocation
		6	Purchase of Services
		7	Employee Description
		8	Depreciation, Amortization and Depletion
		9	Loss Adjustment Factor Calculation
		10	Materiality Analysis on Distribution Losses
		11	Retail Transmission Adjustment
	3		Income Tax, Large Corporation Tax
		1	Tax Calculations
		2	Capital Cost Allowance (CCA)



SIOUX-LOOKOUT HYDRO INC.

OVERVIEW OF OPERATING COSTS

Operating Costs

The operating costs presented in this exhibit represent the annual expenditures required for to sustain The Applicant's Distribution Operations. The information presented in this exhibit is grouped into two different categories: Operation & Maintenance and Other Costs which include items such as Administration & General, Sales Promotion & Customer Accounting, Depreciation, Amortization and Depletion, Shared Services and Loss Adjustment Factor.

The second category includes Income Tax, Large Corporation Tax and Ontario Capital Taxes. Exhibit 4, Tab 3, Schedule 1 provides a summary of The Applicant's Operating Costs for the historical, bridge and test years.

OM&A Costs

The OM&A costs in this exhibit represents The Applicant's integrated set of asset maintenance and customer activity needs to meet public and employee safety objectives; to comply with the Distribution System Code, environmental requirements and Government direction; and to maintain distribution business service quality and reliability at targeted performance levels. These costs also include providing services to customers connected to the Applicant's Distribution system, and to meet the service levels stipulated in the Standard Supply Service Code and the Retailer Settlement Codes.

The proposed OM&A cost expenditures for the 2008 test year result from a rigorous business planning and work prioritization process that reflects risk-based decision making to ensure that the most appropriate, cost effective solutions are put in place.

OM&A expenditures totaled \$1,152,235.42 million in 2006 Board Approved, \$1,619,295.04 million in 2006 Actual and are forecast to be \$1,779,004.00 million in 2007 and \$1,809,086.00 million in 2008.



SIoux-LOOKOUT HYDRO INC.

Income Tax, Large Corporation Tax and Ontario Capital Taxes

This information consists of detailed calculations of income taxes, and indemnity payments to the Province. Details of the expenditures are filed at Exhibit 4, Tab 3, Schedule 1.

The Income Taxes, Large Corporation Taxes and Ontario Capital Taxes expenditures are forecasted to be \$22,108 in 2007 and \$ 52,134 in 2008.



SIOUX-LOOKOUT HYDRO INC.

SUMMARY OF OPERATING COSTS TABLE

SUMMARY OF OM&A COSTS	2006 Board Approved	2006 Actual	Variance form 2006 Board Approved	% change	2006 Actual	2007 Bridge	Variance form 2006 Actual	% change	2007 Bridge	2008 Test	Variance form 2007 Bridge	% change
Operation (Working Capital)	337,710.31	340,553.04	2,842.73	0.84	340,553.04	402,439.00	61,885.96	18.17	402,439.00	421,827.00	19,388.00	4.82
Maintenance (Working Capital)	89,818.63	72,867.00	(16,951.63)	(18.87)	72,867.00	90,755.00	17,888.00	24.55	90,755.00	87,281.00	(3,474.00)	(3.83)
Billing and Collections	242,156.51	298,055.00	55,898.49	23.08	298,055.00	307,814.00	9,759.00	3.27	307,814.00	346,826.00	39,012.00	12.67
Community Relations	-	2,218.00	2,218.00	-	2,218.00	-	(2,218.00)		-	-	-	
Bad Debt	2,813.92	51,740.00	48,926.08	1,738.72	51,740.00	40,000.00	(11,740.00)	(22.69)	40,000.00	20,000.00	(20,000.00)	(50.00)
Property Insurance	25,445.93	25,728.00	282.07	1.11	25,728.00	26,176.00	448.00	1.74	26,176.00	26,700.00	524.00	2.00
General Advertising Expenses	785.00	546.00	(239.00)	(30.45)	546.00	800.00	254.00	46.52	800.00	1,000.00	200.00	25.00
Taxes Other Than Income Taxes	7,466.00	8,675.00	1,209.00		8,675.00	8,700.00	25.00	0.29	8,700.00	8,700.00	-	
Administrative and General Expenses	222,888.12	246,991.00	24,102.88	10.81	246,991.00	251,308.00	4,317.00	1.75	251,308.00	233,192.00	(18,116.00)	(7.21)
Amortization Expenses	223,151.00	232,779.00	9,628.00	4.31	232,779.00	311,012.00	78,233.00	33.61	311,012.00	323,104.00	12,092.00	3.89
4750-LV Charges	-	339,143.00	339,143.00	-	339,143.00	340,000.00	857.00	0.25	340,000.00	340,456.00	456.00	0.13
Total Operating Costs	1,152,235.42	1,619,295.04	467,059.62	40.54	1,619,295.04	1,779,004.00	159,708.96	9.86	1,779,004.00	1,809,086.00	30,082.00	1.69



SIOUX-LOOKOUT HYDRO INC.

5065-Meter Expense	3,862	9,063.75	5,201.63	9,063.75	15,000.00	5,936.25	15,000.00	9,000.00	(6,000.00)
5070-Customer Premises - Operation Labour	-	-	-	-	-	-	-	-	-
5075-Customer Premises - Materials and Expenses	-	-	-	-	-	-	-	-	-
5085-Miscellaneous Distribution Expense	19,860.56	14,106.93	(5,753.63)	14,106.93	15,157.00	1,050.07	15,157.00	20,157.00	5,000.00
5090-Underground Distribution Lines and Feeders - Rental Paid	-	-	-	-	-	-	-	-	-
5095-Overhead Distribution Lines and Feeders - Rental Paid	-	-	-	-	-	-	-	-	-
5096-Other Rent	-	-	-	-	-	-	-	-	-
Sub-Total	337,710.31	340,553.04	2,842.73	340,553.04	402,439.00	61,885.96	402,439.00	421,827.00	19,388.00
									-
Maintenance (Working Capital)									-
5105-Maintenance Supervision and Engineering	-	-	-	-	-	-	-	-	-
5110-Maintenance of Buildings and Fixtures - Distribution Stations	-	-	-	-	-	-	-	-	-
5112-Maintenance of Transformer Station Equipment	-	-	-	-	-	-	-	-	-
5114-Maintenance of Distribution Station Equipment	-	-	-	-	-	-	-	-	-
5120-Maintenance of Poles, Towers and Fixtures	38,478.52	24,923.00	(13,555.52)	24,923.00	25,745.00	822.00	25,745.00	26,517.00	772.00
5125-Maintenance of Overhead Conductors and Devices	-	-	-	-	-	-	-	-	-
5130-Maintenance of Overhead Services	-	-	-	-	-	-	-	40,000.00	40,000.00
5135-Overhead Distribution Lines and Feeders - Right of Way	39,418.81	35,663.00	(3,755.81)	35,663.00	45,000.00	9,337.00	-	-	(45,000.00)
5145-Maintenance of Underground Conduit	-	-	-	-	-	-	-	-	-
5150-Maintenance of Underground Conductors and Devices	-	-	-	-	-	-	-	-	-
5155-Maintenance of Underground Services	-	-	-	-	-	-	-	-	-
5160-Maintenance of Line Transformers	1,463.24	4,436.00	2,972.76	4,436.00	9,414.00	4,978.00	9,414.00	10,000.00	586.00



SIOUX-LOOKOUT HYDRO INC.

5165-Maintenance of Street Lighting and Signal Systems	-	-	-	-	-	-	-	-	-
5170-Sentinel Lights - Labour	-	2,232.00	2,232.00	2,232.00	-	73.00	2,305.00	2,374.00	69.00
5172-Sentinel Lights - Materials and Expenses	-	1,981.00	1,981.00	1,981.00	2,000.00	19.00	2,000.00	2,000.00	-
5175-Maintenance of Meters	10,458.06	3,632.00	(6,826.06)	3,632.00	6,291.00	2,659.00	6,291.00	6,390.00	99.00
5178-Customer Installations Expenses- Leased Property	-	-	-	-	-	-	-	-	-
5185-Water Heater Rentals - Labour	-	-	-	-	-	-	-	-	-
5186-Water Heater Rentals - Materials and Expenses	-	-	-	-	-	-	-	-	-
5190-Water Heater Controls - Labour	-	-	-	-	-	-	-	-	-
5192-Water Heater Controls - Materials and Expenses	-	-	-	-	-	-	-	-	-
5195-Maintenance of Other Installations on Customer Premises	-	-	-	-	-	-	-	-	-
Sub-Total	89,818.63	72,867.00	(16,951.63)	72,867.00	90,755.00	17,888.00	90,755.00	87,281.00	(3,474.00)
Billing and Collections	-	-	-	-	-	-	-	-	-
5305-Supervision	-	-	-	-	-	-	-	-	-
5310-Meter Reading Expense	58,768.36	76,146.00	17,377.64	76,146.00	78,473.00	2,327.00	78,473.00	80,658.00	2,185.00
5315-Customer Billing	115,441.08	152,078.00	36,636.92	152,078.00	159,403.00	7,325.00	159,403.00	179,865.00	20,462.00
5320-Collecting	68,809.79	69,623.00	813.21	69,623.00	69,641.00	18.00	69,641.00	86,006.00	16,365.00
5325-Collecting- Cash Over and Short	(43.52)	(3.00)	40.52	(3.00)	(3.00)	-	(3.00)	(3.00)	-
5330-Collection Charges	(819.20)	211.00	1,030.20	211.00	300.00	89.00	300.00	300.00	-
5340-Miscellaneous Customer Accounts Expenses	-	-	-	-	-	-	-	-	-
Sub-Total	242,156.51	298,055.00	55,898.49	298,055.00	307,814.00	9,759.00	347,814.00	346,826.00	(988.00)
			-			-			-



SIOUX-LOOKOUT HYDRO INC.

6105-Taxes Other Than Income Taxes	7,466.00	8,675.00	1,209.00		8,675.00	8,700.00	25.00		8,700.00	8,700.00	-
Sub-Total	7,466.00	8,675.00	1,209.00		8,675.00	8,700.00	25.00		8,700.00	8,700.00	-
			-				-				-
Administrative and General Expenses			-				-				-
5605-Executive Salaries and Expenses	34,890.49	22,210.00	(12,680.49)		22,210.00	17,500.00	(4,710.00)		17,500.00	18,500.00	1,000.00
5610-Management Salaries and Expenses	82,024.35	83,650.00	1,625.65		83,650.00	77,565.00	(6,085.00)		77,565.00	79,807.00	2,242.00
5615-General Administrative Salaries and Expenses	25,458.91	37,219.00	11,760.09		37,219.00	39,560.00	2,341.00		39,560.00	40,552.00	992.00
5620-Office Supplies and Expenses	8,669.10	8,353.00	(316.10)		8,353.00	8,300.00	(53.00)		8,300.00	8,600.00	300.00
5625-Administrative Expense Transferred Credit	-	-	-		-	-	-		-	-	-
5630-Outside Services Employed	16,278.03	35,205.00	18,926.97		35,205.00	27,683.00	(7,522.00)		27,683.00	30,683.00	3,000.00
5640-Injuries and Damages	-	-	-		-	-	-		-	-	-
5645-Employee Pensions and Benefits	-	-	-		-	-	-		-	-	-
5650-Franchise Requirements	-	-	-		-	-	-		-	-	-
5655-Regulatory Expenses	11,605.75	12,830.00	1,224.25		12,830.00	38,000.00	25,170.00		38,000.00	13,000.00	(25,000.00)
5665-Miscellaneous General Expenses	28,085.05	30,315.00	2,229.95		30,315.00	23,515.00	(6,800.00)		23,515.00	20,815.00	(2,700.00)
5670-Rent	14,965.80	14,966.00	0.20		14,966.00	17,000.00	2,034.00		17,000.00	19,050.00	2,050.00
5675-Maintenance of General Plant	-	-	-		-	-	-		-	-	-
5680-Electrical Safety Authority Fees	910.64	2,243.00	1,332.36		2,243.00	2,185.00	(58.00)		2,185.00	2,185.00	-
5685-Independent Market Operator Fees and Penalties	-	-	-		-	-	-		-	-	-
Sub-Total	222,888.12	246,991.00	24,102.88		246,991.00	-	4,317.00		251,308.00	233,192.00	(18,116.00)
	-	-	-		-	-	-		-	-	-
Amortization Expenses	-	-	-		-	-	-		-	-	-



SIOUX-LOOKOUT HYDRO INC.

5705-Amortization Expense - Property, Plant, and Equipment	223,151.00	232,779.00	9,628.00		232,779.00	-	78,233.00		311,012.00	323,104.00	12,092.00
5710-Amortization of Limited Term Electric Plant		-	-		-	-	-				-
5715-Amortization of Intangibles and Other Electric Plant		-	-		-	-	-				-
5720-Amortization of Electric Plant Acquisition Adjustments		-	-		-	-	-				-
5725-Miscellaneous Amortization		-	-		-	-	-				-
5730-Amortization of Unrecovered Plant and Regulatory Study Costs		-	-		-	-	-				-
5735-Amortization of Deferred Development Costs		-	-		-	-	-				-
5740-Amortization of Deferred Charges		-	-		-	-	-				-
Sub-Total	223,151.00	232,779.00	9,628.00		232,779.00	311,012.00	78,233.00		311,012.00	323,104.00	12,092.00
4750-LV Charges	-	339,143.00	339,143.00		339,143.00	340,000.00	857.00		340,000.00	340,456.00	456.00
Sub-Total	-	339,143.00	339,143.00		339,143.00	340,000.00	857.00		340,000.00	340,456.00	456.00
TOTAL	1,152,235.42	1,619,295.04	467,059.62		1,619,295.04	1,779,004.00	159,708.96		1,779,004.00	1,809,086.00	30,082.00



SIoux-LOOKOUT HYDRO INC.

VARIANCE ANALYSIS ON OM&A COSTS

2008 Test year

The 2008 test year Operating & Maintenance forecast is shown in Exhibit 4, Tab 1, Schedule 2. The total net cost is expected to be \$1,809,086. Net wages and benefits in the amount of \$509,109 make up 28.14% of the total net Operating & Maintenance costs. Administration and General costs total a further 12.89%. Customer Accountings costs accounts for 19.17% of the total Operating and Maintenance costs.

Comparison to Fiscal 2006 Bridge Year

Exhibit4, Tab1, Schedule2 also provides a comparison of the 2008 test year forecast of Operation & Maintenance expenses to that forecast for the 2007 bridge year. Total net Operation & Maintenance costs are forecast to increase by \$30,082 or 1.69%.

2007 Bridge Year

The 2007 bridge year Operating & Maintenance forecast is shown in Exhibit 4, Tab 1, Schedule 2. The total net cost is expected to be \$1,779,004. Net wages and benefits in the amount of \$493,194 make up 27.72% of the total net Operating & Maintenance costs. Administration and General costs total a further 14.12%. Customer Accountings costs accounts for 17.30% of the total Operating and Maintenance costs.

Comparison to 2006 Actual

Exhibit4, Tab1, Schedule2 also provides a comparison of the 2006 Actual year of Operation & Maintenance expenses to that of the 2007 bridge year. Total net Operation & Maintenance costs are forecast to increase by \$159,708 or 9.86%.

2006 Actual

The 2006 Actual year Operating & Maintenance forecast is shown in Exhibit 4, Tab 1, Schedule 2. The total net cost was \$1,619,295. Net wages and benefits in the amount of \$413,419 make up 25.53% of the total net Operating & Maintenance costs. Administration and General costs total a further 15.25%. Customer Accountings costs accounts for 18.40% of the total Operating and Maintenance costs.



SIOUX-LOOKOUT HYDRO INC.

Comparison to 2006 Board Approved

Exhibit4, Tab1, Schedule2 also provides a comparison of the 2006 Board Approved year of Operation & Maintenance expenses to that of the 2006 Actual year. Total net Operation & Maintenance costs are forecast to increase by \$467,059 or 40.54%. This increase is due to the fact that SLHI did not apply to recover any LV charges in its 2006 EDR. This application includes an estimate of \$340,000 in its revenue requirement to be recovered for LV charges. This figure is based on an average of \$28,340 paid for LV charges per month in the 2006 Actual.

2006 Board Approved

The 2007 bridge year Operating & Maintenance forecast is shown in Exhibit 4, Tab 1, Schedule 2.

The total net cost is expected to be \$1,152,235. Net wages and benefits in the amount of \$427,529 make up 37.11% of the total net Operating & Maintenance costs. Administration and General costs total a further 19.34%. Customer Accountings costs accounts for 21.01% of the total Operating and Maintenance costs.

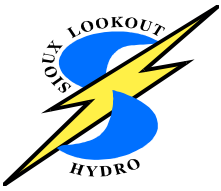
**SIOUX-LOOKOUT HYDRO INC.****MATERIALITY ANALYSIS ON OM&A COSTS****2006 Board Approved VS 2006 Actual**

Asset Account	2006 Board Approved	2006 Actual	Variance
4750- LV Charges	-	339,143.00	339,143.00

This is a new account the OEB created in 2006 to record actual LV charges incurred. There were no such charges in previous years.

2006 Actual VS 2007 Bridge

Asset Account	2006 Actual	2007 Bridge	Variance
5020-Overhead Distribution Lines and Feeders – Operation Labour	236,087.56	296,282.00	60,194.44

During our audit for 2006 fiscal year, the auditor determined that SLHI was carrying a liability for accrued sick leave pay that was too high. There was an credit adjustment applied to account 5020, with the debit being applied to the liability for accrued sick leave. The amount of \$50,729 was added back to this account for the normalized 2006 trial balance.

Asset Account	2006 Actual	2007 Bridge	Variance
5705-Amortization Expense-Property, Plant and Equipment	232,779.00	311,012.00	78,233.00

Depreciation on Transportation Equipment, Office Furniture and Equipment, Computer Equipment, Tools, Measuring and Testing Equipment, Communication Equipment, Power Operated Equipment and Sentinel Lights are recorded in various operating expense general ledger accounts, not account 5705.

The model automatically applies all depreciation to this account, which explains the difference. The following are the 2007 values:

- Office Equipment: \$771
- Tools, Shop & Garage: \$5,099



File Number: EB-2007-0785

Exhibit: 4

Tab: 2

Schedule: 3

Page: 2

SIOUX-LOOKOUT HYDRO INC.

- Measuring & Testing: \$1,369
- Communications Equipment: \$3,079
- Power Operated Equipment: \$13,523
- Transportation Equipment: \$45,661
- Sentinel Lights: \$1,981
- Total: \$71,483

Total subtracted from Variance \$78,233 less \$71,483 is \$6750.



File Number: EB-2007-0785

Exhibit: 4

Tab: 2

Schedule: 4

Page: 1

SIoux-LOOKOUT HYDRO INC.

SHARED SERVICES

Sioux Lookout Hydro does not share any services as they do not have any affiliates.

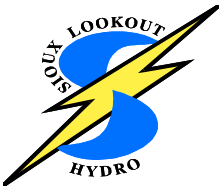

File Number: EB-2007-0785

Exhibit: 4

Tab: 2

Schedule: 5

Page: 1

SIoux-LOOKOUT HYDRO INC.

CORPORATE COST ALLOCATION

Sioux Lookout Hydro does not share any services as they do not have any affiliates and therefore corporate cost allocation does not apply to this Applicant.



SIOUX-LOOKOUT HYDRO INC.

PURCHASE OF SERVICES

	2006 Actual	2007 Bridge	2008 Test
Name of Company transacting with the Applicant	Thunder Bay Hydro Utility Services	Thunder Bay Hydro Utility Services	Thunder Bay Hydro Utility Services
Summary of the nature of the activity transacted	Provide services for wholesale settlements, ebts, handheld meter reading system, remote meter reading functions and customer information system and GMBA(General Ledger) services.	Provide services for wholesale settlements, ebts, handheld meter reading system, remote meter reading functions and customer information system and GMBA(General Ledger) services.	Provide services for wholesale settlements, ebts, handheld meter reading system, remote meter reading functions and customer information system and GMBA(General Ledger) services.
Summary of tendering process/summary of cost approach	On a contract basis. Reviewed yearly. Cost is based on customer count and flat rate fee.	On a contract basis. Reviewed yearly. Cost is based on customer count and flat rate fee.	On a contract basis. Reviewed yearly. Cost is based on customer count and flat rate fee.
Total Annual Expense	\$74,434	\$75,640	\$78,600



SIOUX-LOOKOUT HYDRO INC.

EMPLOYEE DESCRIPTION

Number of employees (Full-time equivalents (FTE's)):

	<u>2006 Board Approved</u>	<u>2006 Actual</u>	<u>2007 Bridge</u>	<u>2008 Test</u>
Executive	1.00	1.00	1.00	1.00
Management	1.00	1.00	1.00	1.00
Non-Unionized	-			
Unionized	6.00	5.00	5.00	5.00

Number of employees (Part-time equivalents (PTE's)):

	<u>2006 Board Approved</u>	<u>2006 Actual</u>	<u>2007 Bridge</u>	<u>2008 Test</u>
Executive				
Management				
Non-Unionized				
Unionized		1.00	1.00	1.00

Compensation (Total Salary and Wages (\$)):

	<u>2006 Board Approved</u>	<u>Average</u>	<u>2006 Actual</u>	<u>Average</u>	<u>2007 Bridge</u>	<u>Average</u>	<u>2008 Test</u>	<u>Average</u>
Executive								
Management								
Non-Unionized								
Unionized		46,820.67	446150.01	58944.60	459481.43	60564.36	474644.32	62562.99

Compensation (Total Benefits (\$)):

	<u>2006 Board Approved</u>	<u>Average</u>	<u>2006 Actual</u>	<u>Average</u>	<u>2007 Bridge</u>	<u>Average</u>	<u>2008 Test</u>	<u>Average</u>
Executive								
Management								
Non-Unionized								
Unionized		4,230.33	32228.04	4604.01	34803.23	4971.89	35847.33	5121.05



SIOUX-LOOKOUT HYDRO INC.

Compensation (Total Incentives (\$)):

		<u>2006 Board Approved</u>	<u>Average</u>		<u>2006 Actual</u>	<u>Average</u>		<u>2007 Bridge</u>	<u>Average</u>		<u>2008 Test</u>	<u>Average</u>
Executive												
Management												
Non-Unionized												
Unionized		n/a			n/a			n/a			n/a	

Total of Costs charged to O&M (\$):

		<u>2006 Board Approved</u>	<u>Average</u>		<u>2006 Actual</u>	<u>Average</u>		<u>2007 Bridge</u>	<u>Average</u>		<u>2008 Test</u>	<u>Average</u>
TOTAL		427,529.00			413,419.18			493,194.00			509,109.00	

Note: The 2006 Rate Handbook states the following:

“Where there are three, or fewer, full-time equivalents (FTEs) in any category, the applicant may aggregate this category with the category to which it is most closely related. This higher level of aggregation may be continued, if required, to ensure that no category contains three, or fewer, FTEs”

In compliance with the above, SLHI has aggregated information relating to the executive and management class into the unionized class.



File Number: EB-2007-0785

Exhibit: 4

Tab: 2

Schedule: 8

Page: 1

SIOUX-LOOKOUT HYDRO INC.

DEPRECIATION, AMORTIZATION AND DEPLETION

Details of SLHI's Depreciation, Amortization and Depletion are covered in Schedule 2, Tab 2 Gross Assets – Property, Plant and Equipment Accumulated Depreciation.

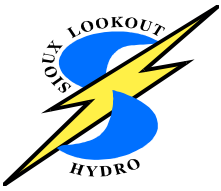

SIOUX-LOOKOUT HYDRO INC.

LOSS ADJUSTMENT FACTOR CALCULATION

2006 Board Approved LOSS FACTORS

Total Loss Factor – Secondary Metered Customer < 5,000 kW 1.0547

Total Loss Factor – Secondary Metered Customer > 5,000 kW 1.0145

Total Loss Factor – Primary Metered Customer < 5,000 kW 1.0442

Total Loss Factor – Primary Metered Customer > 5,000 kW 1.0045

Determination of Loss Adjustment Factor

		2002	2003	2004	2005	2006
A	"Wholesale" kWh (IESO)	95,762,817	98,114,759	98,070,741	98717832	96865995
B	Wholesale kWh for Large Use customer(s) (IESO)	0	0	0	0	0
C	Net "Wholesale" kWh (A)-(B)	95,762,817	98,114,759	98,070,741	98717832	96865995
D	Retail kWh (Distributor)	90,462,537	92,440,646	91,105,525	92835163	91252386
E	Retail kWh for Large Use Customer(s) (1% loss)	0	0	0	0	0
F	Net "Retail" kWh (D)-(E)	90,462,537	92,440,646	91,105,525	92,835,163	91,252,386
G	Loss Factor [(C)/(F)]	1.0600	1.0600	1.0760	1.0634	1.0615
H	Distribution Loss Adjustment Factor					1.06418

Total Utility Loss Adjustment Factor

	LAF
Supply Facility Loss Factor	1.0045
Distribution Loss Factors	
Secondary Metered Customer	
Total Loss Factor - Secondary Metered Customer < 5,000kW	1.0594
Total Loss Factor - Secondary Metered Customer > 5,000kW	1.0100
Primary Metered Customer	
Total Loss Factor - Primary Metered Customer < 5,000kW	1.0488
Total Loss Factor - Primary Metered Customer > 5,000kW	1.0000
Total Loss Factor	
Secondary Metered Customer	
Total Loss Factor - Secondary Metered Customer < 5,000kW	1.0642
Total Loss Factor - Secondary Metered Customer > 5,000kW	1.0145
Primary Metered Customer	
Total Loss Factor - Primary Metered Customer <	1.0535



File Number: EB-2007-0785

Exhibit: 4

Tab: 2

Schedule: 9

Page: 2

SIOUX-LOOKOUT HYDRO INC.

5,000kW	
Total Loss Factor - Primary Metered Customer > 5,000kW	1.0045
TOTAL LOSS FACTOR	

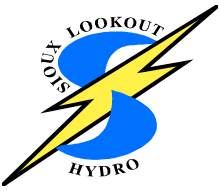

SIOUX-LOOKOUT HYDRO INC.

MATERIALITY ANALYSIS ON DISTRIBUTION LOSSES

As explained in schedule 10-5 of the 2006 EDR application, the reasons for the distribution loss exceeding 5% were that in early 2005, after a meter verification, SLHI discovered a metering error for a customer in the "GS over 50" class customer. This resulted in a change of approximately 500,000kWh/year.

In a second incident, upon completion of our statistics for 2004, it was discovered that a customer had suffered a significant reduction in usage. Following an investigation and a review from Measurement Canada it was discovered that a fuse had blown in the meter causing the consumption to be recorded at 33% lower than what it should have been. This error was corrected in March of 2005.

In a third event, a billing multiplier was incorrectly used causing the consumption to be recorded improperly. The difference in usage was approximately 100,000 kWhs. The same issue occurred for another customer in 2006. The consumption was recorded at 141,600 kWh but should have recorded as twice the consumption

As a result of these findings as well as performing transformer upgrades in several areas of the Municipality SLHI has seen a significant improvement in 2004, 2005 as well as 2006.

SLHI continues to work towards reducing the line loss through transformer upgrades and metering checks.



SIOUX-LOOKOUT HYDRO INC.

RETAIL TRANSMISSION ADJUSTMENT CALCULATIONS

MONTH	IESO	IESO	IESO	Network Billings	Connection Billings			
	Network	Line	Transformation					
	Service	Connection	Connection					
	Charge	Service	Service					
		Charge	Charge					
						Network	Connection	
Jan-06	\$53,335	\$15,939		\$46,620	\$40,325			
Feb-06	\$57,454	\$17,170		\$60,220	\$52,401	IESO Costs	\$775,335	\$228,656
Mar-06	\$46,090	\$13,774		\$51,606	\$44,930	Billing Revenues	\$843,080	\$725,786
Apr-06	\$41,245	\$12,274		\$47,411	\$41,377	Ratio	0.920	0.315
May-06	\$35,729	\$10,492		\$42,983	\$37,251			
Jun-06	\$28,252	\$8,296		\$35,783	\$30,978			
Jul-06	\$29,950	\$8,795		\$33,908	\$29,572			
Aug-06	\$28,690	\$8,425		\$33,170	\$28,792			
Sep-06	\$31,724	\$9,316		\$22,495	\$19,402			
Oct-06	\$38,669	\$11,355		\$53,686	\$39,622			
Nov-06	\$47,225	\$13,868		\$38,020	\$32,991			
Dec-06	\$48,392	\$14,210		\$45,337	\$39,524			
Jan-07	\$56,831	\$16,688		\$52,120	\$45,469			
Feb-07	\$54,855	\$16,108		\$55,061	\$47,899			
Mar-07	\$47,678	\$14,001		\$61,154	\$53,217			
Apr-07	\$38,685	\$11,360		\$50,809	\$44,338			
May-07	\$29,761	\$8,739		\$43,381	\$37,527			
Jun-07	\$29,975	\$8,802		\$33,224	\$29,035			
Jul-07	\$30,794	\$9,043		\$36,092	\$31,136			
Total	\$775,334	\$228,655		\$843,080	\$725,786			



SIOUX-LOOKOUT HYDRO INC.

TAX CALCULATIONS

Summary of Income Tax Calculation

INCOME TAX, LARGE CORPORATON TAX AND ONTARIO CAPITAL TAX TABLE	2006 Board Approved	2006 Actual	2007 Bridge	2008 Test
<u>Determination of Taxable Income</u>				
Regulatory Net Income (before tax)	265,678.00	161,910.00	101,176.00	262,199
Additions to Accounting Income:				
Interest and penalties on taxes	2,900.00			
Amortization of tangible assets	223,151.00	300,949.00	239,466.00	257,984
Loss on disposal of assets	400.00	825.00		
Non-deductible meals and entertainment expense	2,600.00	1,732.00		
Other Additions		9,761.00	181,771.00	170,500
Total Additions	229,051.00	313,267.00	421,237.00	428,484.00
Deductions from Accounting Income:				
Gain on disposal of assets per financial statements			(824.72)	-825
Capital cost allowance from Schedule 8	238,187.00	246,801.00	233,713.00	256,119
Cumulative eligible capital deduction from Schedule 10	12,866.00	11,965.00	11,127.48	10,349
Interest capitalized for accounting deducted for tax	6,548.00			
Capital Lease Payments	312.00			
Other Deductions		37,209.00	181,771.00	170,500
Total Deductions	257,913.00	295,975.00	425,786.76	436,143.00
Regulatory Taxable Income	236,816.00	179,202.00	96,626.24	254,540.00
Corporate Income Tax Rate			0.19	0.17
<u>Calculation of Utility Income Taxes</u>				
Income Taxes (Line 23)			17,991.81	43,271.80
Large Corporation Tax (Line 14, page 2)				
Total Taxes			22,108.39	52,134.70



SIOUX-LOOKOUT HYDRO INC.

CAPITAL COST ALLOWANCE

2006 Board Approved

Class	Class Description	UCC Opening Balance	Additions	Dispositions	UCC Before 1/2 Yr Adjustment	1/2 Year Rule {1/2 Additions Less Disposals}	Reduced UCC	Rate %	CCA	UCC Ending Balance
1	Distribution System - 1988 to 22-Feb-2005	5,164,496			5,164,496		5,164,496		206,580	4,957,916
2	Distribution System - pre 1988									
8	General Office/Stores Equip	25,450			25,450		25,450		5,090	20,360
10	Computer Hardware/ Vehicles	88,390			88,390		88,390		26,517	61,873
10.1	Certain Automobiles									
12	Computer Software									
13 1	Lease # 1									
13 2	Lease #2									
13 3	Lease # 3									
13 4	Lease # 4									
14	Franchise									
17	New Electrical Generating Equipment Acq'd after Feb 27/00 Other Than Bldgs									
43.1	Certain Energy-Efficient Electrical Generating Equipment									
45	Computers & Systems Software acq'd post Mar 22/04									
46	Data Network Infrastructure Equipment (acq'd post Mar 22/04)									
47	Distribution System - post 22-Feb-2005									
98	No CCA									
	TOTAL	5,278,336			5,278,336		5,278,336		238,187	5,040,149



SIOUX-LOOKOUT HYDRO INC.

Ex. Tab Schedule Contents of Schedule

5 – Deferral and Variance Accounts

1	1	Description of Deferral and variance accounts
	2	Calculation of Balances by Account
	3	2008 Rate Rider
	4	Method of Recovery



SIOUX-LOOKOUT HYDRO INC.

DESCRIPTION OF DEFERRAL AND VARIANCE ACCOUNTS

COMMODITY ACCOUNTS ARE CLASSIFIED AS FOLLOWS:

- 1588 Retail Settlement Variance Account – Power
Description: Capture the variance between the cost of power charged by Hydro One Networks Inc. (H.O.N.I.) to SLHI on Power bill and Power billed to SLHI customers.
- 1588 RSVA Power, Sub-account Global Adjustments
Description: Capture the variance between the Global Adjustments charged by Hydro One Networks Inc. (H.O.N.I.) to SLHI on Power bill and Global Adjustment billed to SLHI customers.

NON-COMMODITY ACCOUNTS ARE CLASSIFIED IN TWO CATEGORIES AS FOLLOWS:

Wholesale and Retail Market Variance Accounts

- 1518 Retail Cost Variance Account – Retail
- 1548 Retail Cost Variance Account – STR
- 1580 Retail Settlement Variance Account - Wholesale Market Service Charges
Description: Capture de variance between the Wholesale Market Service Charges billed by Hydro One Networks Inc. (H.O.N.I.) on Power bill and Wholesale Market Service Charges Charged to SLHI customers.
- 1582 Retail Settlement Variance Account - One-time Wholesale Market Service
Description: One-time Wholesale Market Service was billed by (H.O.N.I.) from January 1st, 2005 to May 1st, 2006 was charged to Embedded Utilities
- 1584 Retail Settlement Variance Account - Retail Transmission Network Charges

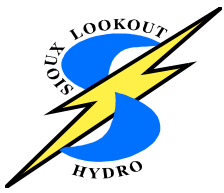

SIoux-LOOKOUT HYDRO INC.

Description: Capture de variance between the Retail Transmission Network Charges billed by Hydro One Networks Inc. (H.O.N.I.) on Power bill and Retail Transmission Network Charges Charged to SLHI customers.

Others Retail Transmission Network Charges billed by (H.O.N.I) from May 1st, 2002 to December 31st, 2004 was charged to Embedded Utilities Charges approved by OEB

Others Retail Transmission Network Charges billed by (H.O.N.I) from January 1st, 2005 to May1st, 2006 was charged to Embedded Utilities Charges approved by OEB

1586 Retail Settlement Variance Account - Retail Transmission Connection Charges

Description: Capture de variance between the Retail Transmission Connection Charges billed by Hydro One Networks Inc. (H.O.N.I.) on Power bill and Retail Transmission Connection Charges Charged to SLHI customers

Others Retail Transmission Connection Charges billed by (H.O.N.I) from May 1st, 2002 to December 31st, 2004 was charged to Embedded Utilities. Charges approved by OEB

Others Retail Transmission Connection Charges billed by (H.O.N.I) from January 1st, 2005 to May1st, 2006 was charged to Embedded Utilities. Charges approved by OEB

1588 Retail Settlement Variance Account - Power

Description: Refer to commodity accounts description

1588 Retail Settlement Variance Account - Power Sub-Account Global

Description: Refer to commodity accounts description.

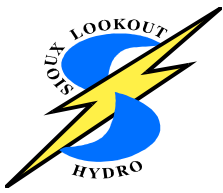

SIoux-LOOKOUT HYDRO INC.

Utility Deferral Accounts

1508 Other Regulatory Assets

Description: Other Regulatory Assets Charges billed by (H.O.N.I) from May 1st, 2002 to December 31st, 2004 was charged to Embedded Utilities.

Charges were approved by OEB

Other Regulatory Assets Charges billed by (H.O.N.I) from January 1st, 2005 to May1st, 2006 was charged to Embedded Utilities.

Charges approved by OEB Board.

1508 Other Regulatory Assets - Sub-account OEB Cost Assessments

Description: To capture the variance between OEB Cost Assessments amount approved in 1999 versus the actual OEB Cost Assessments charged.

1508 Other Regulatory Assets - Sub-account Pension Contributions

Description: To record the pension costs associated with the cash contributions paid to Ontario Municipal Employees Retirement Savings ("OMERS") for the period from January 1, 2005 to April 30, 2006.

1525 Miscellaneous Deferred Debits

Description: Others Miscellaneous Deferred Debits charges billed by (H.O.N.I) from May 1st, 2002 to December 31st, 2004 was charged to Embedded Utilities.

Charges approved by OEB

1550 LV Recovery Offset Variance

Description: Capture de variance between LV Charges billed by Hydro One Networks Inc. (H.O.N.I.) on Power bill and LV Charges Charged to SLHI customers.

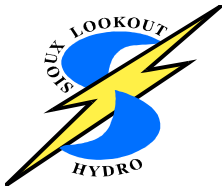

SIOUX-LOOKOUT HYDRO INC.

- 1555 Smart Meter Capital and Recovery Offset Variance
Description: To capture the amount billed to SLHI customers
- 1565 Smart Meter OM&A Variance
Description: To capture the amount spent by SLHI with respect to Smart Meter Operation and Maintenance
- 1562 Deferred Payments in Lieu of Taxes
Description: To record the amount resulting from the Board approved PILs methodology for determining the 2001 Deferral Account Allowance and the PILs proxy amount determined for 2002 and subsequent years.
- 1563 PILs contra account
Description: To record amounts relating to PILs and applicable only to a distributor using the third accounting method approved for recording entries in account 1562
- 1565 Conservation and Demand Management Expenditures and Recoveries Description: To capture amounts relating to the costs incurred for conservation and demand management activities and expenditures, and the revenue proxy amount equivalent to the distributor's (first generation) third tranche of MARR (market adjusted revenue requirement) or an amount otherwise approved by the Board.
- 1566 CDM Contra
Description: To record the offsetting entry for amounts recorded in account 1565, Conservation and Demand Management (CDM) Expenditures and Recoveries, for the reversal of entries to the accounts of original entries.
- 1572 Extraordinary Event Losses
Description: to record extraordinary event costs that meet the qualifying criteria established in the 2000 Electricity Distribution Rate Handbook.

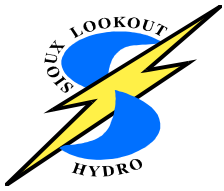

SIOUX-LOOKOUT HYDRO INC.

1574 Deferred Rate Impact Amounts

Description: To record amounts equal to rate impacts associated with market-based rate of return, transition costs, and extraordinary costs that the utility has determined to be excessive and has decided to defer to future periods

1592 PLS & Tax Variance

Description: To capture the Variance between the PILS & tax billed to SLHI customers and the amount of PILS payable

2425 Other Deferred Credits

Closed Accounts not classified are as follows:

1570 Qualifying Transition Costs (closed December 31, 2002)

Description: To capture all expenses for Transition Costs

1571 Pre-Market Opening Energy Variances (closed April 30, 2002)

Description: To capture the difference between the T.O.U and Non T.O.U short fall. Charges were approved by OEB

Note: SLHI follows and is in compliance with the OEB's Uniform System of Accounts for electricity distributors.

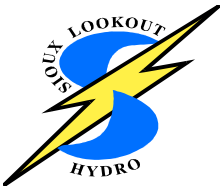

SIoux-LOOKOUT HYDRO INC.

Note 1:

The RSVA power account 1588 is designed to capture variances due to billing timing differences (i.e. electricity charged by IESO to LDCs vs. electricity billed by LDCs to their customers), price and quantity differences (i.e. arising from final vs. preliminary IESO settlement invoices), and line loss differences (i.e. actual vs. estimated line loss factors).

This account is not designed to capture any price differences between the regulated price plan (RPP) and spot prices applicable to RPP customers. This is the function of the Ontario Power Authority (OPA) RPP variance account which is trued-up in accordance with the terms established by the Board for the RPP.

Accordingly, since the RSVA power account is generic to all customers of an LDC, disposition of the account balance in rates is attributable to all its customers.

The 1588 RSVA power - Sub-account Global Adjustments is designed for the global adjustments applicable to non-RPP customers. Hence, the disposition of the account balance should be attributable to non-RPP customers.



SIOUX-LOOKOUT HYDRO INC.

				-		-		-	-		-	-		-	-		-
Deferred Payments in Lieu of Taxes	1562	(48,950)		(48,950)	YES	-		(48,950)	-		(48,950)	-		(48,950)	-		(48,950)
PILS Contra Account	1563	48,950		48,950	YES	-		48,950	-		48,950	-		48,950	-		48,950
CDM Expenditures and Recoveries	1565	29,286		29,286	YES	-		29,286	-		29,286	-		29,286	-		29,286
CDM Contra Account	1566	(29,286)		(29,286)	YES	-		(29,286)	-		(29,286)	-		(29,286)	-		(29,286)
Qualifying Transition Costs	1570	14,486		14,486	YES	-	(14,486)	(0)	-		(0)	-		(0)	-		(0)
Pre-Market Opening Energy Variances Total	1571	276,745		276,745	YES	-	(276,745)	0	-		0	-		0	-		0
Extra-Ordinary Event Losses	1572	12,859		12,859	YES	-	(6,540)	6,319	-		6,319	-		6,319	-		6,319
Deferred Rate Impact Amounts	1574			-	YES	-		-	-		-	-		-	-		-
RSVA - Wholesale Market Service Charge	1580	116,357	772	117,129	YES	-	(107,535)	9,594	-		9,594	-		9,594	-		9,594
RSVA - One-time Wholesale Market Service	1582	-		-	YES	-		-	-		-	-		-	-		-
RSVA - Retail Transmission Network Charge	1584	(39,676)	(226)	(39,903)	YES	-	14,583	(25,320)	-		(25,320)	-		(25,320)	-		(25,320)
RSVA - Retail Transmission Connection Charge	1586	(922,613)	(5,184)	(927,797)	YES	-	313,944	(613,853)	-		(613,853)	-		(613,853)	-		(613,853)
RSVA - Power	1588	520,389	2,961	523,350	YES	-	(449,634)	73,716	-		73,716	-		73,716	-		73,716
Deferred PILs Account	1592			-	YES	-		-	-		-	-		-	-		-
Other Deferred Credits	2425			-	YES	-		-	-		-	-		-	-		-
Sub-totals		513,540	255	513,794		-	(2,105,540)	(1,591,746)	-	520,848	(1,070,898)	-	1,026,768	(44,130)	-	-	(44,130)



SIOUX-LOOKOUT HYDRO INC.

Recovery of Regulatory Asset Balances (acct #1590)

Approved Balance						1,650,053												
Less Period Disposals							358,615			717,229			377,132				754,264	
Plus Period Interest							-			-			-				-	
Balance to (Refund) or Recover from 2006						1,650,053			1,291,438			574,209				197,076		(557,188)



SIOUX-LOOKOUT HYDRO INC.

Bridge Year (2007) Forecast

Customer Class	Metric	kW	kWhs	# Customers	EDR 2006 Approved Rates*	EDR 2007 Approved Rates**	Jan1/07 to Apr30/07 Disposal	May1/07 to Dec31/07 Disposal	Proportional Allocation
Residential	kWhs		33,377,072	2,297	0.0106	0.0106	117,932	235,865	33%
GS < 50 KW	kWhs		15,521,963	389	0.0104	0.0104	53,809	107,619	15%
GS > 50 Non TOU	kW	132,328	52,824,099	47	4.2041	4.2041	185,440	370,880	52%
GS > 50 TOU	kW						-	-	0%
Intermediate	kW						-	-	0%
Large Users	kW						-	-	0%
Small Scattered Load	kWhs		24,781	12	0.0104	0.0104	86	172	0%
Standby Power	kW						-	-	0%
Sentinel Lighting	kW						-	-	0%
Street Lighting	kW	1,477	478,103	533	2.7359	2.7359	1,347	2,694	0%
Additional Customer Class 1							-	-	0%
Additional Customer Class 2							-	-	0%
Additional Customer Class 3							-	-	0%
Additional Customer Class 4							-	-	0%
Totals		133,805	102,226,018	3,278			358,615	717,229	100%



SIOUX-LOOKOUT HYDRO INC.

Test Year (2008) Forecast

Customer Class	Metric	kW	kWhs	# Customers	Dx Revenue	# Customers w/Rebate Cheques	Additional Allocator 1	Additional Allocator 2	Additional Allocator 3	EDR 2007 Approved Rates	Jan1/08 to Apr30/08 Disposal	May 1/08 to Dec 31/08 Disposal						
Residential	kWhs		33,435,195	2,301	989,925					0.0106	118,138	236,275						
GS < 50 KW	kWhs		15,113,933	378	304,923					0.0104	52,395	104,790						
GS > 50 Non TOU	kW	146,406	58,443,684	52	484,290					4.2041	205,168	410,337						
GS > 50 TOU	kW									0.0000	-	-						
Intermediate	kW									0.0000	-	-						
Large Users	kW									0.0000	-	-						
Small Scattered Load	kWhs		24,781	12	3,408					0.0104	86	172						
Standby Power	kW									0.0000	-	-						
Sentinel Lighting	kW									0.0000	-	-						
Street Lighting	kW	1,475	477,656	533	11,121					2.7359	1,345	2,690						
Additional Customer Class 1											-	-						
Additional Customer Class 2											-	-						
Additional Customer Class 3											-	-						
Additional Customer Class 4											-	-						
Totals		147,881	107,495,249	3,276	1,793,667	-	-	-	-		377,132	754,264						



SIOUX-LOOKOUT HYDRO INC.

2008 RATE RIDER CALCUATION

Account Description	Account Number	Dec31/06 Balance	Apr 30/08 Balance	Allocation Basis	Residential	GS < 50 KW	GS > 50 Non TOU	GS > 50 TOU	Intermediate	Large Users	Small Scattered Load	Stand by Power	Sentinel Lighting	Street Lighting	Additional Customer Class 1	Additional Customer Class 2	Additional Customer Class 3	Additional Customer Class 4	Totals
Unrecovered Plant and Regulatory Study Costs	1505	-	-																-
Other Regulatory Assets	1508	80,098	84,982	KWh	26,433	11,949	46,203	-	-	-	20	-	-	378	-	-	-	-	84,982
Preliminary Survey and Investigation Charges	1510	-	-																-
Emission Allowance Inventory	1515	-	-																-
Emission Allowances Withheld	1516	-	-																-
Retail Cost Variance Account - Retail	1518	11,344	9,246	# Customers	6,494	1,067	147	-	-	-	34	-	-	1,504	-	-	-	-	9,246
Power Purchase Variance Account	1520	-	-																-
Misc. Deferred Debits - incl. Rebate Cheques	1525	14,098	0	# Customers w/Rebate Cheques	-	-	-	-	-	-	-	-	-	-	-	-	-	-	-
Deferred Losses from Disposition of Utility Plant	1530	-	-																-
Unamortized Loss on Reacquired Debt	1540	-	-																-
Development Charge Deposits/ Receivables	1545	-	-																-
Retail Cost Variance Account - STR	1548	-	-	# Customers	-	-	-	-	-	-	-	-	-	-	-	-	-	-	-
LV Variance Account	1550	435,959	384,051	KWh	119,455	53,998	208,803	-	-	-	89	-	-	1,707	-	-	-	-	384,051
Smart Meter Capital Variance Account	1555	-	-																-
Smart Meters OM&A Variance Account	1556	-	-																-
Deferred Development Costs	1560	-	-																-
Deferred Payments in Lieu of Taxes	1562	(48,950)	(51,945)	KWh	(16,157)	(7,304)	(28,242)	-	-	-	(12)	-	-	(231)	-	-	-	-	(51,945)

**SIOUX-LOOKOUT HYDRO INC.****Proposed Methodology**
Disposition of Variance and Deferral Accounts

1. An appropriate allocator (e.g. number of customer, kW's, kWh's) is assigned to each variance/deferral account ("Account"). The [actual/projected] Account balance as at [December 31, 2006/April 30, 2008]¹ is then apportioned to each customer class based on Test Year volume projections for the allocator. Example: if kWh's are assigned as the allocator for an account, and the Load Forecast for the Test Year indicates that 30% of kWh's will be consumed by the Residential customer class, then 30% of the Account balance is allocated to the Residential class.
2. [The projected residual balance in account 1590 as at April 30, 2008 is allocated to each customer class based on the recoveries projected in the Bridge Year for that class, from the date the current rate rider came into effect. Example: if current rate riders came into effect on May 1, 2007 and based on these rates, the Residential customer class is expected to account for 20% of all recoveries from May 1 to December 31, 2007, then 20% of the projected residual balance in account 1590 is allocated to the Residential class.]²
3. For each customer class, the sum of allocated balances over all Accounts selected for disposition is calculated. Example: if two Accounts are selected for disposition and the amounts allocated to the Residential customer class were \$50,000 for Account #1 and \$30,000 for Account #2, then the sum of allocated balances for the Residential class would be \$80,000.
4. For each customer class, the sum of allocated balances is divided by [two/three] to derive the annual recovery amount needed to clear the balances over [two/three] years. Example: if the sum of allocated balances for the Residential class is \$80,000, the annual recovery amount to clear the balances over [two/three] years would be [\$40,000/\$26,667].
5. For each customer class, the rate rider is calculated as the annual recovery amount divided by the Test Year forecast for the distribution rate volume metric, with the result rounded to the nearest one-hundredth of a cent,. Example: if the distribution rate volume metric for the Residential customer class is kWh's, and 100,000,000 kWh's are forecast for the Residential class in the Test Year, then the rate rider for the Residential class would be [\$0.0004 (=\$40,000 divided by 100,000,000) / \$0.0003 (=\$26,667 divided by 100,000,000)].

¹ [Square brackets including a slash (/)] indicate one of two approaches available in the DVAD model should be used in the description of the methodology.

² This paragraph applies only if the utility replied 'YES' for 'Clear residual 1590 balance as of April 30/08?' in the DVAD model.

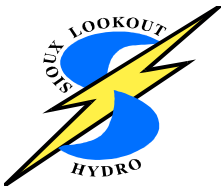

SIoux-LOOKOUT HYDRO INC.

<u>Ex.</u>	<u>Tab</u>	<u>Schedule</u>	<u>Contents of Schedule</u>
<u>6 – Cost of Capital and Rate of Return</u>			
	1	1	Overview
		2	Cost of Debt
		3	Return on Equity

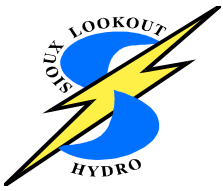
**SIoux-LOOKOUT HYDRO INC.****OVERVIEW**

The purpose of this evidence is to summarize the method and cost of financing the Applicant's capital requirements for the 2008 test years.

Capital Structure

The Applicant has a current a current capital structure of 50% debt, 50%, as approved by the Ontario Energy Board in RP-0000-0000, and a return on equity of 9.88%, consistent with the return specified in the Board's Decision in EB-0000-0000, dated Month, Day, Year. Sioux Lookout Hydro Inc. is requesting Board approval of a capital structure of 53% debt, 47% equity including an equity return of 8.68%.

The Applicant's weighted average cost of capital of 7.20% is summarized below. SLHI believes the requested capital structure and equity return will provide continued access to long-term debt at reasonable rates.

Description	Amount	Portion	Cost Rate	Weighted Avg.
Long Term Debt	3,191,975	49.33%	6.00%	2.96%
Shorts Term Debt	258,826	4.00%	4.77%	0.19%
Common Equity	3,019,856	46.67%	8.68%	4.05%
Total	6,470,658	100%		7.20%

Cost of Debt

Exhibit 6, Tab 1, Schedule 2 provides the detailed calculation of The Applicant's forecast long-term debt costs. Long-term debt cost information for the historical and bridge periods is also filed at Exhibit, Tab, Schedule.

Return on Equity

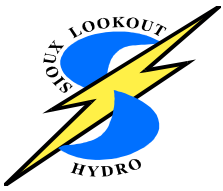

File Number: EB-2007-0785

Exhibit: 6

Tab: 1

Schedule: 1

Page: 3

SIoux-LOOKOUT HYDRO INC.

The Applicant is requesting an equity return of 8.68% for 2008 test years. The methodology of calculating the ROE is based on the "*Report of the Board on Cost of Capital and 2nd Generation Incentive Regulation for Ontario's Electricity Distributors*" issued by the Ontario Energy Board December 20, 2006. Exhibit, Tab, Schedule provides the excerpt from the report.



SIOUX-LOOKOUT HYDRO INC.

COST OF DEBT

	Issue Date	Amt OS	Rate	Term Date	Year	Yr Days	AvgBal	Cost
Demand Installment Loan	10-Apr-02	1,901,667	4.00%	04-Jul-07	2004	366	1,901,667	76,067
Demand Installment Loan	10-Apr-02	1,761,667	4.42%	04-Jul-07	2005	365	1,761,667	77,866
Demand Installment Loan	10-Apr-02	1,621,667	5.81%	04-Jul-07	2006	365	1,621,667	94,219
Demand Installment Loan	10-Apr-02	1,563,334	6.00%	04-Jul-07	2007	185	792,375	47,542
Demand Installment Loan	04-Jul-07	2,789,823	6.00%	01-Jun-22	2007	181	1,383,446	83,007
Demand Installment Loan	04-Jul-07	2,712,323	6.00%	01-Jun-22	2008	366	2,712,323	162,739

Debt Instrument	2004	2005	2006	2007	2008
Demand Installement Loan	1,901,667	1,761,667	1,621,667	2,175,821	2,712,323
Grand Total	1,901,667	1,761,667	1,621,667	2,175,821	2,712,323

Debt Service Costs	2004	2005	2006	2007	2008
Demand Installement Loan	76,067	77,866	94,219	130,549	162,739
Grand Total	76,067	77,866	94,219	130,549	162,739

Debt Rate	2004	2005	2006	2007	2008
Debt Service Costs	76,067	77,866	94,219	130,549	162,739
Average Debt Outstanding	1,901,667	1,761,667	1,621,667	2,175,821	2,712,323
Effective Debt Rate	4.00%	4.42%	5.81%	6.00%	6.00%

**SIOUX-LOOKOUT HYDRO INC.****RETURN ON EQUITY**

The calculations used to determine the return on equity and the debt are taken from the "Report to the Board on Cost of Capital and 2nd Generation Incentive Regulation for Ontario's Electricity Distributors" issued December 20, 2006.

Excerpt from the Report of the Board on Cost of Capital and 2nd Generation Incentive Regulation for Ontario's Electricity Distributors Appendix A and Appendix B

Method to Update the Deemed Long-term Debt Rate

The Board will use the Long Canada Bond Forecast plus an average spread with "A/BBB" rated corporate bond yields to determine the updated deemed debt rate.

The following approach is consistent with the ROE method. As per the approach adopted in the 2006 EDRH, the ROE and the long-term debt rates are based on the same risk-free rate forecast. Therefore, they differ only through the risk premiums that reflect their distinct natures and for which lenders/investors seek commensurate returns. This approach simplifies the calculations and aims to make it easier to understand the numbers. Specifically, the Long Canada Bond Forecast ($LCBF_t$) used will be the same as that used for updating the ROE. The average spread between "A/BBB" rated corporate bond yields and 30-year (long) Government of Canada Bond yields will be calculated as the average spread over the weeks of the month corresponding to the Consensus Forecasts.

The deemed Long-Term Debt Rate ($LTDR_t$) will be calculated as follows:

$$LTDR_t = LCBF_t + \frac{\sum_w (CorpBonds_{w,t} - {}_{30}CB_{w,t})}{n}$$

Where:

- **$CorpBonds_{w,t}$** is the average long-term corporate bond yield from Scotia Capital Inc. for week w of period t [Series V121761];
- **${}_{30}CB_{w,t}$** is the 30-year (long) Government of Canada bond yield for week w of period t [Series V121791]; and
- **n** is the number of weeks in the month for which data are reported.

**SIOUX-LOOKOUT HYDRO INC.****Method to Update ROE - ROE Update for any Period**

Using March 1999 as the starting calculation and substituting for the initial ROE and Long Canada Bond Forecast approved by the Board in the Decision RP-1998-0001 the following is the adjustment formula for calculating the ROE at time t :

$$ROE_t = 9.35\% + 0.75 \times (LCBF_t - 5.50\%)$$

The ROE must be set in advance of the approved rates. The final ROE will be factored into rates using the Long Canada Bond Forecast based on *Consensus Forecasts* (as detailed below) and Bank of Canada data three months in advance of the effective date for the rate change. Therefore, for May 1 rate changes, the ROE will be based on January data – effectively *Consensus Forecasts* published during that month and Bank of Canada data for all business days during the month of January. The necessary data is available within the first or second business days after the end of the month and thus poses no delay for determining rates.

Long Canada Bond Forecast for any Period

For any period t the Long Canada Bond Forecast $LCBF_t$ can be expressed as:

$$LCBF_t = \left[\frac{{}_{10}CBF_{3,t} + {}_{10}CBF_{12,t}}{2} \right] + \frac{\sum_i ({}_{30}CB_{i,t} - {}_{10}CB_{i,t})}{I_t}$$

Where:

${}_{10}CB_{3,t}$ is the 3-month forecast of the 10-year Government of Canada bond yield as published in *Consensus Forecasts* at time t ;

${}_{10}CB_{12,t}$ is the 12-month forecast of the 10-year Government of Canada bond yield as published in *Consensus Forecasts* at time t ;

${}_{30}CB_{i,t}$ is the actual rate for the 30-year Government of Canada bond yield at the close of day i (as published by the Bank of Canada) [Series V39056] during the month (this is the previous month data, the same as used for updating the ROE for natural gas distribution) corresponding to time t ;

${}_{10}CB_{i,t}$ is the actual rate for the 10-year Government of Canada bond yield at the close of day i (as published by the Bank of Canada) [Series V39055] during the month corresponding to time t ; and

I_t is the number of business days for which published 10- and 30- Government of Canada bond yields are published during the month corresponding to time t .

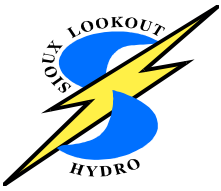

SIOUX LOOKOUT HYDRO INC.

Ex. Tab Schedule Contents of Schedule

7 - Calculation of Revenue Deficiency or Surplus

1	1	Overview of Calculation of Revenue Deficiency or Surplus
	2	Determination of Net Utility Income



SIOUX LOOKOUT HYDRO INC.

OVERVIEW OF CALCULATION OF REVENUE DEFICIENCY OR SURPLUS

This exhibit presents an overview of the revenue deficiency or surplus calculations process for the 2008 test year

The increase in SLHI's distribution expenses including depreciation expense in the 2008 Test Year of \$1,403,511 is a result of normal operating expenses plus inflation plus additional amortization related to the Capital program at SLHI

The change in SLHI's return on capital in the 2008 Test Year of \$466,064 indicated that the utility was not earning its regulated return based on 2006 EDR which is based on 2004 actual.

The change in SLHI's PILs in the 2008 Test Year of \$52,135 relative to the estimated amount to be collected based on decreased tax rates and increased revenue

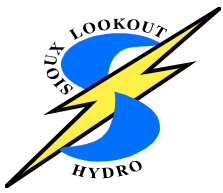

SIOUX LOOKOUT HYDRO INC.

DETERMINATION OF NET UTILITY INCOME

	2008 Test Existing Rates	2008 Test Proposed Rates
Revenue		
Suff/ Def From Below.		215,122
Distribution Revenue	1,532,447	1,532,447
Other Operating Revenue (Net)	174,140	174,140
Total Revenue	1,706,587	1,921,709
Distribution Costs		
Operation, Maintenance, and Administration	1,145,527	1,145,527
Depreciation & Amortization	257,984	257,984
Capital Tax		0
Interest- Deemed Interest	203,865	203,865
Total Costs and Expenses	1,607,376	1,607,376
Utility Income Before Income Taxes	99,211	314,333
Net Adjustments per 2008 Pils	-7,658	-7,658
	91,553	306,675
Income Tax (Tax Rate 17%)	15,564	52,135
Utility Income	83,647	262,198
Rate Base	6,470,658	6,470,658
Equity	0.4667	0.4667
Equity Component Rate Base	3,019,640	3,019,640
Income / Equity Rate Base %	2.77%	8.68%
Target Return -Equity on Rate Base	8.68%	8.68%
Return- Equity on Rate Base	262,198	262,198
Revenue Deficiency	178,551	



File Number: EB-2007-0785

Exhibit: 7

Tab: 1

Schedule: 2

Page: 1

SIOUX LOOKOUT HYDRO INC.

Revenue Deficiency (Gross-up)

215,122

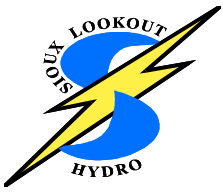

File Number: EB-2007-0785

Exhibit: 8

Tab: 1

Schedule: 1

Page: 1

SIOUX LOOKOUT HYDRO INC.

<u>Ex.</u>	<u>Tab</u>	<u>Schedule</u>	<u>Contents of Schedule</u>
<u>8 – Cost Allocation</u>			
	1	1	Cost Allocation Overview
		2	Summary of Results and Proposed Changes



SIOUX LOOKOUT HYDRO INC.

COST ALLOCATION OVERVIEW

Introduction:

On September 29, 2006 the OEB issued its directions on Cost Allocation Methodology for Electricity Distributors (“the Directions”). On November 15, 2006, the Board issued the Cost Allocation Information Filing Guidelines for Electricity Distributors (“the Guidelines”), the Cost Allocation Model (“the Model”) and User Instructions (the “Instructions”) for the Model. SLHI prepared a cost allocation information filing consistent with SLHI understanding of the Directions, the Guidelines, the Model and the Instructions. SLHI submitted this filing to the OEB on February 28, 2007.

One of the main objectives of the filing was the provision of information that will indicate any apparent cross-subsidization among rate classifications within a distributor.

Background:

In the mid 1980’s, Ontario Hydro, at the time the regulator of the distribution sector, completed the most recent cost allocation study that reflected the distribution function, but this was an integrated cost allocation study. The integrated study reviewed the full costs of providing electricity to customers which included energy, transmission and distribution. Distribution represented only approximately 15% of the total costs reviewed. The results of this study assisted Ontario Hydro in developing the Standard Application of Rates that were used by Municipal Electric Utilities to develop the bundled rates they charged customers until 2000.

Under the *Energy Competition Act, 1998*, the former Ontario Hydro was restructured into separate transmission/distribution (Hydro One) and generation (Ontario Power Generation) companies (among others). This was in part to facilitate the establishment of competitive markets for the electricity as a commodity. In furtherance of that objective, the rates charged by distributors were “unbundled” from transmission and commodity portions of the customer’s bill. The unbundling also facilitated the addition of commercial returns on equity, debt rates and Payments in Lieu of Taxes (“PILs”) to the distribution rates, in keeping with government



SIOUX LOOKOUT HYDRO INC.

policy. The unbundling of distribution from generation and transmission was completed in the 2000/2001 timeframe using the OEB's 2000 Electricity Distribution Rate Handbook and the Rate Unbundling and Design Model (the "RUD" model). The Rate Handbook and RUD model provided a method to unbundle distribution rates from the other rates by rate classification but they did not determine whether the unbundled rates fully collected the cost of providing distribution service to each rate classification. The cost allocation informational filing process in 2006 represented the first time a cost allocation study has been conducted in Ontario that focuses completely on distribution costs to determine whether or not the distribution rates are collecting the cost of providing distribution service to the corresponding rate classifications

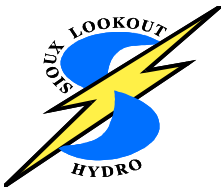

SIOUX LOOKOUT HYDRO INC.

SUMMARY OF RESULTS AND PROPOSED CHANGES

Revenue to Cost Ratios

The cost/financial data used in the Model was consistent with SLHI's cost data that supported its 2006 OEB-approved distribution rates. Consistent with the Guidelines, SLHI's assets were broken out into primary and secondary distribution functions. The breakout of assets, capital contributions, depreciation, accumulated depreciation, customer data and load data by primary, line transformer and secondary categories were developed from the best data available from SLHI's engineering records and customer and financial information systems.

The results of a cost allocation study are typically presented in the form of revenue to cost ratios. The ratio is shown by rate classification and is the percentage of distribution revenue collected by rate classification compared to the costs allocated to the classification. The percentage shows the rate classifications that are being subsidized and those that are over-contributing. A percentage of less than 100% means the rate classification is under-contributing and is being subsidized by other classes. A percentage of greater than 100% indicates the rate classification is over-contributing the cost assigned to the classification and is subsidizing other classes.

The following table outlines the revenue to cost ratios from the cost allocation informational filing submitted by SLHI. In addition, the dollar amount that each rate classification is being subsidized or over-contributing is provided.

**SIOUX LOOKOUT HYDRO INC.****Table 1****Revenue to Cost Ratios as Filed in Sioux-Lookout Hydro Inc.
2007 Cost Allocation Informational Filing**

Rate Classification	Revenue to Cost Ratio	(\$Being Subsidized)/ \$Over Contributing
Residential	97.16%	(\$27,028)
General Service <50 kW	106.44%	\$20,527
General Service > 50 kW	150.58%	\$114,656
Street Lights	10.41%	(\$108,167)
USL	100.45%	\$14
Total	100.0%	\$2

Since the unbundled distribution rates had never been based on costs it was expected the Residential class would be the rate class being subsidized based on the method used to previously design the bundled rates for customers of a Municipal Electric Utility ("MEU"). Prior to the passing of Bill 35 by the Ontario Government on October 30, 1998, a MEU was regulated by Ontario Hydro. In order to assist a MEU with setting the retail rates for their customers, Ontario Hydro provided the MEU Rate Setting Guidelines. These guidelines provided guidance to a MEU on how to develop the bundled retail rates for their customers. However, the guidelines allowed the utility to charge a kWh rate for General Service customers that was up to 10% higher than the Residential customers. A review of SLHI rates prior to unbundling indicated General Service customers paid a kWh rate almost 8% higher than Residential customers.

In the unbundling process, the unbundled distribution rates were determined by subtracting an estimate of the cost of power (i.e. generation and transmission) from the bundled rates. Assuming the cost of power is the same for all customers the unbundled distribution rates for General Service customers would be higher than Residential rates because the bundled

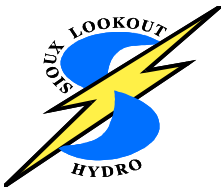

SIoux LOOKOUT HYDRO INC.

General Service rates were higher. This means the above results for Residential and General Service rate classifications appear to be reasonable.

However, in the General Service > 50 kW rate classification the 2004 transformer ownership allowance of around \$30,437 were not applied to the revenue which means the revenues in the Model could be overstated for this rate classification. This in turn would reduce the 'over contributing' amount of \$114,656 to around \$84,219 and it was estimated the revenue to cost ratio would be reduced from 150.58% to about 137%.

With regards to streetlights, it was assumed in the cost allocation study that a streetlight was equivalent to a customer. This appeared to be reasonable because in the case of other rate classifications each connection is essentially a customer. This meant the customer costs allocated to streetlights were based on 537 connections which is the biggest driver that is causing the results for this classification. SLHI is in the opinion that although the Street Lighting class continues to be insufficient to cover the costs of servicing this class, SLHI understands that this is not only an issue for Sioux Lookout Hydro Inc but an issue for all distributors in Ontario. SLHI therefore proposes to maintain the current ratio for the Streetlight class until OEB reviews this issue on a provincial basis.

Regarding the USL results, costs were allocated to this rate classification based on the number of connections and not the number of customers. The revenue to cost ratio is 100.45% for USL. This appeared then, and still now, to be very reasonable.

Monthly Fixed Charge Comparison

The Cost Allocation Model produced customer unit costs per month for each rate classification. To assist with reviewing the range of current fixed monthly service charges, the Model generated three scenarios of reasonable cost-based customer unit costs for each rate

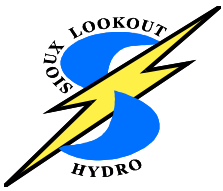

SIoux LOOKOUT HYDRO INC.

classification. These unit costs were determined by the Model and compared to the current approved monthly service charge.

Scenario 1: Avoided Costs

With a strict “avoided cost” approach, only meter related costs, billing and collection costs are included. This approach has the advantage of focusing on the immediate costs of an additional customer. But no administration and general overhead costs are applied.

Scenario 2: Directly Related Customer Costs

The directly related customer costs are those costs included in the avoided cost version but an allocation of administration and general overhead costs is included.

Scenario 3: Minimum System Approach

The minimum system approach assumes that a minimum-size distribution system can be built to serve the minimum load requirements of the customer. For the purposes of this filing the minimum load requirement is assumed to be 400 watts per customer. The minimum system method involves determining the minimum size pole, conductor, cable, transformer, and service that is currently installed by the distributor. Once determined for each plant account, the minimum size distribution system is classified as customer-related costs and then used to define the monthly unit customer cost.

There were various approaches to defining the minimum system. Moreover, judgment is required to address various implementation details with this methodology. The OEB cost allocation project did not seek to develop a common minimum system methodology for use by the Ontario electricity distribution sector. Instead, the results of numerous past Ontario minimum system studies were examined and approved for use in the Model.

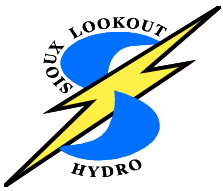

SIOUX LOOKOUT HYDRO INC.

The minimum system results were applied to the following accounts:

- Line Transformers (Account 1850)
- “Distribution” which includes poles and conductors, and is defined as Accounts 1830 - 1845
- Related O&M accounts.

The density of the distributor (i.e. customers/route kilometer of line) was found to be the major factor that determines the percentage of the above costs which are included in the customer costs. The density of SLHI is 13 customers/km. Consequently SLHI was classified as a low density distributor. As a result, 60% of SLHI’s distribution costs (i.e. lines, poles and line transformers) were defined to be customer related cost.

The monthly customer unit cost under the minimum system approach included the directly related customer costs plus 40% of distribution costs with any administration and general overhead associated with the distribution costs. In SLHI’s view, of the three scenarios, the Minimum System Approach appeared to be the most reasonable approach to determine the customer unit costs per month as it better reflected the fixed costs of providing service to a customer.

The following outlines the monthly fixed cost comparison.

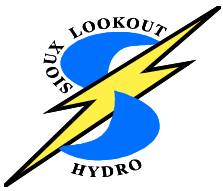
**SIOUX LOOKOUT HYDRO INC.****SUMMARY OF MONTHLY SERVICE CHARGE**

Rate Classification	Approved Fixed Charge	Minimum System Fixed Charge	Directly Related Fixed Charge	Avoided Cost Fixed Charge	2008 Proposed Rates
Residential	\$20.12	\$24.32	\$7.55	\$5.35	\$23.15
General Service <50 kW	\$35.73	\$35.21	\$21.05	\$15.30	\$41.32
General Service >50 kW	\$411.24	\$63.43	\$51.70	\$38.74	\$473.17
Street Lights	\$.86	\$18.73	\$.01	\$.01	\$0.99
USL	\$17.74	\$20.32	\$2.12	\$1.52	\$20.50

Assuming the Minimum System Fixed Charge was deemed the most reasonable scenario, the above results suggested the monthly fixed charge for SLHI Residential customers should increase and the charge for General Service < 50 kw should decrease slightly. The results also suggested the monthly fixed charge for SLHI customers that were greater than 50 kW should be reduced significantly. These results were somewhat expected as the main cost drivers that produce a difference in the monthly unit customer cost between rate classifications was the difference in cost for meters, meter reading, billing and collecting. In reviewing the Model it appeared the Miscellaneous Service Revenue allocated to each rate classification was also applied to the calculation of the fixed charges and in the case of General Service > 50 Kw the amount allocated to this rate classification appeared to be unreasonable.

It is still SLHI's view that before new monthly fixed charges are implemented, the OEB should revisit the calculation of these fixed charges to ensure the outcomes are reasonable and that Miscellaneous Service Revenues are reflected properly in the calculations.

Transformer Ownership Allowance

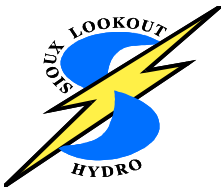

SIOUX LOOKOUT HYDRO INC.

Currently, SLHI provides a transformer ownership allowance to those customers that own their transformation facilities. SLHI's present transformer ownership allowance is \$0.60 per kW and this same charge is applied consistently across the province. The amount of the allowance has not been reviewed on a generic basis in recent years. The filings will be used by the OEB to review this allowance from a cost based perspective.

The present allowance is intended to reflect the costs to a distributor of providing step down transformation facilities to the customer's utilization voltage level. Since it is assumed that the distributor provides electricity at utilization voltage, the cost of this transformation is captured in and recovered through the distribution rates. Therefore, when a customer provides the step down transformation from primary to secondary, it should receive a credit of these costs already included in the distribution rates.

In SLHI's case, the Model is suggesting the transformer ownership allowance from a cost based perspective should be \$0.3731 per kW. In SLHI's view, this amount appears to be reasonable but suggest the OEB review this issue on a provincial basis before the current the transformer ownership allowance is adjusted.



SIOUX LOOKOUT HYDRO INC.

<u>Ex.</u>	<u>Tab</u>	<u>Schedule</u>	<u>Contents of Schedule</u>
<u>9 - Rate Design</u>			
	1	1	Rate Design Overview
		2	Rate Mitigation
		3	Existing Rate Classes
		4	Existing Rate Schedule
		5	Proposed Rate Classes if different than existing
		6	Proposed Rate Schedule
		7	Determination of Service Revenue Requirement
		8	Reconciliation of Rate Class Revenue to total Revenue Requirement
		9	Rate Impacts
		10	Proposed Changes to Terms and Conditions of Service

SIoux LOOKOUT HYDRO INC.

RATE DESIGN OVERVIEW

This exhibit documents the calculation of SLHI's proposed distribution rates by rate class for the 2008 test year, based on rate design as proposed in this Exhibit.

SLHI has determined its total 2008 service revenue requirement to be \$1,921,709. The total revenue offsets is in the amount of \$174,140 reduces SLHI's total service revenue requirement to a base revenue requirement to \$1,747,569, which is used to determine the proposed distribution rates. The base revenue requirement is derived from SLHI's 2008 capital and operating forecasts, weather normalized usage, forecasted customer counts, and SLHI's regulated return on rate base. The revenue requirement is summarized in the table below

Calculation of Base Revenue Requirement

OM&A Expenses	1,145,527.02
Amortization Expenses	<u>257,983.66</u>
Total Distribution Expenses	1,403,510.67
Regulated Return On Capital	466,063.52
PILs (with gross-up)	<u>52,134.81</u>
Service Revenue Requirement	1,921,709.01
Less: Revenue Offsets	<u>-174,140</u>
Base Revenue Requirement	1,747,569

Determination of Monthly Fixed Charges:

SLHI's current OEB-approved monthly fixed charges based on its 2007 IRM application, and before the smart meter adder, by customer class are summarized in the table below.

SIOUX LOOKOUT HYDRO INC.

Current Monthly Fixed Charges

Rate Class	Current Monthly Fixed Charge
Residential	\$20.30
GS <50 kW	\$36.05
GS>50 kW	\$414.94
Street Light	\$0.87
Unmetered Scattered Load	\$17.90

SLHI has calculated the proportion of fixed distribution as a percent of total distribution revenue derived by customer class based on existing rates established through the 2007 IRM model. Table below illustrates the allocation of distribution revenue between fixed and variable. SLHI proposes to maintain this consistent fixed / variable distribution revenue split in its 2008 application.

SIOUX LOOKOUT HYDRO INC.**Allocation Between Fixed and Variable % Distribution Revenues at Existing Rates**

2008 Test Year	Fixed	Variable	Grand Total	Fixed	Variable	Grand Total
Residential	560,524	290,886	851,410	65.83%	34.17%	55.56%
Unmetered Scattered Load	2,578	169	2,746	93.86%	6.14%	0.18%
GS <50	172,607	108,399	281,006	61.42%	38.58%	18.34%
GS>50-Regular	214,109	174,227	388,336	55.14%	44.86%	25.34%
Street Light	5,559	3,390	8,949	62.12%	37.88%	0.58%
Grand Total	955,377	577,070	1,532,447	62.34%	37.66%	100.00%

SLHI submits that it is appropriate for 2008 to maintain the same fixed/variable proportions as calculated in the 2007 IRM filing. This matter is discussed further below.

In September 2006 the OEB completed its Cost Allocation Review and issued the Board Directions on Cost Allocation Methodology For Electricity Distributors, RP-2005-0317. The results of this Board report stem from at least three years of discussions and work groups which included OEB staff, electricity distributors, intervenors and experts at various stages of the review process. Subsequently, in November of 2006, the OEB issued the Cost Allocation Informational Filing Guidelines for Electricity Distributors (“the Guidelines”) and the cost allocation Model. The Guidelines and Model provided LDCs the framework to complete their cost allocation studies which were filed in early 2007.

In its follow-up to the review of the cost allocation filings, the OEB issued a “Board Staff Discussion Paper On the Implications Arising from a Review of the Electricity Distributors’ Cost Allocation Filings” (EB-2007-0667), in which OEB staff have requested comments on proposed ranges for revenue to cost ratios and well as ranges for the fixed distribution charges.

Board staff makes the suggestion in Section 3.5 of the Discussion Paper (Implications Arising from the Determination of class Specific Revenue to Cost Ratios) that “no distributor’s revenue to cost ratios should be outside the ranges, without significant justification...” and further that “Any distributor with a class ratio that falls outside the suggested ranges should re-align its distribution rates so that all classes fall with the respective ranges.” OEB staff

SIOUX LOOKOUT HYDRO INC.

further recognize throughout this section that “for some customer classes, there could be higher than average rate adjustments.” and that “Any significant adjustments to rates must consider the range of factors associated with rate changes which may not allow for immediate full adjustments.”

In Section 4 of the Discussion Paper, OEB staff provide an analysis of fixed distribution charges and suggest an upper and lower range based on the minimum system concept. This concept has been a long-standing methodology for cost allocation studies, however OEB staff are proposing that each distributor set fixed rates within these ranges “at the time of its next rebasing rate application.” SLHI submits that OEB staff comments in this section of the Staff Discussion Paper are contradictory to other Reports, Decisions and OEB initiatives, which are currently outstanding and in fact support the notion of an overall review of fundamental distribution rate design as discussed below.

SLHI further submits that the Staff suggestion is in fact a proposed approach to rate design, and SLHI suggest that this is premature at this time and in addition, this study should not be used in isolation of other factors to make determinations on rate design. Instead, the issue of the appropriate split between fixed and variable distribution charges should be moved to the OEB’s proceeding EB-2007-0031– Rate Design for Electricity Distributors – in which the OEB is considering rate design issues.

The March 30, 2007 OEB Staff Discussion Paper in EB-2007-0031 – “Rate Design for Electricity Distributors: Overview and Scoping” – was issued “primarily to solicit input from interested parties that will enable Board staff to better understand which areas, if any, might be a priority for distributors and consumers” in key rate design principles.

This Discussion Paper clearly invites stakeholder input on key rate design principles, which will include the fixed and variable distribution rate design. SLHI agrees with certain comments that were made such as

The rates should be set such that the risk to the recovery of the LDC’s revenue requirement is minimized;

SIoux LOOKOUT HYDRO INC.

- The rates should not be overly complicated for either the customer to understand or for the LDC to implement; and
- The rates charged a specific customer class should reflect as closely as possible the actual costs incurred by that LDC to provide distribution service to that customer class – and nothing more.

As the fundamental rate design still needs to go into the consultation process SLHI submits that any changes beyond those being proposed to the existing fixed variable distribution rate and revenue proportions are beyond the scope of this 2008 rate application process and as such should not be addressed without a full rate design process.

Table 11 below provides SLHI calculations of its proposed monthly fixed distribution charges for the 2008 Test Year.

**Table 11
 Proposed Fixed Distribution Charge**

Customer Class	Total Net Rev. Requirement	Fixed charges as percent of total for customer class	2008 Test Year Customers	Proposed Fixed Distribution Charge
Residential	970,949	65.83%	2301	\$23.15
GS <50 kW	320,504	93.86%	399	\$41.32
GS>50 kW	442,834	61.42%	43	\$473.17
Street Light	10,136	55.14%	533	\$0.99
Unmetered Scattered Load	3,146	62.12%	12	\$2.50
Total	1,747,569			

Proposed Volumetric Charges:

The variable distribution charge is calculated by dividing the variable distribution revenue requirement by the appropriate 2008 Test Year usage, kWh or kW, as the class charge determinant and applying adjustments relating to Transformer Allowance for the General Service > 50 kW customer class and Low Voltage Charges.

SIOUX LOOKOUT HYDRO INC.

Table below summarizes both the proposed variable distribution revenue and the proposed variable distribution charge.

Variable Distribution Charge Calculation

Customer Class	Before Adjustment			Transformer Allowance Impact			Low Voltage Charges		Adjusted Rates		Fixed Charge
	Usage Rate	per	Total \$	Load	Rate	Total \$	Load	Rate	Usage	per	
Residential	0.0099	kWh	0.00	33435195	0.0000	122,816.98	33435195	0.0037	0.0136	kWh	23.15
GS <50	0.0078	kWh	0.00	15941009	0.0000	53,083.35	15941009	0.0033	0.0111	kWh	41.12
GS>50-Regular	1.6411	kW	36,926.40	121066	-0.3050	162,506.59	121066	1.3423	2.6784	kW	473.17
Street Light	2.5824	kW	0.00	1475	0.0000	1,510.56	1475	1.0239	3.6063	kW	0.99
ULS	0.0078	kWh	0.00	24781	0.0000	82.52	24781	0.0033	0.0111	kWh	20.5
TOTAL			36,926.40			340,000.00					

Proposed Adjustment to Transformer Allowance:

The amount of Transformer Allowance expected to be provided to those GS > 50 kW customers that own their transformers has been included in the GS > 50 kW volumetric charge. This means the GS > 50 kW volumetric charge has been increased by the amount of the Transformer Allowance. Once the Transformer Allowance is applied to this charge the resulting revenue will recover the full base revenue requirement for the GS > 50 kW rate class.

Currently, SLHI provides a Transformer Allowance to those customers that own their transformation facilities. SLHI current approved transformer ownership allowance is \$0.60 per kW. The Transformer Allowance is intended to reflect the costs to a distributor of providing step down transformation facilities to the customer's utilization voltage level. Since the distributor provides electricity at utilization voltage, the cost of this transformation is captured in and recovered through the distribution rates. Therefore, when a customer provides its own step down transformation from primary to secondary, it should receive a credit of these costs already included in the distribution rates. SLHI has calculated the proposed Transformer Allowance for the 2008 rate application as \$0.305

SIOUX LOOKOUT HYDRO INC.**Proposed Distribution Rates:**

The following table sets out SLHI proposed 2008 electricity distribution rates based on the foregoing calculations, including adjustments for the recovery of LV costs:

**Table 14
Proposed 2008 Electricity Distribution Rates**

Customer Class	Customer	Connection	kWh	kW
Residential	23.15		0.0136	
GS <50 kW	41.12		0.0111	
GS>50 kW	473.17			2.6784
Street Light		0.99		3.6063
Unmetered Scattered Load		20.50	0.0111	
Transformer Allowance				0.305

SIoux LOOKOUT HYDRO INC.

RATE MITIGATION

Sioux-Lookout Hydro Inc. considers the proposed rate adjustment not to be of such impact to the customer that it requires rate mitigation.

SIOUX LOOKOUT HYDRO INC.

EXISTING RATE CLASSES

Residential

This classification applies to an account taking electricity at 750 volts or less where the electricity is used exclusively in a separate metered living accommodation. Customers shall be residing in single-dwelling units that consist of a detached house or one unit of a semi-detached, duplex, triplex or quadruplex house, with a residential zoning. Separately metered dwellings within a town house complex or apartment building also qualify as residential customers. All customers are single-phase.

General Service Less Than 50kW

This classification applies to a non residential account taking electricity at 750 volts or less whose average monthly maximum demand is less than, or is forecast to be less than, 50 kW.

General Service 50 to 999kW

This classification applies to a non residential account whose average monthly maximum demand used for billing purposes is equal to or greater than, or is forecast to be equal to or greater than, 50 kW but less than 5,000 kW. Note that for the application of the Retail Transmission Rate – Network Service Rate and the Retail Transmission Rate – Line and Transformation Connection Service Rate the following sub-classifications apply:

General Service 50 to 1,000 kW non-interval metered

General Service 50 to 1,000 kW interval metered

General Service >1,000 to 4,999 kW interval metered.

Unmetered Scattered Load

This classification applies to an account taking electricity at 750 volts or less whose average monthly maximum demand is less than, or is forecast to be less than, 50 kW and the consumption is unmetered. Such connections include cable TV power packs, bus shelters, telephone booths, traffic lights, railway crossings, etc. The level of the consumption will be

SIOUX LOOKOUT HYDRO INC.

agreed to by the distributor and the customer, based on detailed manufacturer information/documentation with regard to electrical consumption of the unmetered load or periodic monitoring of actual consumption.

StreetLights

This classification applies to an account for roadway lighting with a Municipality, Regional Municipality, Ministry of Transportation and private roadway lighting, controlled by photo cells. The consumption for these customers will be based on the calculated connected load times the required lighting times established in the approved OEB street lighting load shape template.

SIOUX LOOKOUT HYDRO INC.**EXISTING RATE SCHEDULE****Residential**

Service Charge	\$	20.30
Distribution Volumetric Rate	\$/kWh	0.0087
Regulatory Asset Recovery	\$/kWh	0.0106
Retail Transmission Rate – Network Service Rate	\$/kWh	0.0057
Retail Transmission Rate – Line and Transformation Connection Service Rate	\$/kWh	0.0050
Wholesale Market Service Rate	/kWh	0.0052
Rural Rate Protection Charge	\$/kWh	0.0010
Standard Supply Service – Administrative Charge (if applicable)	\$	0.25

General Service Less Than 50 kW

Service Charge	\$	36.05
Distribution Volumetric Rate	\$/kWh	0.0068
Regulatory Asset Recovery	\$/kWh	0.0104
Retail Transmission Rate – Network Service Rate	\$/kWh	0.0052
Retail Transmission Rate – Line and Transformation Connection Service Rate	\$/kWh	0.0045
Wholesale Market Service Rate	/kWh	0.0052
Rural Rate Protection Charge	\$/kWh	0.0010
Standard Supply Service – Administrative Charge (if applicable)	\$	0.25

General Service 50 to 4,999 kW

Service Charge	\$	414.94
Distribution Volumetric Rate	\$/kW	1.4391
Regulatory Asset Recovery	\$/kW	4.2041
Retail Transmission Rate – Network Service Rate	\$/kW	2.1218
Retail Transmission Rate – Line and Transformation Connection Service Rate	\$/kW	1.7882
Retail Transmission Rate – Network Service Rate – Interval Metered	\$/kW	2.2535
Retail Transmission Rate – Line and Transformation Connection Service Rate – Interval Metered	\$/kW	1.9603
Retail Transmission Rate – Network Service Rate – Interval Metered >1,000 kW	\$/kW	2.2508
Retail Transmission Rate – Line and Transformation Connection Service Rate – Interval Metered >1,000 kW	\$/kW	1.9763
Wholesale Market Service Rate	/kWh	0.0052
Rural Rate Protection Charge	\$/kWh	0.0010
Standard Supply Service – Administrative Charge (if applicable)	\$	0.25

Unmetered Scattered Load

Service Charge (per connection)	\$	17.90
Distribution Volumetric Rate	\$/kWh	0.0068
Regulatory Asset Recovery	\$/kWh	0.0104
Retail Transmission Rate – Network Service Rate	\$/kWh	0.0052
Retail Transmission Rate – Line and Transformation Connection Service Rate	\$/kWh	0.0045
Wholesale Market Service Rate	/kWh	0.0052
Rural Rate Protection Charge	\$/kWh	0.0010
Standard Supply Service – Administrative Charge (if applicable)	\$	0.25

Street Lighting

Service Charge (per connection)	\$	0.87
Distribution Volumetric Rate	\$/kW	2.2980
Regulatory Asset Recovery	\$/kW	2.7359
Retail Transmission Rate – Network Service Rate	\$/kW	1.6002

SIOUX LOOKOUT HYDRO INC.

Retail Transmission Rate – Line and Transformation Connection Service Rate	\$/kW	1.3824
Wholesale Market Service Rate	\$/kWh	0.0052
Rural Rate Protection Charge	\$/kWh	0.0010
Standard Supply Service – Administrative Charge (if applicable)	\$	0.25

Specific Service Charges

Customer Administration		
Statement of Account	\$	15.00
Duplicate invoices for previous billing	\$	15.00
Easement Letter	\$	15.00
Income tax letter	\$	15.00
Credit reference/credit check (plus credit agency costs)	\$	15.00
Returned cheque charge (plus bank charges)	\$	15.00
Charge to certify cheque	\$	15.00
Account set up charge/change of occupancy charge (plus credit agency costs if applicable)	\$	30.00
Meter dispute charge plus Measurement Canada fees (if meter found correct)	\$	30.00
Non-Payment of Account		
Late Payment - per month	%	1.50
Late Payment - per annum	%	19.56
Collection of account charge – no disconnection	\$	30.00
Disconnect/Reconnect Charge - At Meter during Regular Hours	\$	110.00
Disconnect/Reconnect Charge - At Meter after Regular Hours	\$	245.00
Disconnect/Reconnect at pole – during regular hours	\$	245.00
Disconnect/Reconnect at pole – after regular hours	\$	415.00
Install/Remove load control device – during regular hours	\$	110.00
Install/Remove load control device – after regular hours	\$	245.00
Temporary service – installs and remove – overhead – no transformer	\$	500.00
Temporary service – installs and remove – underground – no transformer	\$	300.00
Temporary service – install and remove – overhead – with transformer	\$	1,000.00
Specific Charge for Access to the Power Poles – per pole/year	\$	22.35
Allowances		
Transformer Allowance for Ownership - per kW of billing demand/month	\$/kW	(0.60)
Primary Metering Allowance for transformer losses – applied to measured demand and energy	%	(1.00)

Loss Factor

Total Loss Factor – Secondary Metered Customer < 5,000 kW	1.0547
Total Loss Factor – Secondary Metered Customer > 5,000 kW	N/A
Total Loss Factor – Primary Metered Customer < 5,000 kW	1.0442
Total Loss Factor – Primary Metered Customer > 5,000 Kw	N/A

SIoux LOOKOUT HYDRO INC.

PROPOSED RATE CLASSES IF DIFFERENT THAN EXISTING

As at the date of this application, SLHI is not proposing new rate classes

SIOUX LOOKOUT HYDRO INC.**PROPOSED RATE SCHEDULE****Proposed Rates****MONTHLY RATES AND CHARGES****Residential**

Service Charge	\$	23.15
Distribution Volumetric Rate	\$/kWh	0.0136
Regulatory Asset Recovery/Disposal	\$/kWh	(0.0003)
Retail Transmission Rate – Network Service Rate	\$/kWh	0.0052
Retail Transmission Rate – Line and Transformation Connection Service Rate	\$/kWh	0.0016
Wholesale Market Service Rate	/kWh	0.0052
Rural Rate Protection Charge	\$/kWh	0.0010
Standard Supply Service – Administrative Charge (if applicable)	\$	0.25

General Service Less Than 50 kW

Service Charge	\$	41.32
Distribution Volumetric Rate	\$/kWh	0.0111
Regulatory Asset Recovery/Disposal	\$/kWh	(0.0003)
Retail Transmission Rate – Network Service Rate	\$/kWh	0.0048
Retail Transmission Rate – Line and Transformation Connection Service Rate	\$/kWh	0.0014
Wholesale Market Service Rate	/kWh	0.0052
Rural Rate Protection Charge	\$/kWh	0.0010
Standard Supply Service – Administrative Charge (if applicable)	\$	0.25

General Service 50 to 4,999 kW

Service Charge	\$	473.17
Distribution Volumetric Rate	\$/kW	2.6784
Regulatory Asset Recovery/Disposal	\$/kWh	(0.1407)
Retail Transmission Rate – Network Service Rate	\$/kW	1.9521
Retail Transmission Rate – Line and Transformation Connection Service Rate	\$/kW	0.5633
Retail Transmission Rate – Network Service Rate – Interval Metered	\$/kW	2.0732
Retail Transmission Rate – Line and Transformation Connection Service Rate – Interval Metered	\$/kW	0.6175
Retail Transmission Rate – Network Service Rate – Interval Metered >1,000 kW	\$/kW	2.0707
Retail Transmission Rate – Line and Transformation Connection Service Rate – Interval Metered >1,000 kW	\$/kW	0.6225
Wholesale Market Service Rate	/kWh	0.0052
Rural Rate Protection Charge	\$/kWh	0.0010
Standard Supply Service – Administrative Charge (if applicable)	\$	0.25

Unmetered Scattered Load

Service Charge (per connection)	\$	20.50
Distribution Volumetric Rate	\$/kWh	0.0111
Regulatory Asset Recovery/Disposal	\$/kWh	0.0003
Retail Transmission Rate – Network Service Rate	\$/kWh	0.0048
Retail Transmission Rate – Line and Transformation Connection Service Rate	\$/kWh	0.0014
Wholesale Market Service Rate	/kWh	0.0052
Rural Rate Protection Charge	\$/kWh	0.0010
Standard Supply Service – Administrative Charge (if applicable)	\$	0.25

Street Lighting

SIoux LOOKOUT HYDRO INC.

Service Charge (per connection)	\$	0.99
Distribution Volumetric Rate	\$/kW	3.6063
Regulatory Asset Recovery/Disposal	\$/kWh	0.2396
Retail Transmission Rate – Network Service Rate	\$/kW	1.4722
Retail Transmission Rate – Line and Transformation Connection Service Rate	\$/kW	0.4355
Wholesale Market Service Rate	/kWh	0.0052
Rural Rate Protection Charge	\$/kWh	0.0010
Standard Supply Service – Administrative Charge (if applicable)	\$	0.25
Wholesale Market Service Rate	/kWh	0.0052
Rural Rate Protection Charge	\$/kWh	0.0010
Standard Supply Service – Administrative Charge (if applicable)	\$	0.25

Specific Service Charges

Customer Administration		
Statement of Account	\$	15.00
Duplicate invoices for previous billing	\$	15.00
Easement Letter	\$	15.00
Income tax letter	\$	15.00
Credit reference/credit check (plus credit agency costs)	\$	15.00
Returned cheque charge (plus bank charges)	\$	15.00
Charge to certify cheque	\$	15.00
Account set up charge/change of occupancy charge (plus credit agency costs if applicable)	\$	30.00
Meter dispute charge plus Measurement Canada fees (if meter found correct)	\$	30.00
Non-Payment of Account		
Late Payment - per month	%	1.50
Late Payment - per annum	%	19.56
Collection of account charge – no disconnection	\$	30.00
Disconnect/Reconnect Charge - At Meter during Regular Hours	\$	110.00
Disconnect/Reconnect Charge - At Meter after Regular Hours	\$	245.00
Disconnect/Reconnect at pole – during regular hours	\$	245.00
Disconnect/Reconnect at pole – after regular hours	\$	415.00
Install/Remove load control device – during regular hours	\$	110.00
Install/Remove load control device – after regular hours	\$	245.00
Temporary service – installs and remove – overhead – no transformer	\$	500.00
Temporary service – installs and remove – underground – no transformer	\$	300.00
Temporary service – install and remove – overhead – with transformer	\$	1,000.00
Specific Charge for Access to the Power Poles – per pole/year	\$	22.35
Allowances		
Transformer Allowance for Ownership - per kW of billing demand/month /kW		(0.305)
Primary Metering Allowance for transformer losses – applied to measured demand and energy	%	(1.00)

Loss Factor

Total Loss Factor – Secondary Metered Customer < 5,000 kW	1.0642
Total Loss Factor – Secondary Metered Customer > 5,000 kW	1.0145
Total Loss Factor – Primary Metered Customer < 5,000 kW	1.0535
Total Loss Factor – Primary Metered Customer > 5,000 Kw	1.0045

SIoux LOOKOUT HYDRO INC.**DETERMINATION OF SERVICE REVENUE REQUIREMENT****Determination of Service Revenue Requirements**

OM&A Expenses	\$ 1,145,527
Amortization Expenses	\$ 257,983
Total Distribution Expenses	\$ 1,403,510
Regulated Return On Capital	\$ 466,063
PILs (with gross-up)	\$ 52,134
Service Revenue Requirement	\$ 1,921,709
Less: Revenue Offsets	\$ -174,140
Base Service Revenue Requirement	\$ 1,747,569

Determination of Return on Capital

Test Year Balances, Fixed Assets in Service:

Opening Balance	\$ 4,808,989.47
Closing Balance	\$ 5,202,895.81
Average Balance	\$ 5,005,942.64
Working Capital Allowance	\$ 1,464,714.90
Total Rate Base	\$ 6,470,657.54
Regulated Rate of Return	7.20%
Regulated Return On Capital	\$ 466,063.52
Deemed Interest Expense	\$ 203,864.54
Deemed Return on Equity	\$ 262,198.99

SIOUX LOOKOUT HYDRO INC.**RECONCILIATION OF RATE CLASS REVENUE TO TOTAL REVENUE REQUIREMENT**

SLHI has compared the class revenues based on full cost allocation, and at existing rates. The Table below summarizes this comparison. Column A and column D reflect the implementation of full cost allocation as if each customer class were paying for the actual cost to service that class. Columns BorC and EorF reflect the class revenues if no changes were made to the current rate structure and class allocation of distribution revenue.

As illustrated below, SLHI proposes to maintain the same class allocation as the existing rates.

Cost Allocation Comparison - Dollar Impact

Customer Class	A	B	C	D	E	F	G	H
	Outstanding Base Revenue Requirement %			Outstanding Base Revenue Requirement \$			CDM Revenue Allocation	Total Base Revenue Requirement
	Cost Allocation	Existing Rates	Rate Application	Cost Allocation	Existing Rates	Rate Application		
Residential	57.95%	55.56%	55.56%	1,012,687	970,929	970,949	0	970,949
GS <50	19.27%	18.34%	18.34%	336,804	320,453	320,504	0	320,504
GS>50-Regular	14.64%	25.34%	25.34%	255,798	442,849	442,834	0	442,834
Street Light Unmetered	7.95%	0.58%	0.58%	138,900	10,206	10,136	0	10,136
Scattered Load	0.19%	0.18%	0.18%	3,379	3,132	3,146	0	3,146
TOTAL	100.00%	100.00%	100.00%	1,747,569	1,747,569	1,747,569	0	1,747,569

SIOUX LOOKOUT HYDRO INC.

RATE IMPACTS

This exhibit presents the results of the assessment of customer total bill impacts by level of consumption by customer per rate class and per the total customer class.

Impacts are derived using the applicable May 1, 2006 rates and the proposed 2008 distribution rates, (including Rate Rider for the recovery of Regulatory Asset Variance Accounts) and maintaining the 2006 Retail Transmission Service Rates at existing 2006 levels.

The total bill impacts are calculated for the average customer per residential rate class and for General Service Classes at certain levels of consumption. The rates are assessed on the basis of moving to the proposed distribution rates derived in Exhibit 9, Tab 1, Schedule 8, including the Rate Rider for the recovery of regulatory asset variance accounts derived in Exhibit 5, Tab 3, Schedule 3. The total bill impacts are premised on the distribution rates arising from the new revenue requirements. All other non-distribution charges, except RTSR charges, are kept unchanged.

The bill impact excludes Commodity prices.

Residential

100	kWh Consumption	-	-	-
-----	--------------------	---	---	---

SIOUX LOOKOUT HYDRO INC.

Monthly Service Charge				20.30			23.15	2.85	14.0%	6.1%
Distribution	kWh	250	0.0087 0	2.18	250	0.01360	3.40	1.23	56.3%	2.6%
Sub-Total				22.48			26.55	4.08	18.1%	8.7%
Regulatory Asset Recovery	kWh	250	0.0106 0	2.65	250	-	-0.08	-2.73	-	-5.8%
Retail Transmission - Network	kWh	264	0.0057 0	1.50	266	0.00520	1.38	-0.12	-8.0%	-0.3%
Retail Transmission - Line and Transformation Connection	kWh	264	0.0050 0	1.32	266	0.00160	0.43	-0.89	-67.7%	-1.9%
Wholesale Market Service	kWh	264	0.0052 0	1.37	266	0.00520	1.38	0.01	0.9%	0.0%
Rural Rate Protection Charge	kWh	264	0.0010 0	0.26	266	0.00100	0.27	0.00	0.9%	0.0%
Debt Retirement Charge	kWh	250	0.0070 0	1.75	250	0.00700	1.75	0.00	0.0%	0.0%
Cost of Power Commodity	kWh	264	0.0570 4	15.04	266	0.05704	15.18	0.14	0.9%	0.3%
Total Bill				46.37			46.86	0.49	1.1%	1.0%

Residential

500 kWh Consumption

	Metric	2007 BILL			2008 BILL			IMPACT		
		Volume	Rate \$	Charge \$	Volume	Rate \$	Charge \$	Change \$	Change %	% of Total Bill
Monthly Service Charge				20.30			23.15	2.85	14.0%	4.0%
Distribution	kWh	500	0.0087 0	4.35	500	0.01360	6.80	2.45	56.3%	3.5%
Sub-Total				24.65			29.95	5.30	21.5%	7.5%

SIOUX LOOKOUT HYDRO INC.

Regulatory Asset Recovery	kWh	500	0.0106 0	5.30	500	-	0.00030	-0.15	-5.45	-	102.8%	-7.7%
Retail Transmission - Network	kWh	527	0.0057 0	3.01	532	0.00520	2.77	-0.24	-8.0%	-0.3%		
Retail Transmission - Line and Transformation Connection	kWh	527	0.0050 0	2.64	532	0.00160	0.85	-1.79	-67.7%	-2.5%		
Wholesale Market Service	kWh	527	0.0052 0	2.74	532	0.00520	2.77	0.02	0.9%	0.0%		
Rural Rate Protection Charge	kWh	527	0.0010 0	0.53	532	0.00100	0.53	0.00	0.9%	0.0%		
Debt Retirement Charge	kWh	500	0.0070 0	3.50	500	0.00700	3.50	0.00	0.0%	0.0%		
Cost of Power Commodity	kWh	527	0.0570 4	30.08	532	0.05704	30.35	0.27	0.9%	0.4%		
Total Bill				72.44				70.57	-1.87	-2.6%	-2.7%	

Residential

750 kWh Consumption

	Metric	2007 BILL			2008 BILL			IMPACT				
		Volume	Rate \$	Charge \$	Volume	Rate \$	Charge \$	Change \$	Change %	% of Total Bill		
Monthly Service Charge				20.30			23.15	2.85	14.0%	3.0%		
Distribution	kWh	750	0.0087 0	6.53	750	0.01360	10.20	3.68	56.3%	3.9%		
Sub-Total				26.83			33.35	6.53	24.3%	6.9%		
Regulatory Asset Recovery	kWh	750	0.0106 0	7.95	750	-	0.00030	-0.23	-8.18	-	102.8%	-8.7%
Retail Transmission - Network	kWh	791	0.0057 0	4.51	798	0.00520	4.15	-0.36	-8.0%	-0.4%		

SIOUX LOOKOUT HYDRO INC.

Retail Transmission - Line and Transformation Connection	kWh	791	0.0050 0	3.96	798	0.00160	1.28	-2.68	-67.7%	-2.8%
Wholesale Market Service	kWh	791	0.0052 0	4.11	798	0.00520	4.15	0.04	0.9%	0.0%
Rural Rate Protection Charge	kWh	791	0.0010 0	0.79	798	0.00100	0.80	0.01	0.9%	0.0%
Debt Retirement Charge	kWh	750	0.0070 0	5.25	750	0.00700	5.25	0.00	0.0%	0.0%
Cost of Power Commodity	kWh	791	0.0570 4	45.12	798	0.05704	45.53	0.41	0.9%	0.4%
Total Bill				98.51			94.28	-4.24	-4.3%	-4.5%

Residential

1,000 kWh Consumption

	Metric	2007 BILL			2008 BILL			IMPACT		
		Volume	Rate \$	Charge \$	Volume	Rate \$	Charge \$	Change \$	Change %	% of Total Bill
Monthly Service Charge				20.30			23.15	2.85	14.0%	2.4%
Distribution	kWh	1,000	0.0087 0	8.70	1,000	0.01360	13.60	4.90	56.3%	4.2%
				29.00			36.75	7.75	26.7%	6.6%
Regulatory Asset Recovery	kWh	1,000	0.0106 0	10.60	1,000	-	0.00030	-10.90	-	102.8%
Retail Transmission - Network	kWh	1,055	0.0057 0	6.01	1,064	0.00520	5.53	-0.48	-8.0%	-0.4%
Retail Transmission - Line and Transformation Connection	kWh	1,055	0.0050 0	5.27	1,064	0.00160	1.70	-3.57	-67.7%	-3.0%
Wholesale Market Service	kWh	1,055	0.0052 0	5.48	1,064	0.00520	5.53	0.05	0.9%	0.0%

SIOUX LOOKOUT HYDRO INC.

Rural Rate Protection Charge	kWh	1,055	0.0010 0	1.05	1,064	0.00100	1.06	0.01	0.9%	0.0%
Debt Retirement Charge	kWh	1,000	0.0070 0	7.00	1,000	0.00700	7.00	0.00	0.0%	0.0%
Cost of Power Commodity	kWh	1,055	0.0570 4	60.16	1,064	0.05704	60.70	0.54	0.9%	0.5%
Total Bill				124.58			117.99	-6.60	-5.3%	-5.6%

Residential

1,500 kWh Consumption

	Metric	2007 BILL			2008 BILL			IMPACT		
		Volume	Rate \$	Charge \$	Volume	Rate \$	Charge \$	Change \$	Change %	% of Total Bill
Monthly Service Charge				20.30			23.15	2.85	14.0%	1.7%
Distribution	kWh	1,500	0.0087 0	13.05	1,500	0.01360	20.40	7.35	56.3%	4.4%
Sub-Total				33.35			43.55	10.20	30.6%	6.2%
Regulatory Asset Recovery	kWh	1,500	0.0106 0	15.90	1,500	-	-0.45	-16.35	102.8%	-9.9%
Retail Transmission - Network	kWh	1,582	0.0057 0	9.02	1,596	0.00520	8.30	-0.72	-8.0%	-0.4%
Retail Transmission - Line and Transformation Connection	kWh	1,582	0.0050 0	7.91	1,596	0.00160	2.55	-5.36	-67.7%	-3.2%
Wholesale Market Service	kWh	1,582	0.0052 0	8.23	1,596	0.00520	8.30	0.07	0.9%	0.0%
Rural Rate Protection Charge	kWh	1,582	0.0010 0	1.58	1,596	0.00100	1.60	0.01	0.9%	0.0%
Debt Retirement Charge	kWh	1,500	0.0070 0	10.50	1,500	0.00700	10.50	0.00	0.0%	0.0%

SIOUX LOOKOUT HYDRO INC.

Cost of Power Commodity	kWh	1,582	0.0570 4	90.24	1,596	0.05704	91.05	0.81	0.9%	0.5%
Total Bill				176.73			165.40	-11.32	-6.4%	-6.8%

Residential

2,000 kWh Consumption

	Metric	2007 BILL			2008 BILL			IMPACT		
		Volume	Rate \$	Charge \$	Volume	Rate \$	Charge \$	Change \$	Change %	% of Total Bill
Monthly Service Charge				20.30			23.15	2.85	14.0%	1.3%
Distribution	kWh	2,000	0.0087 0	17.40	2,000	0.01360	27.20	9.80	56.3%	4.6%
Sub-Total				37.70			50.35	12.65	33.6%	5.9%
Regulatory Asset Recovery	kWh	2,000	0.0106 0	21.20	2,000	-	-0.60	-21.80	-	-
Retail Transmission - Network	kWh	2,109	0.0057 0	12.02	2,128	0.00520	11.07	-0.96	-8.0%	-0.4%
Retail Transmission - Line and Transformation Connection	kWh	2,109	0.0050 0	10.55	2,128	0.00160	3.41	-7.14	-67.7%	-3.4%
Wholesale Market Service	kWh	2,109	0.0052 0	10.97	2,128	0.00520	11.07	0.10	0.9%	0.0%
Rural Rate Protection Charge	kWh	2,109	0.0010 0	2.11	2,128	0.00100	2.13	0.02	0.9%	0.0%
Debt Retirement Charge	kWh	2,000	0.0070 0	14.00	2,000	0.00700	14.00	0.00	0.0%	0.0%
Cost of Power Commodity	kWh	2,109	0.0570 4	120.32	2,128	0.05704	121.40	1.08	0.9%	0.5%
Total Bill				228.87			212.82	-16.05	-7.0%	-7.5%

SIOUX LOOKOUT HYDRO INC.

GS <50

1,000

kWh
Consumption

- - -

	Metric	2007 BILL			2008 BILL			IMPACT		
		Volume	Rate \$	Charge \$	Volume	Rate \$	Charge \$	Change \$	Change %	% of Total Bill
Monthly Service Charge				36.05			41.32	5.27	14.6%	4.0%
Distribution	kWh	1,000	0.00680	6.80	1,000	0.01110	11.10	4.30	63.2%	3.2%
Sub-Total				42.85			52.42	9.57	22.3%	7.2%
Regulatory Asset Recovery	kWh	1,000	0.01040	10.40	1,000	0.00030	-0.30	-10.70	102.9%	-8.0%
Retail Transmission - Network	kWh	1,055	0.00520	5.48	1,064	0.00480	5.11	-0.38	-6.9%	-0.3%
Retail Transmission - Line and Transformation Connection	kWh	1,055	0.00450	4.75	1,064	0.00140	1.49	-3.26	-68.6%	-2.4%
Wholesale Market Service	kWh	1,055	0.00520	5.48	1,064	0.00520	5.53	0.05	0.9%	0.0%
Rural Rate Protection Charge	kWh	1,055	0.00100	1.05	1,064	0.00100	1.06	0.01	0.9%	0.0%
Debt Retirement Charge	kWh	1,000	0.00700	7.00	1,000	0.00700	7.00	0.00	0.0%	0.0%
Cost of Power Commodity	kWh	1,055	0.05704	60.16	1,064	0.05704	60.70	0.54	0.9%	0.4%
Total Bill				137.18			133.02	-4.16	-3.0%	-3.1%

GS <50

2,000

kWh
Consumption

- - -

SIOUX LOOKOUT HYDRO INC.

	Metric	2007 BILL			2008 BILL			IMPACT		
		Volume	Rate \$	Charge \$	Volume	Rate \$	Charge \$	Change \$	Change %	% of Total Bill
Monthly Service Charge				36.05			41.32	5.27	14.6%	2.3%
Distribution	kWh	2,000	0.00680	13.60	2,000	0.01110	22.20	8.60	63.2%	3.8%
Sub-Total				49.65			63.52	13.87	27.9%	6.2%
Regulatory Asset Recovery	kWh	2,000	0.01040	20.80	2,000	-	-0.60	-21.40	-	-9.5%
Retail Transmission - Network	kWh	2,109	0.00520	10.97	2,128	0.00480	10.22	-0.75	-6.9%	-0.3%
Retail Transmission - Line and Transformation Connection	kWh	2,109	0.00450	9.49	2,128	0.00140	2.98	-6.51	-68.6%	-2.9%
Wholesale Market Service	kWh	2,109	0.00520	10.97	2,128	0.00520	11.07	0.10	0.9%	0.0%
Rural Rate Protection Charge	kWh	2,109	0.00100	2.11	2,128	0.00100	2.13	0.02	0.9%	0.0%
Debt Retirement Charge	kWh	2,000	0.00700	14.00	2,000	0.00700	14.00	0.00	0.0%	0.0%
Cost of Power Commodity	kWh	2,109	0.05704	120.32	2,128	0.05704	121.40	1.08	0.9%	0.5%
Total Bill				238.31			224.72	-13.59	-5.7%	-6.0%

GS <50

5,000 kWh Consumption

	2007 BILL	2008 BILL	IMPACT
--	-----------	-----------	--------

SIOUX LOOKOUT HYDRO INC.

	Metri c	Volume	Rate \$	Charge \$	Volume	Rate \$	Charge \$	Change \$	Chang e %	% of Total Bill
Monthly Service Charge				36.05			41.32	5.27	14.6%	1.1%
Distribution	kWh	5,000	0.0068 0	34.00	5,000	0.01110	55.50	21.50	63.2%	4.3%
Sub-Total				70.05			96.82	26.77	38.2%	5.4%
Regulatory Asset Recovery	kWh	5,000	0.0104 0	52.00	5,000	-	-1.50	-53.50	102.9%	10.7%
Retail Transmission - Network	kWh	5,274	0.0052 0	27.42	5,321	0.00480	25.54	-1.88	-6.9%	-0.4%
Retail Transmission - Line and Transformation Connection	kWh	5,274	0.0045 0	23.73	5,321	0.00140	7.45	-16.28	-68.6%	-3.3%
Wholesale Market Service	kWh	5,274	0.0052 0	27.42	5,321	0.00520	27.67	0.25	0.9%	0.0%
Rural Rate Protection Charge	kWh	5,274	0.0010 0	5.27	5,321	0.00100	5.32	0.05	0.9%	0.0%
Debt Retirement Charge	kWh	5,000	0.0070 0	35.00	5,000	0.00700	35.00	0.00	0.0%	0.0%
Cost of Power Commodity	kWh	5,274	0.0570 4	300.80	5,321	0.05704	303.51	2.71	0.9%	0.5%
Total Bill				541.70			499.81	-41.89	-7.7%	-8.4%

GS <50

10,000 kWh Consumption

	Metri c	2007 BILL			2008 BILL			IMPACT		
		Volume	Rate \$	Charge \$	Volume	Rate \$	Charge \$	Change \$	Chang e %	% of Total Bill
Monthly Service Charge				36.05			41.32	5.27	14.6%	0.5%

SIOUX LOOKOUT HYDRO INC.

Distribution	kWh	10,000	0.0068 0	68.00	10,000	0.01110	111.00	43.00	63.2%	4.5%
Sub-Total				104.05			152.32	48.27	46.4%	5.0%
Regulatory Asset Recovery	kWh	10,000	0.0104 0	104.00	10,000	-	-3.00	-107.00	-	-
Retail Transmission - Network	kWh	10,547	0.0052 0	54.84	10,642	0.00480	51.08	-3.76	-6.9%	-0.4%
Retail Transmission - Line and Transformation Connection	kWh	10,547	0.0045 0	47.46	10,642	0.00140	14.90	-32.56	-68.6%	-3.4%
Wholesale Market Service	kWh	10,547	0.0052 0	54.84	10,642	0.00520	55.34	0.49	0.9%	0.1%
Rural Rate Protection Charge	kWh	10,547	0.0010 0	10.55	10,642	0.00100	10.64	0.09	0.9%	0.0%
Debt Retirement Charge	kWh	10,000	0.0070 0	70.00	10,000	0.00700	70.00	0.00	0.0%	0.0%
Cost of Power Commodity	kWh	10,547	0.0570 4	601.60	10,642	0.05704	607.02	5.42	0.9%	0.6%
Total Bill				1,047.35			958.30	-89.05	-8.5%	-9.3%

GS <50

	kWh	-	-	-
15,000	Consumption	-	-	-

	Metric	2007 BILL			2008 BILL			IMPACT		
		Volume	Rate \$	Charge \$	Volume	Rate \$	Charge \$	Change \$	Change %	% of Total Bill
Monthly Service Charge				36.05			41.32	5.27	14.6%	0.4%
Distribution	kWh	15,000	0.0068 0	102.00	15,000	0.01110	166.50	64.50	63.2%	4.6%
Sub-Total				138.05			207.82	69.77	50.5%	4.9%
Regulatory Asset Recovery	kWh	15,000	0.0104	156.00	15,000	-	-4.50	-160.50	-	-

SIOUX LOOKOUT HYDRO INC.

			0			0.00030		102.9%	11.3%	
Retail Transmission - Network	kWh	15,821	0.0052 0	82.27	15,963	0.00480	76.62	-5.64	-6.9%	-0.4%
Retail Transmission - Line and Transformation Connection	kWh	15,821	0.0045 0	71.19	15,963	0.00140	22.35	-48.84	-68.6%	-3.4%
Wholesale Market Service	kWh	15,821	0.0052 0	82.27	15,963	0.00520	83.01	0.74	0.9%	0.1%
Rural Rate Protection Charge	kWh	15,821	0.0010 0	15.82	15,963	0.00100	15.96	0.14	0.9%	0.0%
Debt Retirement Charge	kWh	15,000	0.0070 0	105.00	15,000	0.00700	105.00	0.00	0.0%	0.0%
Cost of Power Commodity	kWh	15,821	0.0570 4	902.40	15,963	0.05704	910.53	8.13	0.9%	0.6%
Total Bill				1,553.00			1,416.79	-136.21	-8.8%	-9.6%

GS>50-Regular

60 kW Consumption
 15,000 kWh Consumption

	Metric	2007 BILL			2008 BILL			IMPACT		
		Volume	Rate \$	Charge \$	Volume	Rate \$	Charge \$	Change \$	Change %	% of Total Bill
Monthly Service Charge				414.94			473.17	58.23	14.0%	3.1%
Distribution	kW	60	1.4391 0	86.35	60	2.67840	160.70	74.36	86.1%	3.9%
Sub-Total				501.29			633.87	132.59	26.4%	7.0%
Regulatory Asset Recovery	kW	60	4.2041 0	252.25	60	-	-8.44	-260.69	-	-
Retail Transmission - Network	kW	63	2.1218 0	134.27	64	1.95210	124.65	-9.63	103.3%	13.7%

SIOUX LOOKOUT HYDRO INC.

Retail Transmission - Line and Transformation Connection	kW	63	1.7882 0	113.16	64	0.56330	35.97	-77.19	-68.2%	-4.1%
Wholesale Market Service	kWh	15,821	0.0052 0	82.27	15,963	0.00520	83.01	0.74	0.9%	0.0%
Rural Rate Protection Charge	kWh	15,821	0.0010 0	15.82	15,963	0.00100	15.96	0.14	0.9%	0.0%
Debt Retirement Charge	kWh	15,000	0.0070 0	105.00	15,000	0.00700	105.00	0.00	0.0%	0.0%
Cost of Power Commodity	kWh	15,821	0.0570 4	902.40	15,963	0.05704	910.53	8.13	0.9%	0.4%
Total Bill				2,106.45			1,900.55	-205.91	-9.8%	-10.8%

GS>50-Regular

100 kW Consumption
 40,000 kWh Consumption

	Metric	2007 BILL			2008 BILL			IMPACT		
		Volume	Rate \$	Charge \$	Volume	Rate \$	Charge \$	Change \$	Change %	% of Total Bill
Monthly Service Charge				414.94			473.17	58.23	14.0%	1.5%
Distribution	kW	100	1.4391 0	143.91	100	2.67840	267.84	123.93	86.1%	3.1%
Sub-Total				558.85			741.01	182.16	32.6%	4.6%
Regulatory Asset Recovery	kW	100	4.2041 0	420.41	100	-	-14.07	-434.48	-	-
Retail Transmission - Network	kW	100	2.1218 0	212.18	106	1.95210	207.74	-4.44	-2.1%	-0.1%
Retail Transmission - Line and Transformation Connection	kW	100	1.7882 0	178.82	106	0.56330	59.95	-118.87	-66.5%	-3.0%

SIOUX LOOKOUT HYDRO INC.

Wholesale Market Service	kWh	42,188	0.0052 0	219.38	42,568	0.00520	221.35	1.98	0.9%	0.0%
Rural Rate Protection Charge	kWh	42,188	0.0010 0	42.19	42,568	0.00100	42.57	0.38	0.9%	0.0%
Debt Retirement Charge	kWh	40,000	0.0070 0	280.00	40,000	0.00700	280.00	0.00	0.0%	0.0%
Cost of Power Commodity	kWh	42,188	0.0570 4	2,406.40	42,568	0.05704	2,428.08	21.68	0.9%	0.5%
Total Bill				4,318.23			3,966.63	-351.60	-8.1%	-8.9%

GS>50-Regular

500 kW Consumption
 100,000 kWh Consumption

	Metric	2007 BILL			2008 BILL			IMPACT		
		Volume	Rate \$	Charge \$	Volume	Rate \$	Charge \$	Change \$	Change %	% of Total Bill
Monthly Service Charge				414.94			473.17	58.23	14.0%	0.6%
Distribution	kW	500	1.4391 0	719.55	500	2.67840	1,339.20	619.65	86.1%	5.9%
Sub-Total				1,134.49			1,812.37	677.88	59.8%	6.4%
Regulatory Asset Recovery	kW	500	4.2041 0	2,102.05	500	- 0.14070	-70.35	-2,172.40	-	-
Retail Transmission - Network	kW	527	2.1218 0	1,118.93	532	1.95210	1,038.71	-80.22	-7.2%	-0.8%
Retail Transmission - Line and Transformation Connection	kW	527	1.7882 0	943.01	532	0.56330	299.73	-643.28	-68.2%	-6.1%
Wholesale Market Service	kWh	105,470	0.0052 0	548.44	106,420	0.00520	553.38	4.94	0.9%	0.0%
Rural Rate Protection Charge	kWh	105,470	0.0010	105.47	106,420	0.00100	106.42	0.95	0.9%	0.0%

SIOUX LOOKOUT HYDRO INC.

Debt Retirement Charge	kWh	100,000	0.0070 0	700.00	100,000	0.00700	700.00	0.00	0.0%	0.0%
Cost of Power Commodity	kWh	105,470	0.0570 4	6,016.01	106,420	0.05704	6,070.20	54.19	0.9%	0.5%
Total Bill				12,668.40			10,510.47	-2,157.94	-17.0%	-20.5%

GS>50-Regular

1,000	kW Consumption	-	-	-
	kWh	-	-	-
400,000	Consumption	-	-	-

	Metric	2007 BILL			2008 BILL			IMPACT		
		Volume	Rate \$	Charge \$	Volume	Rate \$	Charge \$	Change \$	Change %	% of Total Bill
Monthly Service Charge				414.94			473.17	58.23	14.0%	0.2%
Distribution	kW	1,000	1.4391 0	1,439.10	1,000	2.67840	2,678.40	1,239.30	86.1%	3.5%
Sub-Total				1,854.04			3,151.57	1,297.53	70.0%	3.7%
Regulatory Asset Recovery	kW	1,000	4.2041 0	4,204.10	1,000	0.14070	-140.70	-4,344.80	103.3%	12.3%
Retail Transmission - Network	kW	1,055	2.1218 0	2,237.86	1,064	1.95210	2,077.42	-160.44	-7.2%	-0.5%
Retail Transmission - Line and Transformation Connection	kW	1,055	1.7882 0	1,886.01	1,064	0.56330	599.46	-1,286.55	-68.2%	-3.6%
Wholesale Market Service	kWh	421,880	0.0052 0	2,193.78	425,680	0.00520	2,213.54	19.76	0.9%	0.1%
Rural Rate Protection Charge	kWh	421,880	0.0010 0	421.88	425,680	0.00100	425.68	3.80	0.9%	0.0%
Debt Retirement Charge	kWh	400,000	0.0070	2,800.00	400,000	0.00700	2,800.00	0.00	0.0%	0.0%

SIoux LOOKOUT HYDRO INC.

Cost of Power Commodity	kWh	421,880	0 0.0570 4	24,064.04	425,680	0.05704	24,280.79	216.75	0.9%	0.6%
Total Bill				39,661.71			35,407.76	-4,253.95	-10.7%	-12.0%

GS>50-Regular

3,000 kW Consumption
 kWh
 1,000,000 Consumption

	Metric	2007 BILL			2008 BILL			IMPACT		
		Volume	Rate \$	Charge \$	Volume	Rate \$	Charge \$	Change \$	Change %	% of Total Bill
Monthly Service Charge				414.94			473.17	58.23	14.0%	0.1%
Distribution	kW	3,000	1.4391 0	4,317.30	3,000	2.67840	8,035.20	3,717.90	86.1%	4.1%
Sub-Total				4,732.24			8,508.37	3,776.13	79.8%	4.2%
Regulatory Asset Recovery	kW	3,000	4.2041 0	12,612.30	3,000	-	-422.10	13,034.40	103.3%	14.4%
Retail Transmission - Network	kW	3,164	2.1218 0	6,713.59	3,193	1.95210	6,232.27	-481.31	-7.2%	-0.5%
Retail Transmission - Line and Transformation Connection	kW	3,164	1.7882 0	5,658.04	3,193	0.56330	1,798.39	-3,859.65	-68.2%	-4.3%
Wholesale Market Service	kWh	1,054,700	0.0052 0	5,484.44	1,064,200	0.00520	5,533.84	49.40	0.9%	0.1%
Rural Rate Protection Charge	kWh	1,054,700	0.0010 0	1,054.70	1,064,200	0.00100	1,064.20	9.50	0.9%	0.0%
Debt Retirement Charge	kWh	1,000,000	0.0070 0	7,000.00	1,000,000	0.00700	7,000.00	0.00	0.0%	0.0%
Cost of Power Commodity	kWh	1,054,700	0.0570	60,160.09	1,064,200	0.05704	60,701.97	541.88	0.9%	0.6%

SIOUX LOOKOUT HYDRO INC.

		4			
Total Bill		103,415.40		90,416.94	-12.6%
				12,998.45	14.4%

Large Use >5MW

6,000	kW Consumption	-	-	-
	kWh	-	-	-
2,800,000	Consumption	-	-	-

	Metric	2007 BILL			2008 BILL			IMPACT		
		Volume	Rate \$	Charge \$	Volume	Rate \$	Charge \$	Change \$	Change %	% of Total Bill
Monthly Service Charge										
Distribution	kW	6,000			6,000	0.00000	0.00			
Sub-Total				0.00			0.00	0.00		0.0%
Regulatory Asset Recovery	kW	6,000			6,000	0.00000	0.00			
Retail Transmission - Network	kW	0			0	0.00000	0.00			
Retail Transmission - Line and Transformation Connection	kW	0			0	0.00000	0.00			
Wholesale Market Service	kWh	0			0	0.00000	0.00			
Rural Rate Protection Charge	kWh	0			0	0.00000	0.00			
Debt Retirement Charge	kWh	2,800,000	0.00700	19,600.00	2,800,000	0.00700	19,600.00	0.00	0.0%	0.0%
Cost of Power Commodity	kWh	0	0.05704	0.00	0	0.05704	0.00	0.00		0.0%
Total Bill				19,600.00			19,600.00	0.00	0.0%	0.0%

Large Use >5MW

-	-	-
---	---	---

SIoux LOOKOUT HYDRO INC.

15,000 kW Consumption
 kWh
 10,000,000 Consumption

	Metric	2007 BILL			2008 BILL			IMPACT		
		Volume	Rate \$	Charge \$	Volume	Rate \$	Charge \$	Change \$	Change %	% of Total Bill
Monthly Service Charge Distribution	kW	15,000			15,000	0.00000	0.00			
Sub-Total				0.00			0.00	0.00		0.0%
Regulatory Asset Recovery	kW	15,000			15,000	0.00000	0.00			
Retail Transmission - Network	kW	0			0	0.00000	0.00			
Retail Transmission - Line and Transformation Connection	kW	0			0	0.00000	0.00			
Wholesale Market Service	kWh	0			0	0.00000	0.00			
Rural Rate Protection Charge	kWh	0			0	0.00000	0.00			
Debt Retirement Charge	kWh	10,000,000	0.00700	70,000.00	10,000,000	0.00700	70,000.00	0.00	0.0%	0.0%
Cost of Power Commodity	kWh	0	0.05704	0.00	0	0.05704	0.00	0.00		0.0%
Total Bill				70,000.00			70,000.00	0.00	0.0%	0.0%

Large Use >5MW

30,000 kW Consumption
 kWh
 20,000,000 Consumption

		2007 BILL	2008 BILL	IMPACT
--	--	-----------	-----------	--------

SIOUX LOOKOUT HYDRO INC.

	Metri c	Volume	Rate \$	Charge \$	Volume	Rate \$	Charge \$	Change \$	Chang e %	% of Total Bill
Monthly Service Charge							0.00			
Distribution	kW	30,000			30,000	0.00000	0.00			
Sub-Total				0.00			0.00	0.00		0.0%
Regulatory Asset Recovery	kW	30,000			30,000	0.00000	0.00			
Retail Transmission - Network	kW	0			0	0.00000	0.00			
Retail Transmission - Line and Transformation Connection	kW	0			0	0.00000	0.00			
Wholesale Market Service	kWh	0			0	0.00000	0.00			
Rural Rate Protection Charge	kWh	0			0	0.00000	0.00			
Debt Retirement Charge	kWh	20,000,000	0.0070	140,000.00	20,000,000	0.00700	140,000.00	0.00	0.0%	0.0%
Cost of Power Commodity	kWh	0	0.05704	0.00	0	0.05704	0.00	0.00		0.0%
Total Bill				140,000.00			140,000.00	0.00	0.0%	0.0%

Large Use >5MW

100,000 kW Consumption
53,000,000 kWh Consumption

	Metri c	2007 BILL			2008 BILL			IMPACT		
		Volume	Rate \$	Charge \$	Volume	Rate \$	Charge \$	Change \$	Chang e %	% of Total Bill
Monthly Service Charge							0.00			
Distribution	kW	100,000			100,000	0.00000	0.00			

SIOUX LOOKOUT HYDRO INC.

Sub-Total		0.00			0.00			0.00	0.0%	
Regulatory Asset Recovery	kW	100,000			100,000	0.00000	0.00			
Retail Transmission - Network	kW	0			0	0.00000	0.00			
Retail Transmission - Line and Transformation Connection	kW	0			0	0.00000	0.00			
Wholesale Market Service	kWh	0			0	0.00000	0.00			
Rural Rate Protection Charge	kWh	0			0	0.00000	0.00			
Debt Retirement Charge	kWh	53,000.00	0.0070	371,000.0	53,000.00	0.00700	371,000.0	0.00	0.0%	0.0%
		0	0	0	0		0			
Cost of Power Commodity	kWh	0	0.0570	0.00	0	0.05704	0.00	0.00		0.0%
			4							
Total Bill				371,000.0			371,000.0	0.00	0.0%	0.0%
				0			0			

Street Light

1	kW Consumption	-	-	-
	kWh			
25	Consumption	-	-	-

	Metric	2007 BILL			2008 BILL			IMPACT		
		Volume	Rate \$	Charge \$	Volume	Rate \$	Charge \$	Change \$	Change %	% of Total Bill
Monthly Service Charge				0.87			0.99	0.12	13.8%	1.7%
Distribution	kW	1	2.2980	1.72	1	3.60630	2.70	0.98	56.9%	13.5%
			0							
Sub-Total				2.59			3.69	1.10	42.5%	15.2%
Regulatory Asset Recovery	kW	1	2.7359	2.05	1	0.23960	0.18	-1.87	-91.2%	-
			0							25.8%
Retail Transmission - Network	kW	1	1.6002	1.27	1	1.47220	1.18	-0.09	-7.2%	-1.3%
			0							

SIoux LOOKOUT HYDRO INC.

Retail Transmission - Line and Transformation Connection	kW	1	1.3824 0	1.09	1	0.43550	0.35	-0.75	-68.2%	- 10.3%
Wholesale Market Service	kWh	26	0.0052 0	0.14	27	0.00520	0.14	0.00	0.9%	0.0%
Rural Rate Protection Charge	kWh	26	0.0010 0	0.03	27	0.00100	0.03	0.00	0.9%	0.0%
Debt Retirement Charge	kWh	25	0.0070 0	0.18	25	0.00700	0.18	0.00	0.0%	0.0%
Cost of Power Commodity	kWh	26	0.0570 4	1.50	27	0.05704	1.52	0.01	0.9%	0.2%
Total Bill				8.85			7.25	-1.59	-18.0%	- 22.0%

Sentinel Lighting

0.75	kW Consumption	-	-	-
	kWh	-	-	-
25	Consumption	-	-	-

	Metric	2007 BILL			2008 BILL			IMPACT		
		Volume	Rate \$	Charge \$	Volume	Rate \$	Charge \$	Change \$	Change %	% of Total Bill
Monthly Service Charge							0.00			
Distribution	kW	1			1	0.00000	0.00			
Sub-Total				0.00			0.00	0.00		0.0%
Regulatory Asset Recovery	kW	1			1	0.00000	0.00			
Retail Transmission - Network	kW	1			1	0.00000	0.00			
Retail Transmission - Line and Transformation Connection	kW	1			1	0.00000	0.00			
Wholesale Market Service	kWh	26			27	0.00000	0.00			
Rural Rate Protection Charge	kWh	26			27	0.00000	0.00			

SIoux LOOKOUT HYDRO INC.

Debt Retirement Charge	kWh	25	0.0070 0	0.18	25	0.00700	0.18	0.00	0.0%	0.0%
Cost of Power Commodity	kWh	26	0.0570 4	1.50	27	0.05704	1.52	0.01	0.9%	0.8%
Total Bill				1.68			1.69	0.01	0.8%	0.8%

Sentinel Lighting

0.75	kW Consumption	-	-	-
	kWh	-	-	-
50	Consumption	-	-	-

	Metric	2007 BILL			2008 BILL			IMPACT		
		Volume	Rate \$	Charge \$	Volume	Rate \$	Charge \$	Change \$	Change %	% of Total Bill
Monthly Service Charge							0.00			
Distribution	kW	1			1	0.00000	0.00			
Sub-Total				0.00			0.00	0.00		0.0%
Regulatory Asset Recovery	kW	1			1	0.00000	0.00			
Retail Transmission - Network	kW	1			1	0.00000	0.00			
Retail Transmission - Line and Transformation Connection	kW	1			1	0.00000	0.00			
Wholesale Market Service	kWh	53			53	0.00000	0.00			
Rural Rate Protection Charge	kWh	53			53	0.00000	0.00			
Debt Retirement Charge	kWh	50	0.0070 0	0.35	50	0.00700	0.35	0.00	0.0%	0.0%
Cost of Power Commodity	kWh	53	0.0570 4	3.01	53	0.05704	3.04	0.03	0.9%	0.8%
Total Bill				3.36			3.39	0.03	0.8%	0.8%

SIOUX LOOKOUT HYDRO INC.

Unmetered Scattered Load

3000	kW Consumption	-	-	-
	kWh			
3000	Consumption	-	-	-

	Metric	2007 BILL			2008 BILL			IMPACT		
		Volume	Rate \$	Charge \$	Volume	Rate \$	Charge \$	Change \$	Change %	% of Total Bill
Monthly Service Charge				17.90			20.61	2.71	15.1%	0.9%
Distribution	kW	3,164	0.00680	21.52	3,000	0.01114	33.43	11.91	55.4%	4.0%
Sub-Total				39.42			54.04	14.62	37.1%	4.9%
Regulatory Asset Recovery	kWh	3,164	0.01040	32.91	3,000	0.00030	0.90	-32.01	-97.3%	-
Retail Transmission - Network	kWh	3,164	0.00520	16.45	3,193	0.00480	15.32	-1.13	-6.9%	-0.4%
Retail Transmission - Line and Transformation Connection	kWh	3,164	0.00450	14.24	3,193	0.00140	4.47	-9.77	-68.6%	-3.3%
Wholesale Market Service	kWh	3,164	0.00520	16.45	3,193	0.00520	16.60	0.15	0.9%	0.0%
Rural Rate Protection Charge	kWh	3,164	0.00100	3.16	3,193	0.00100	3.19	0.03	0.9%	0.0%
Debt Retirement Charge	kWh	3,164	0.00700	22.15	3,000	0.00700	21.00	-1.15	-5.2%	-0.4%
Cost of Power Commodity	kWh	3,164	0.05704	180.48	3,193	0.05704	182.11	1.63	0.9%	0.5%
Total Bill				325.26			297.63	-27.63	-8.5%	-9.3%

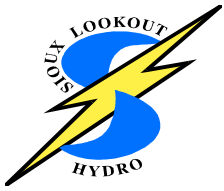

File Number: EB-2007-0785

Exhibit: 9

Tab: 1

Schedule: 10

Page: 1

SIOUX LOOKOUT HYDRO INC.

PROPOSED CHANGES TO TERMS AND CONDITIONS OF SERVICES

Please refer back to Exhibit 1, Tab 2, Schedule 8 for proposed changes to terms and conditions of service