

Attachment A – Proposed Amendments to the Transmission System Code



ONTARIO ENERGY BOARD

Transmission System Code

Last Revised ~~August 26, 2013~~ April 30, 2018

(Originally Issued on July 14, 2000)

TABLE OF CONTENTS

8.1	GUIDELINES OF RELIABILITY ORGANIZATIONS INTENTIONALLY LEFT BLANK
-----	---

2. DEFINITIONS

- 2.0.46 "NERC" means the North American Electric Reliability Council Corporation;
- 2.0.47A "OPA" means the Independent Electricity System Operator or successor company;
- 2.0.55 "reliability organization" means NERC, ~~NERC's reliability councils~~ the Northeast Power Coordinating Council, and the IESO;

6. CUSTOMER CONNECTIONS

6.1 GENERAL REQUIREMENTS

- 6.1.5 ~~Intentionally left blank. A transmitter shall file its connection procedures for the Board's approval within one year of the Code revision date. A transmitter shall also file any material amendments to those procedures for the Board's approval. The transmitter may not give effect to such connection procedures or any material amendments thereto until the connection procedures or amendments have been approved by the Board or amended by the Board under section 6.1.6.~~
- 6.1.6 The Board may, on application or on its own motion, amend a transmitter's connection procedures and any amendments thereto that have been previously approved or amended by the Board.
- 6.1.7 ~~Intentionally left blank. Where, prior to the Code revision date, a transmitter had filed its connection procedures with the Board and such connection procedures do not contain all of the material required by section 6.1.4, the transmitter shall file the missing material within one year of the Code revision date. The Board may make a decision regarding the incomplete connection procedures pending the filing of the missing material.~~
- 6.8.3. Where a transmitter had an executed agreement with a neighbouring Ontario transmitter on August 26, 2013, the parties shall amend that agreement as may be required to ensure that it complies with the requirements of sections 6.8.1 and 6.8.2. Such amendment shall be made as soon as any other amendment to the agreement is being made by the parties and in any event no later than ~~the date that is five years from the Code revision date~~ August 26, 2018.

8 GENERAL TECHNICAL REQUIREMENTS

8.1 ~~GUIDELINES OF RELIABILITY ORGANIZATIONS~~ INTENTIONALLY LEFT BLANK

~~8.1.1 A transmitter shall ensure compliance with the standards of all applicable reliability organizations.~~

~~8.1.2 A transmitter shall provide to a customer, upon request, the name and address of a contact person for each applicable reliability organization.~~

8.2 PROTECTION AND CONTROL

8.2.1 j) the two protection systems shall be supplied either from separate secondary windings of a voltage and current transformer or from separate voltage and current transformers. ~~On one voltage transformer or potential device and from separate current transformer secondary windings (using two current transformers — one current transformer for each protection system); and~~

8.3 INSULATION COORDINATION

8.3.2 The transmitter shall ensure that a A tap connected to a shielded transmission circuit is ~~shall also be shielded.~~

9. TECHNICAL REQUIREMENTS FOR TAPPED TRANSFORMER STATIONS SUPPLYING LOAD

9.1 SUPPLY CONSIDERATIONS

9.1.2 The transmitter shall ensure that the grounding of neutrals of the power transformer primary windings at transmission system tapped transmission system stations are normally not grounded ~~do not adversely affect the reliability of the transmission system.~~

9.2 PROTECTION REQUIREMENTS

9.2.1 The transmitter's protection and teleprotection requirements will be identified

in the connection agreement. These requirements apply to the facilities that interface between the customer and the transmitter systems. Typical technical requirements for a transmitter's tapped transformer stations protection are set out in Exhibit E.1, Schedule E of the applicable version of the connection agreement set out in Appendix 1, and Exhibits F.1 and F.2, Schedule F of version A of the connection agreement set out in Appendix 1.

- 9.2.2 Intentionally left blank. ~~Line protections are required when transformers connected to separate supply circuits are operated in parallel on the low voltage side, or if a large synchronous infeed exists at the low voltage bus.~~
- 9.2.3 Intentionally left blank. ~~Directional current sensing relays may be required to detect infeed into faults within the transmission system and to isolate a tapped transformer station's contribution to the fault. Distance or impedance (21) relays as specified in Exhibit F.2, Schedule F of version A of the connection agreement set out in Appendix 1, may serve this need.~~
- 9.2.4 Intentionally left blank. ~~If the tapped transformer is connected ungrounded wye or delta on the primary, then ground under voltage (64-27) and ground over voltage (64-59) protections as shown in Exhibit F.2, Schedule F of version A of the connection agreement set out in Appendix 1 are required to detect ground faults.~~
- 9.2.5 Intentionally left blank. ~~Where the tapped transformer is connected wye grounded on the primary (Yg/D or Yg/Yg), a ground over current relay (64) as indicated in Exhibit F.2, Schedule F of version A of the connection agreement set out in Appendix 1, connected in the transformer neutral, may be used for detection.~~

10 PROTECTION SYSTEM REQUIREMENTS

10.1 TELECOMMUNICATIONS

- 10.1.2 A transmitter shall specify to all customers telecommunication channel media and protective systems in the connection agreement. These requirements shall apply to the facilities that interface between the customer and the transmitter systems.
- 10.1.4 Intentionally left blank. ~~Where each of the dual protections protecting the same system element requires communication channels, a shall ensure that the equipment and channel for each protections system is separated physically and designed to minimize the risk that both protections might be disabled simultaneously by a single contingency.~~
- 10.1.6 The transmitter shall include a maximum annual specification on major disturbances caused by telecommunication failures in the connection agreement. ~~Major disturbances caused by telecommunication failures shall have annual frequency of less than 0.002 per year from the dependability aspect and less than 0.002 per year from the security aspect.~~
- 10.1.7 The transmitter shall include a maximum annual specification for unavailability of the telecommunication protection for a single transmission system circuit and for two circuits in the connection agreement. ~~A transmitter shall ensure that telecommunication protection for a single transmission system circuit shall be unavailable for no more than 42 minutes per year, and for two circuits, no more than four minutes per year.~~
- 10.1.8 The transmitter shall include a maximum annual specification for telecommunication false trip rate in the connection agreement. ~~A transmitter shall ensure that the telecommunication false trip rate used as part of a protection system for a single transmission system circuit is no more than 0.1 false trips per year, and for two circuits, no more than 0.001 false trips per year.~~
- 10.1.9 The transmitter shall include a maximum annual specification in the connection agreement for total transmission system circuit trips coincident with telecommunications failure. ~~A transmitter shall ensure that total transmission system circuit trips coincident with telecommunications failure are no more than~~

0.001 per year.

10.2 TEST SCHEDULE FOR RELAYING COMMUNICATION CHANNELS

~~10.2.2 Signal adequacy testing for unmonitored channels shall be done at one month intervals. Signal adequacy testing for monitored channels shall be done at twelve month intervals.~~

~~10.2.3 Channel performance testing on leased communication circuits shall be conducted at 24 month intervals, while intervals for testing power line carrier equipment shall be equipment specific.~~

10.3 VERIFICATION AND MAINTENANCE PRACTICES

~~10.3.1 The transmitter shall establish verification intervals for protection systems not otherwise covered by the requirements of a reliability organization. Verification is required after any change is made to an existing protection system. A transmitter shall use the maximum verification intervals established by reliability organizations and in accordance with applicable reliability standards: (a) four years for most 115kV elements, most transformer stations, and certain 230kV elements; (b) two years for all other high voltage elements. All newly commissioned protection systems shall be verified within six months of the initial in service date of the system.~~

~~10.3.2 Routine verification shall ensure with reasonable certainty that the protection systems respond correctly to fault conditions.~~

~~10.3.3 A transmitter shall use an electrically initiated simulated fault clearing check to verify new protection systems, after any wiring or component changes are made to an existing protection system, and for the routine verification of a protection system.~~

10.4 FUNCTIONAL TESTS AND PERIODIC VERIFICATION

10.4.1 For direct current circuitry checks, a transmitter shall thoroughly check the logic of the transmitter's auxiliary circuitry with the direct current applied and the initiating devices suitably energized to initiate the process. ~~When primary relays are the initiating device, the initiation shall be achieved by secondary injection of appropriate electrical quantities to the measuring elements. In cases where the sequence of operation is critical, monitoring by a portable sequence of events recorder may be required for proper analysis.~~ Operation or tripping of any interrupting or isolating device shall always be verified, as well as local and/or remote annunciation ~~and target operation.~~

10.5 FAILURE PROTECTION FOR HIGH VOLTAGE INTERRUPTING DEVICES

10.5.4 A transmitter shall not use automatic ground switches for any transmitter owned new installations for triggering line protection operation ~~following the failure of a HVID.~~

10.6 INSTRUMENT TRANSFORMERS

10.6.2 A transmitter shall ensure that current transformers are connected so that adjacent relay protection zones overlap and, where they do not overlap, shall ensure appropriate mitigation is provided.

10.7 BATTERY BANKS AND DIRECT CURRENT SUPPLY

- 10.7.1 The ~~transmitter customer~~ shall ensure that if either the battery charger fails or the AC supply source fails, the station battery bank shall have enough capacity to allow the station to operate for at least eight hours for a single battery system or at least six hours for each of the batteries in a two battery system.
- 10.7.2 ~~The transmitter shall ensure that~~ Critical DC supplies such as relay protection circuits and high voltage interrupters (HVIs) shall be monitored and alarmed.
~~annunciated such as relay protection circuits and high voltage interrupters (HVIs).~~
- 10.7.3 ~~The transmitter shall ensure that~~ For all generating facilities connected to the transmission system, have two separately protected (fuse/breaker) and monitored DC station battery systems are required unless the transmitter and IESO determine otherwise.
- 10.7.4 ~~The transmitter shall ensure that~~ For tapped transformer stations, have at least one protected (fuse/breaker) monitored DC station battery system. The transmitter may specify that is required unless two systems are specified by the Transmitter are required.

13 COMING INTO FORCE

- 13.0.1 This Code shall be in effect as of the date on which it is published in the *Ontario Gazette*, and as of that date replaces the Transmission System Code issued by the Board on August 26, 2013.

APPENDIX 1

VERSION A - FORM OF CONNECTION AGREEMENT FOR LOAD CUSTOMERS SCHEDULE E

GENERAL TECHNICAL REQUIREMENTS

1.1 Intentionally Left Blank ~~Guidelines of Reliability Organizations~~

~~1.1.1. Customers and Transmitters shall follow all reliability organizations' standards as they may be amended from time to time.~~

~~1.1.2. The Transmitter shall provide to Customers upon request, the address and contact persons at the relevant reliability organization.~~

1.3. Protection and Control

1.3.1. The protection systems, which protects transmission system elements, shall be capable of minimizing the severity and extent of disturbances to the transmission system while themselves experiencing a first-order single contingency such as the failure of a relay protection system to operate or the failure of a breaker to trip. In particular:

1.3.1.1. the elements designated by the Transmitter or the IESO as essential to system reliability and security shall be protected by two protection systems. Each system shall be independently capable of detecting and isolating all faults on those elements. These elements shall have breaker failure protection, but breaker failure protection need not be duplicated. Both protection systems shall initiate breaker failure protection;

1.3.1.3. the use of two identical protection systems should be avoided ~~is not generally recommended~~, because it increases the risk of simultaneous failure of both systems due to design deficiencies or equipment problems;

1.3.1.10. the two protection systems shall be supplied either from separate secondary windings of a voltage and current transformer or from separate voltage and current transformers; ~~on one voltage transformer or potential device and from separate current transformer secondary windings, i.e., from two separate current transformers;~~

1.8. Procedures for Maintenance and Periodic Verification

1.8.1. The Transmitter, using good utility practice, may specify the maintenance criteria and the maximum time intervals between verification cycles for those parts of Customers' ~~facilities~~ that may materially adversely affect the transmission system. The obligations

for maintenance and performance re-verification shall be stipulated in the appropriate schedule to this Connection Agreement.

SCHEDULE F
ADDITIONAL TECHNICAL REQUIREMENTS FOR TAPPED CONNECTIONS
TRANSFORMER STATIONS SUPPLYING LOAD:

- (a) Transmitter's Tapped Transformer Stations; and
- (b) ~~Distributor's and Consumer~~ Customer's Tapped Transformer Stations

1.1. Supply Considerations

- 1.1.4. Transmitter approval is required before grounding the neutral of power transformer windings at tapped transmission system stations. ~~The neutrals of the power transformer primary windings at transmission system tapped stations are normally not grounded. Transmitters shall approve grounded transformers by exception only.~~
- 1.1.5. Customers ~~Consumers and Distributors~~ shall participate in load shedding to meet reliability standards.
- 1.1.6. A transmission system breaker of a Customer ~~Consumer or Distributor~~ shall not autoreclose without Transmitter's approval.
- 1.1.7. A Customer ~~Consumer or a Distributor~~ shall not manually energize a Transmitter's line without the Transmitter's approval.

1.2. Protection Requirements

- 1.2.1. The typical technical requirements for Customer ~~Distributor and Consumer~~ protection shall be followed, as presented in Exhibit E.1 of Schedule E and Exhibits F.1 and F.2 of this Schedule F.

SCHEDULE G

PROTECTION SYSTEM REQUIREMENTS

1.1 Telecommunications

- 1.1.2 The Transmitter shall specify to the Customer the telecommunication channel media and protective systems. These requirements apply to the facilities that interface between the Customer and the Transmitter.
- 1.1.4. ~~Intentionally left blank. Where each of the dual protections protecting the same system element requires communication channels, the equipment and channel for each protection shall be separated physically and designed to minimize the risk that both protections might be disabled simultaneously by a single contingency.~~
- 1.1.6. Major disturbances caused by telecommunication failures shall have annual frequency of less than 0.002 per year from the dependability aspect and less than 0.002 per year from the security aspect or as otherwise prescribed by the Transmitter.
- 1.1.7. Telecommunication protection for a single transmission system circuit shall have an unavailability less than forty two (42) minutes per year, and for two circuits it shall be ~~less-~~ no more than four (4) minutes per year or as otherwise prescribed by the Transmitter.
- 1.1.8. The telecommunication false-trip rate used as part of a protection system for a single transmission system circuit shall be not more than 0.1 false trips per year, and for two circuits it shall be not more than 0.001 false trips per year unless otherwise prescribed by the Transmitter.
- 1.1.9. Total transmission system circuit trips coincident with telecommunications failure shall be not more than 0.001 per year unless otherwise prescribed by the Transmitter.

1.2 Test Schedule for Relaying Communication Channels

- 1.2.1. Communication channels associated with protective relaying shall be tested at periodic intervals in accordance with applicable reliability standards to verify that the channels are operational and that their characteristics ~~he~~ are within specific tolerances. Testing should include signal adequacy tests and channel performance tests. The Transmitter shall establish testing intervals for any communication channels not otherwise subject to reliability standards. The testing consists of signal adequacy tests and channel performance tests.

~~1.2.1.1. Signal adequacy test intervals are:~~

~~1.2.1.1.1. Channels for Protection (unmonitored) at one (1) month intervals; and~~

~~1.2.1.1.2. Channels for Protection (monitored) at twelve (12) month intervals.~~

~~1.2.1.2. Channel performance testing on leased communication circuits shall be conducted at 24 month intervals, while intervals for testing power line carrier equipment shall be equipment specific.~~

1.3. Verification and Maintenance Practices

- 1.3.1. Customers shall perform routine verifications of protection systems ~~on a scheduled basis~~ in accordance with applicable reliability standards. The Customer shall establish verification intervals for any protection systems not otherwise covered by the requirements of a reliability organization. The reverification period for those protections systems is to be entered in the agreement and initialed by the parties. A Customer shall re-verify after a change is made to an existing system. The maximum verification interval is four years for most 115 kV elements, most transformer stations, and certain 230 kV elements and two years for all other high voltage elements. All newly commissioned protection systems shall be verified within six months of the initial in-service date of the system.
- 1.3.2. ~~Intentionally left blank. Routine verification shall ensure with reasonable certainty that the protections respond correctly to fault conditions.~~
- 1.3.3. ~~Intentionally left blank. An electrically initiated simulated fault clearing check is mandatory to verify new protections, after any wiring or component changes are made to a protection, and for routine verification of a protection.~~
- 1.3.6. The Transmitter and the Customer shall consult on the functional test procedures. The tests shall not begin until the procedure is accepted by the Transmitter. If they cannot agree, the supply or continuity of supply shall depend on the performance of the tests that the Transmitter shall require. Transmitters and Customers shall agree upon the final functional test procedures before the tests begin. If they cannot agree, the supply or continuity of supply shall depend on the performance of the tests that the Transmitter shall require.
- 1.3.8. Customers shall make available to the Transmitter records of relay calibrations and protection verifications, so that records of the facility's performance can be maintained. The specific records required shall be identified in this Connection Agreement.

1.4. Functional Tests and Periodic Verification

1.4.3. For direct current (DC) circuitry checks, a Transmitter shall thoroughly check the logic of the Transmitter's auxiliary circuitry and the Customer shall thoroughly check the Customer's auxiliary circuitry shall be thoroughly checked with the DC applied and the initiating devices suitably energized to initiate the process. ~~When primary relays are the initiating device, the initiation shall be achieved by secondary injection of appropriate electrical quantities to the measuring elements. In certain cases where the sequence of operation is critical, monitoring by a portable sequence of events recorder may be required for proper analysis.~~ Operation or /tripping of all any interrupting or /isolating devices shall always be verified, as well as local and/or remote annunciation and target operation.

1.5. Failure Protection for High-Voltage Interrupting Devices (HVIs)

1.5.2. The HVI failure protection will initiate remote or transfer trip circuits and opening of the motor-operated disconnection switch unless otherwise prescribed by the Transmitter. ~~In general, the transmission system will require the HVI failure protection to be achieved by using remote or transfer trip circuits.~~

1.5.4. Automatic ground switches are not acceptable for any new installations for triggering line protection operation ~~following the failure of a HVI.~~

1.6. Instrument Transformers

1.6.2. Current transformers ~~shall~~ should be connected so that adjacent relay protection zones overlap. Where they do not overlap, the Transmitter may approve alternative mitigation at its discretion.

1.7. Battery Banks and Direct Current Supply

1.7.2. Critical DC supplies such as relay protection circuits and high voltage interrupters (HVIs) shall be monitored and alarmed. ~~annunciated such as relay protection circuits and high voltage interrupters (HVIs).~~

1.7.3. For all generating facilities connected to the transmission system, two separately protected (fuse/breaker) and monitored DC station battery systems are required unless the Transmitter and the IESO determine otherwise.

1.7.4. For tapped transformer stations, one protected (fuse/breaker) monitored DC station battery system is required unless two systems are specified by the Transmitter.

**APPENDIX 1
VERSION B - FORM OF CONNECTION AGREEMENT
FOR GENERATOR CUSTOMERS**

SCHEDULE E

GENERAL TECHNICAL REQUIREMENTS

1.1 Intentionally left blank. ~~Guidelines of Reliability Organizations~~

~~1.1.1. Customers and Transmitters shall follow all reliability organizations' standards as they may be amended from time to time.~~

~~1.1.2. The Transmitter shall provide to Customers upon request, the address and contact persons at the relevant reliability organization.~~

1.3. Protection and Control

1.3.1. The protection systems, which protects transmission system elements, shall be capable of minimizing the severity and extent of disturbances to the transmission system while themselves experiencing a first-order single contingency such as the failure of a relay protection system to operate or the failure of a breaker to trip. In particular:

1.3.1.1. the elements designated by the Transmitter or the IESO as essential to system reliability and security shall be protected by two protection systems. Each system shall be independently capable of detecting and isolating all faults on those elements. These elements shall have breaker failure protection, but breaker failure protection need not be duplicated. Both protection systems shall initiate breaker failure protection;

1.3.1.3. the use of two identical protection systems should be avoided ~~is not generally, recommended,~~ because it increases the risk of simultaneous failure of both systems due to design deficiencies or equipment problems;

1.3.1.10. the two protection systems shall be supplied from separate secondary windings of a one-voltage and current transformer or potential device and from separate voltage and current transformers secondary windings, i.e., from two separate current transformers;

1.8. Procedures for Maintenance and Periodic Verification

1.8.1. The Transmitter, using good utility practice, may specify the maintenance criteria and the maximum time intervals between verification cycles for those parts of Customers' facilities that may materially adversely affect the transmission system. The obligations for maintenance and performance re-verification shall be stipulated in the appropriate schedule to this Connection Agreement.

SCHEDULE F

ADDITIONAL TECHNICAL REQUIREMENTS

1.1 Supply Considerations

- 1.1.5 ~~Transmitter approval is required before grounding the neutral of power transformer windings at tapped transmission system stations. The method of grounding the neutral of all power transformer primary windings shall require the approval of the Transmitter. The Transmitter shall give its approval if it is satisfied that the reliability of its transmission system is not affected.~~

1.5 Autoreclosure and Manual Energization

- 1.5.2 Following a protection operation on a transmission line, the transmission breakers, located mainly in network switching and/or transformation stations, shall autoreclose after a certain time delay. Where the Generator is directly connected to the transmission line, or for configurations where the Generator could be damaged by autoreclosure of the line, the Generator shall provide a reliable means of disconnecting its equipment before autoreclosure. The Generator is responsible for protecting its own equipment and the Transmitter is not liable for damage to the Generator's equipment except as stipulated in section 15 of this Connection Agreement. The Generator may request a means of supervising the transmission autoreclosure prior to the disconnection of its equipment e.g. changes in protection logic at one or both stations to reduce the risk of such events. The criteria governing the use of reclosures are set out in the Ontario Hydro "Policies, Principles & Guidelines" document A"C-3.4.1(R1), Automatic Reclosure and Manual Energization on Bulk System Electricity Circuits", which was in effect as of April 1, 1999.

EXHIBIT F.2 TYPICAL GENERATOR-OWNED TRANSMISSION LINE PROTECTION REQUIREMENT

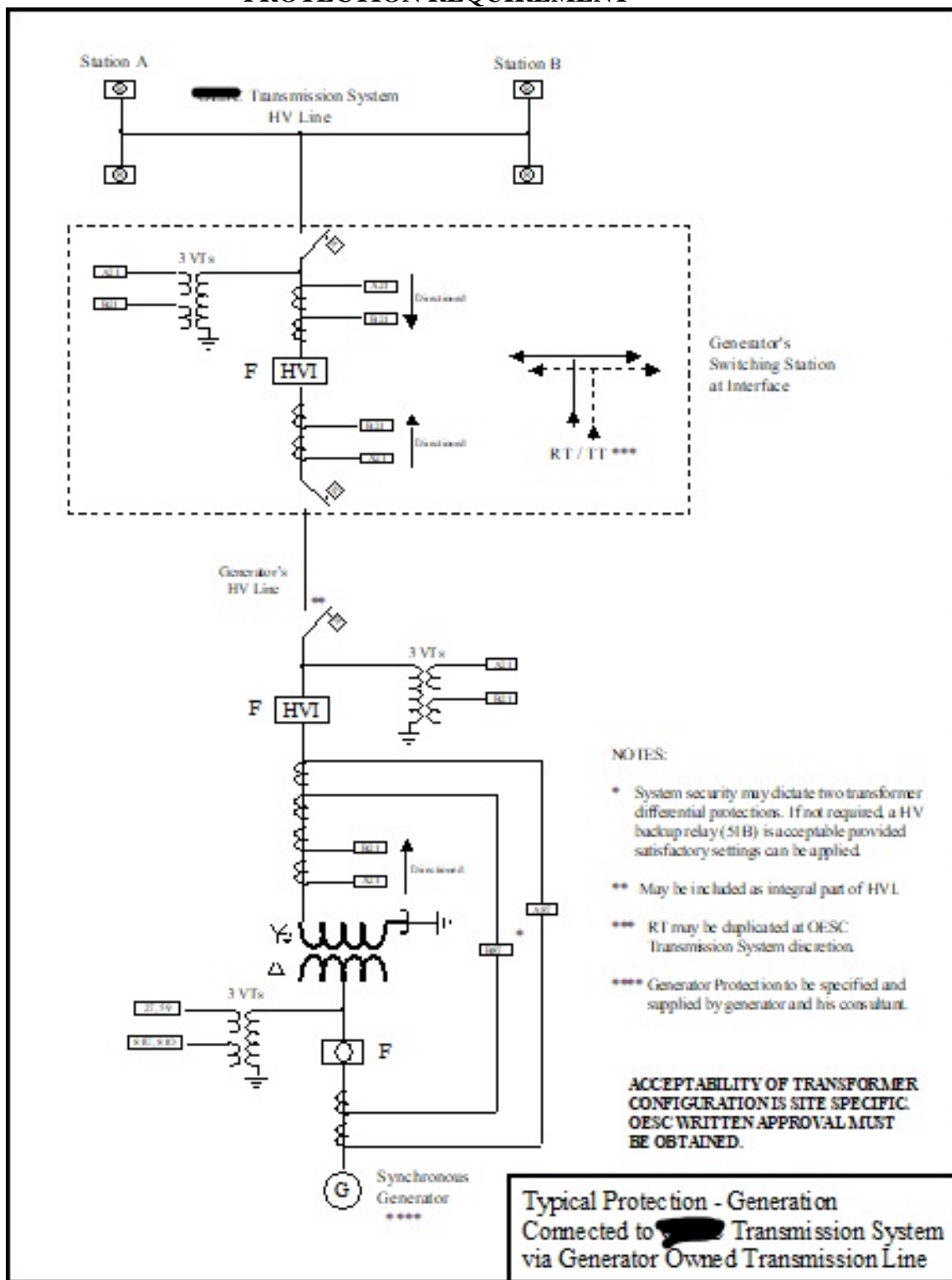

SCHEDULE G

PROTECTION SYSTEM REQUIREMENTS

1.1 Telecommunications

- 1.1.2. The Transmitter shall specify to all Customers the Transmitters shall specify telecommunication channel media and protective systems. These requirements apply to the facilities that interface between the Customer and the Transmitter.
- 1.1.4. Intentionally left blank. Where each of the dual protections protecting the same system element requires communication channels, the equipment and channel for each protection shall be separated physically and designed to minimize the risk that both protections might be disabled simultaneously by a single contingency.
- 1.1.6. Major disturbances caused by telecommunication failures shall have annual frequency of less than 0.002 per year from the dependability aspect and less than 0.002 per year from the security aspect or as otherwise prescribed by the Transmitter.
- 1.1.7. Telecommunication protection for a single transmission system circuit shall be unavailable for no more have an unavailability less than forty two (42) minutes per year, and for two circuits no more it shall be less than four (4) minutes per year or as otherwise prescribed by the Transmitter.
- 1.1.8. The telecommunication false-trip rate used as part of a protection system for a single transmission system circuit ~~shall be not~~ is no more than 0.1 false trips per year, and for two circuits it shall be not is no more than 0.001 false trips per year unless otherwise prescribed by the Transmitter.
- 1.1.9. Total transmission system circuit trips coincident with telecommunications failure ~~shall be not~~ are not more than 0.001 per year unless otherwise prescribed by the Transmitter.

1.2. Test Schedule for Relaying Communication Channels

- 1.2.1. Communication channels associated with protective relaying shall be tested at periodic intervals in accordance with applicable reliability standards to verify that the channels are operational and that their characteristics ~~lie~~ are within specific tolerances. Testing should include ~~The testing consists of~~ signal adequacy tests and channel performance tests. The Transmitter shall establish testing intervals for any communication channels not otherwise subject to reliability standards.

~~1.2.1.1. Signal adequacy test intervals are:~~

~~1.2.1.1.1. Channels for Protection (unmonitored) at one (1) month intervals; and~~

~~1.2.1.1.2. Channels for Protection (monitored) at twelve (12) month intervals.~~

~~1.2.1.2. Channel performance testing on leased communication circuits shall be conducted at 24 month intervals, while intervals for testing power line carrier equipment shall be equipment specific.~~

1.3. Verification and Maintenance Practices

- 1.3.1. Customers shall perform routine verifications of protection systems on a scheduled basis in accordance with applicable reliability standards. The Customer shall establish verification intervals for any protection systems not otherwise covered by the requirements of a reliability organization. The reverification period for those protection systems is to be entered in the agreement and initialed by the parties. The Customer shall re-verify after a change is made to an existing protection system. The maximum verification interval is four years for most 115 kV elements, most transformer stations, and certain 230 kV elements and two years for all other high voltage elements. All newly commissioned protection systems shall be verified within six months of the initial in-service date of the system.
- 1.3.2. ~~Intentionally left blank. Routine verification shall ensure with reasonable certainty that the protections respond correctly to fault conditions.~~
- 1.3.3. ~~Intentionally left blank. An electrically initiated simulated fault clearing check is mandatory to verify new protections, after any wiring or component changes are made to a protection, and for routine verification of a protection.~~
- 1.3.6. The Transmitters and the Customers shall consult on the ~~agree upon the final~~ functional test procedures ~~before the tests begin~~. The tests shall not begin until the procedure is accepted by the Transmitter. If they cannot agree, the supply or continuity of supply shall depend on the performance of the tests that the Transmitter shall require.

1.4. Functional Tests and Periodic Verification

- 1.4.1. Upon verification that the Customer's static tests on protection and control equipment, outlined in the Code and this Connection Agreement have been satisfactorily completed, a series of tests shall be performed with the equipment in a dynamic mode. These tests shall ensure that the equipment performs correctly when it should and also that it will not operate improperly.

1.4.3. For direct current (DC) circuitry checks, the Transmitter shall thoroughly check the logic of the Transmitter's auxiliary circuitry and the Customer shall thoroughly check the Customer's auxiliary circuitry ~~shall be thoroughly checked~~ with the DC applied and the initiating devices suitably energized to initiate the process. ~~When primary relays are the initiating device, the initiation shall be achieved by secondary injection of appropriate electrical quantities to the measuring elements. In certain cases where the sequence of operation is critical, monitoring by a portable sequence of events recorder may be required for proper analysis.~~ Operation or ~~tripping~~ of ~~all~~ any ~~interrupting or~~ isolating devices shall always be verified, as well as local and/or remote ~~annunciation and target operation~~.

1.5. Failure Protection for High-Voltage Interrupting Devices (HVIs)

1.5.2. The HVI failure protection will initiate remote or transfer trip circuits and opening of the motor-operated disconnection switch unless otherwise prescribed by the Transmitter. ~~In general, the transmission system will require the HVI failure protection to be achieved by using remote or transfer trip circuits.~~

1.5.4. Automatic ground switches are not acceptable for any new installations for triggering line protection operation ~~following the failure of a HVI.~~

1.6. Instrument Transformers

1.6.2. Current transformers ~~shall~~ should be connected so that adjacent relay protection zones overlap. Where they do not overlap, the Transmitter may approve alternative mitigation at its discretion.

1.7. Battery Banks and Direct Current Supply

1.7.2. Critical DC supplies such as relay protection circuits and high voltage interrupters (HVIs) shall be monitored and alarmed. ~~annunciated such as relay protection circuits and high voltage interrupters (HVIs).~~

1.7.3. For all generating facilities connected to the transmission system, two separately protected (fuse/breaker) and monitored DC station battery systems are required unless the Transmitter and the IESO determine otherwise.

1.7.4. For tapped transformer stations, one protected (fuse/breaker) monitored DC station battery system is required unless two systems are specified by the Transmitter.