

Hydro One Networks Inc.

483 Bay Street
7th Floor South Tower
Toronto, Ontario M5G 2P5
HydroOne.com

Joanne Richardson

Director, Major Projects and
Partnerships

☎ 416.902.4326

Joanne.Richardson@HydroOne.com

BY EMAIL AND RESS

September 5, 2023

Ms. Nancy Marconi
Registrar
Ontario Energy Board
Suite 2700, 2300 Yonge Street
P.O. Box 2319
Toronto, ON M4P 1E4

Dear Ms. Marconi,

EB-2023-0199 – Hydro One Networks Inc. – Leave to Construct Application – Etobicoke Greenway Project – Application and Evidence

Pursuant to s.92 of the *Ontario Energy Board Act, 1998* (the “Act”) Hydro One Networks Inc. (“HONI”) seeks the Ontario Energy Board’s (“OEB”) approval for an Order or Orders granting leave to construct approximately 6.5 km of 230 kV transmission line facilities (“**RxM Project**” or “**Etobicoke Greenway Project**” or “**Project**”), between Richview Transmission Station and Manby Transmission Station in the Southwest GTA.

Hydro One is confirming that the documents filed in support of the referenced application do not include any personal information under the Freedom of Information and Protection of Privacy Act (Ontario) (“FIPPA”) with respect to this Application. Any FIPPA related information in the Application has been redacted.

An electronic copy of this Application and Evidence has been filed through the OEB’s Regulatory Electronic Submission System.

Sincerely,



Joanne Richardson

EXHIBIT LIST

<u>Exhibit</u>	<u>Tab</u>	<u>Schedule</u>	<u>Attachment</u>	<u>Contents</u>
<u>A</u>				
	1	1		Exhibit List
	1	2		Application Table of Concordance
	1	3		List of Acronyms and Abbreviations
<u>B</u>				
	1	1		Application
	2	1		Project Overview Documents
	2	1	1	General Area Map
	2	1	2	Schematic Diagram of Proposed Facilities
	3	1		Evidence In Support of Need
	3	1	1	IESO Evidence in Support of Need
	4	1		Project Categorization and Classification
	5	1		Cost Benefit Analysis and Options
	6	1		Quantitative and Qualitative Benefits of the Project
	7	1		Apportioning Project Costs and Risks
	8	1		Connection Projects Requiring Network Reinforcement
	9	1		Transmission Rate Impact Assessment
	10	1		Revenue Requirement Information and Deferral Account Requests
	10	1	1	Investment Summary Document: T-SS-06 Southwest GTA Transmission Reinforcement

<u>Exhibit</u>	<u>Tab</u>	<u>Schedule</u>	<u>Attachment</u>	<u>Contents</u>
	11	1		Project Schedule
<u>C</u>				
	1	1		Descriptions of the Physical Design
<u>D</u>				
	1	1		Operational Details
<u>E</u>				
	1	1		Land Matters
	1	1	1	Routing Maps
<u>F</u>				
	1	1		System Impact Assessment
	1	1	1	IESO System Impact Assessment
<u>G</u>				
	1	1		Customer Impact Assessment
	1	1	1	Final Customer Impact Assessment
<u>H</u>				
	1	1		Regional and Bulk Planning
	1	1	1	Toronto Integrated Regional Resource Plan Addendum: Richview x Manby 230 kV Circuit Upgrade
	1	1	2	Toronto Region: Integrated Regional Resource Plan
	1	1	3	Toronto Regional Infrastructure Plan

APPLICATION TABLE OF CONCORDANCE

1

2

Exhibit	Content	FR Section	Hydro One S.92 Application Section
A	The Index	4.3.1	A-01-01 – Exhibit List
			A-01-02 – Application Table of Concordance
B	The Application	4.3.2	
	Administrative Matters	4.3.2.1	B-01-01 – Application
	Project Overview	4.3.2.2	B-02-01 – Project Overview Documents C-01-01 – Descriptions of the Physical Design
	Evidence in Support of Need for the Project	4.3.2.3	B-03-01 – Evidence in Support of Need
	Project Categorization	4.3.2.4	B-04-01 – Project Categorization and Classification
	Analysis of Alternatives	4.3.2.5	B-05-01 – Cost Benefit Analysis and Options B-06-01 – Quantitative and Qualitative Benefits of the Project H-01-01 – Regional and Bulk Planning
	Project Costs	4.3.2.6	B-07-01 – Apportioning Project Costs and Risks B-09-01 – Transmission Rate Impact Assessment
	Risks	4.3.2.7	B-07-01 – Apportioning Project Costs and Risks
	Comparable Projects	4.3.2.8	B-07-01 – Apportioning Project Costs and Risks
	Connection Projects that Also Address a Network Need	4.3.2.9	B-08-01 – Connection Projects Requiring Network Reinforcement
	Connection Projects Requiring Network Reinforcement	4.3.2.10	B-08-01 – Connection Projects Requiring Network Reinforcement
	Transmission Rate Impact Assessment	4.3.2.11	B-09-01 – Transmission Rate Impact Assessment
	Establishment of Deferral Accounts	4.3.2.12	B-10-01 – Revenue Requirement Information and Deferral Account Requests
	Capital Contribution Period	4.3.2.13	B-09-01 – Transmission Rate Impact Assessment
	Project Schedule	4.3.2.14	B-11-01 – Project Schedule
C	Project Details	4.3.3	
	The Route	4.3.3.1	B-02-01 – Project Overview Documents
	Description of the Physical Design	4.3.3.2	C-01-01 – Descriptions of the Physical Design
	Maps	4.3.3.3	E-01-01 – Land Matters

Exhibit	Content	FR Section	Hydro One S.92 Application Section
D	Design Specification and Operational Data	4.3.4	
	Operational Details	4.3.4.1	D-01-01 – Operational Details
E	Land Matters	4.3.5	
	Description of Land Rights Required	4.3.5.1	E-01-01 – Land Matters
	Land Acquisition Process	4.3.5.2	E-01-01 – Land Matters
	Land-related Forms	4.3.5.3	E-01-01 – Land Matters
	Early Access to Land	4.3.5.4	E-01-01 – Land Matters
F	System Impact Assessment	4.3.6	F-01-01 – System Impact Assessment
G	Customer Impact Assessment	4.3.7	G-01-01 – Customer Impact Assessment
H	Regional and Bulk Planning	4.3.8	
	Integrated Regional Resource Plan	4.3.8.1	H-01-01 – Regional and Bulk Planning
	Regional Infrastructure Plan	4.3.8.2	H-01-01 – Regional and Bulk Planning
	Bulk System Plan	4.3.8.3	N/A

LIST OF ACRONYMS AND ABBREVIATIONS

1

2

<u>Acronym or Abbreviation</u>	<u>Acronym or Abbreviation Expansion</u>
A	Amperes
AACE	Association for the Advancement of Cost Engineering (<i>estimate classification system</i>)
ACSR	Aluminium-Conductor Steel-Reinforced cable
ACSR/TW	Aluminium-Conductor Steel-Reinforced, trapezoidal shaped cable
AFUDC	Allowance for Funds Used During Construction
CIA	Customer Impact Assessment
Class EA	Class Environmental Assessment
EA	Environmental Assessment
ESR	Environmental Study Report
GTA	Greater Toronto Area
HOEP	Hourly Ontario Energy Price
Hydro One	Hydro One Networks Inc.
IESO	Independent Electricity System Operator
IRRP	Integrated Regional Resource Plan
ISD	Investment Summary Document
ISOC	Integrated System Operating Center
JCT	Junction
kcmil	Kilo-circular mils (<i>unit of measure of the area of a wire with a circular cross section</i>)
km	Kilometer
kV	Kilovolt
LTE	Long Term Emergency rating
MECP	Ministry of the Environment, Conservation and Parks
MTO	Ministry of Transportation
MTS	Municipal Transformer Station
MW	Megawatt
MWH (<i>or MWHR</i>)	Megawatt-hour
NERC	North American Electric Reliability Corporation
NPCC	Northeast Power Coordinating Council
NPV	Net Present Value
OEB	Ontario Energy Board
OM&A	Operations, Maintenance and Administrative costs
ORTAC	Ontario Resource and Transmission Assessment Criteria
PV	Present Value
RxM	Richview TS to Manby TS
RIP	Regional Infrastructure Plan
ROW	Right-of-Way

**Acronym or
Abbreviation**

Acronym or Abbreviation Expansion

RPP	Regulated Price Plan
SIA	System Impact Assessment
TS	Transformer Station
TSC	Transmission System Code
TSP	Transmission System Plan
UTR	Uniform Transmission Rates

- 1 4. An overview map of this area is provided in **Exhibit B, Tab 2, Schedule 1,**
2 **Attachment 1** and a schematic diagram of the proposed Project can be found at
3 **Exhibit B, Tab 2, Schedule 1, Attachment 2.**
4
- 5 5. The existing transmission corridor will provide sufficient width for the proposed
6 Project. As a result, no new permanent land rights on properties from Richview
7 TS to Manby TS will be required to accommodate the proposed transmission
8 facilities. Further information regarding the real estate needs to complete this
9 Project are provided in **Exhibit E, Tab 1, Schedule 1.**
10
- 11 6. The Project is subject to the Class EA for Minor Transmission Facilities (Hydro
12 One, 2022), an approved planning process under the *Ontario Environmental*
13 *Assessment Act*. The Class EA was developed as a streamlined process to
14 ensure that routinely undertaken minor transmission projects that have a
15 predictable range of effects are planned and carried out in an environmentally
16 acceptable manner. Hydro One has undertaken that Class EA and the Statement
17 of Completion to the MECP was filed on June 5, 2023.
18
- 19 7. The next major approval to be secured for the Project is leave to construct. The
20 proposed in-service date for the Project is March 2026, assuming a construction
21 commencement date of February 2024 and an OEB approval of this Application
22 by February 2024. A project schedule is provided at **Exhibit B, Tab 11,**
23 **Schedule 1.**
24
- 25 8. The IESO has completed a SIA. The SIA concludes that the Project is expected
26 to have no material adverse impact on the reliability of the integrated power
27 system and recommends that a *Notification of Conditional Approval for*
28 *Connection* be issued. The IESO's SIA is provided as **Exhibit F, Tab 1,**
29 **Schedule 1, Attachment 1** of Hydro One's prefiled evidence.

- 1 9. Hydro One has completed a CIA in accordance with Hydro One's connection
2 procedures. The results confirm that the Project will not have any adverse effect
3 on the voltage in the area and the Project will improve the supply reliability to the
4 Southwest Toronto area. A copy of the CIA is provided as **Exhibit G, Tab 1,**
5 **Schedule 1, Attachment 1.** Hydro One will fulfill all requirements of the SIA and
6 the CIA, and will obtain all necessary approvals, permits, licences, certificates,
7 agreements and rights required to construct the Project.
8
- 9 10. The forecast total capital cost of the Project transmission facilities is
10 \$73.1million¹. Details pertaining to these costs are provided at **Exhibit B, Tab 7,**
11 **Schedule 1.**
12
- 13 11. The Project will supply forecast incremental load growth of 334MW in the
14 western half of City of Toronto, southern Mississauga and Oakville areas.
15 Consequently, the expected rate impact associated with the Project (using 2023
16 OEB-approved uniform transmission rates as filed in **Exhibit B, Tab 9,**
17 **Schedule 1**) is a \$0.05/kw/month decrease in the network pool rate and a 0.06%
18 decrease on the overall average Ontario residential consumer's electricity bill.
19
- 20 12. The Application is supported by written evidence which includes details of the
21 Applicant's proposal for the transmission line. The written evidence is prefiled
22 and may be amended from time to time prior to the Board's final decision on this
23 Application.
24
- 25 13. Given the information provided in the prefiled evidence, Hydro One submits that
26 the Project is in the public interest. The Project meets the need of the
27 transmission system, improves quality of service and reliability and reduces the
28 price paid by ratepayers.

¹ There will be an additional \$1.762 million of OM&A removal costs associated with constructing this project.

1 14. Hydro One is consenting that this proceeding be disposed of without a hearing
2 pursuant to section 21(4) of the OEB Act. As is documented in the CIA there are
3 no directly connected customers that are adversely affected by this Project. The
4 Project concords with the commitments undertaken through the Class EA
5 process and the Statement of Completion to the MECP has been filed. The IESO
6 SIA confirms that the Project will have no material adverse impact on the
7 reliability of the integrated power system. The Project reduces transmission line
8 losses in a cost-effective manner and requires no new property rights to
9 complete. The Project addresses the reliability and capacity needs of the
10 transmission system and forecasts to reduce the network pool rate and the
11 overall average Ontario consumer's electricity bill. Given all of the above, Hydro
12 One concludes that this Project will not adversely affect customers in any
13 material way.

14
15 15. Hydro One requests that a copy of all documents filed with the Board be served
16 on the Applicant and the Applicant's counsel, as follows:

17
18 **a) The Applicant:**

19 Carla Molina
20 Sr. Regulatory Coordinator
21 Hydro One Networks Inc.

22
23 Mailing Address:
24 7th Floor, South Tower
25 483 Bay Street
26 Toronto, Ontario M5G 2P5

27 Telephone: (416) 345-5317

28 Fax: (416) 345-5866

29 Electronic access: regulatory@HydroOne.com

This page has been left blank intentionally.

PROJECT OVERVIEW DOCUMENTS

Hydro One is seeking approval to construct and operate transmission facilities between Richview TS and Manby TS. The Project will reinforce the transmission system on the Southwest GTA 230 kV transmission corridor by rebuilding the existing idle 115 kV double-circuit transmission line from Richview TS to Manby TS as a new 230 kV double-circuit transmission line within the existing corridor. The Project also includes modifying and reconfiguring the existing circuits R1K, R2K, R13K and R15K between Manby TS and Richview TS to incorporate the new line. Initially, the new line, as well as one of the existing lines, will be reconfigured to create two “super circuits”, which will allow for the two additional circuits to supply Manby TS and avoid the need to build new terminations. The following proposed facilities are subject to section 92 approval:

- Approximately 6.5 km span (or approximately 21 km of circuit length) of 230 kV double-circuit transmission line from Richview TS to Manby TS, on the existing corridor, including work required at Applewood JCT as per the SIA;
- Terminal station telecommunication modifications at Richview TS and Manby TS.

A map indicating the geographic location of the existing idle facilities as well as schematic diagrams of the proposed facilities are provided in **Exhibit B, Tab 2, Schedule 1, Attachment 1** and **Exhibit B, Tab 2, Schedule 1, Attachment 2**, respectively.

The transmission system in the area requires reinforcement due to increases in forecast load growth in the Southwest GTA arising from rapidly growing electricity demands of homes, businesses, and public transit initiatives.

Leave to construct approval sought in this Application is for Phase 1 of a two-phase project. Phase 2, which is not currently planned to be required until after 2030, will be coordinated with the proposed future Manby TS end of life refurbishment project. At that time, the two new super circuits will be separately terminated on the Manby 230 kV bus.

1 At Richview TS, they will connect to existing 230 kV circuits between Claireville TS and
2 Richview TS, thereby unbundling the two super circuits.

3
4 Further information on the Phase 1 overhead transmission line and the station facilities
5 is provided below.

6 7 **OVERHEAD TRANSMISSION LINE**

8 The total length of the corridor between Richview TS to Manby TS is approximately
9 6.5 km. There are currently four operating circuits from Richview TS to Manby TS. The
10 circuits are R1K, R2K, R13K, R15K. Between Richview TS and Manby TS there are also
11 two idle circuits which will be replaced through the completion of this Project. Those idle
12 circuits are referred to as K9S and K10SB and are situated on the east side of the
13 corridor.

14
15 The new 230 kV double-circuit transmission line will have its conductors paralleled to
16 become the new super circuit R15K and connected to the existing R15K termination at
17 Richview TS and Manby TS. The existing R15K on the R13K/R15K towerline will be
18 redesignated as R1K and connected to the existing R1K termination at Richview TS and
19 Manby TS. The two circuits on the existing R1K/R2K towerline will be paralleled to
20 become super circuit R2K and connected to the existing R2K termination at Richview TS
21 and Manby TS. In addition, Horner TS will be re-tapped to R15K, from R13K. As
22 provided before, to supplement this description, a diagram can be found in **Exhibit B,**
23 **Tab 2, Schedule 1, Attachment 2.**

24
25 With respect to the idle 115 kV transmission line, the existing conductor will be removed
26 and restrung on temporary poles¹. Subsequently, the old structures will be dismantled
27 and removed. New structures will be erected, and the existing conductor will be used to
28 string the new conductor on the new structures. To mitigate grounding risks along the

¹ The temporary poles will be situated within the existing corridor. Poles will be on the east side of the idle line, within the corridor.

1 corridor, new towers will be bonded to the adjacent towers of the existing 230 kV circuits
2 on the west side of the corridor and a total of three shield wires will be installed on the
3 new towers. New and modified line structures within each station property to
4 accommodate the termination of the new 230 kV super circuits will also be undertaken
5 as part of this Project. This will include building new circuit tapping structures and
6 counterpoising them. Conductor will be strung on the new tapping structures.

7

8 **RICHVIEW & MANBY TS TELECOMMUNICATION FACILITIES**

9 The Project will also deliver modifications to the telecommunication facilities at Richview
10 and Manby TS to provide status information and control capability to Hydro One's ISOC
11 and status information to the IESO.

This page has been left blank intentionally.

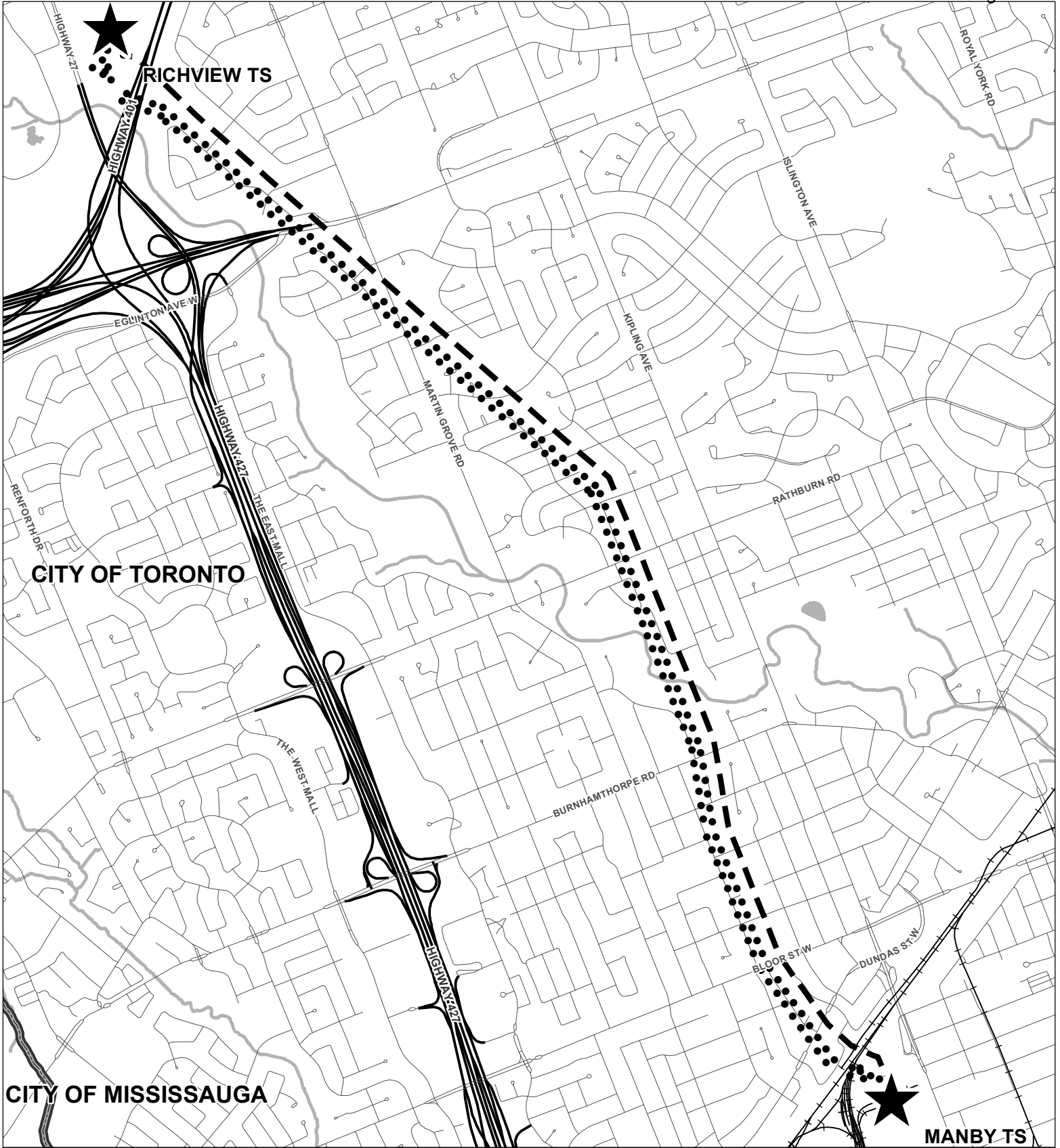

Map Legend

	Transformer Station		Railway		Watercourse		Existing 230 kV Transmission Lines
	Road		Waterbody		Proposed Project (Existing Idle Transmission Line)		
	Highway						

(C) Copyright Hydro One Networks Inc. All rights reserved. No part of this drawing may be redistributed or reproduced in any form by any photographic, electronic, mechanical or any other means, or used in any information storage or retrieval system. Neither Hydro One Networks Inc. nor any of its affiliates assumes liability for any errors or omissions.

Produced by Hydro One under Licence with the Ontario Ministry of Natural Resources © Queen's Printer for Ontario, 2023.

NOT TO BE REPRODUCED OR REDISTRIBUTED
 CONFIDENTIAL TO HYDRO ONE NETWORKS INC.
 Produced By: Hydro One Networks Inc., GIS Services /
 Date: Jul 14th, 2023 / Map23-057_V3

NTS

1
2

PROPOSED FACILITIES: RICHVIEW TS X MANBY TS 230 KV SCHEMATIC DIAGRAM

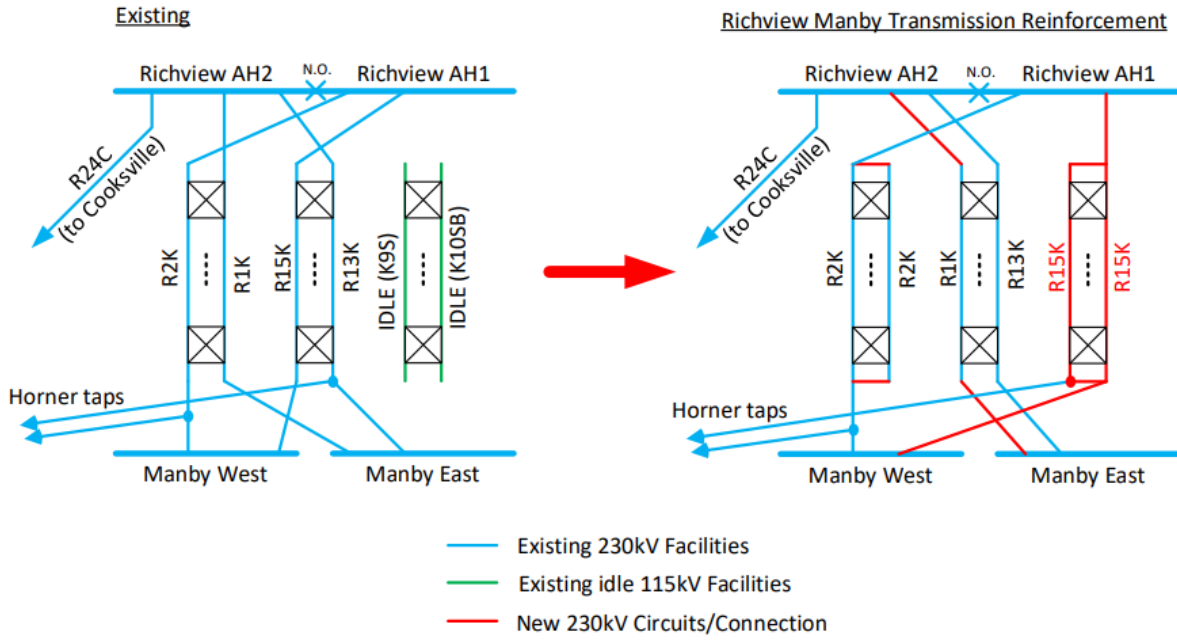

1 Not proceeding with this investment would result in Hydro One not meeting its obligation
2 and not addressing the need to provide adequate supply capacity to support load growth
3 and maintain system reliability in the Southwest GTA.

4

5 The 2021 IESO IRRP Addendum was predicated on a project estimate that was based
6 on a preliminary scope definition for the Project and predates the commencement of the
7 Class EA. Consequently, for the purposes of this Application, the IESO has
8 supplemented this need evidence with **Attachment 1 of this Schedule** that reaffirms
9 the need for the Project based on the estimate and scope that has been defined in this
10 Application.

Richview TS to Manby TS Transmission Corridor Upgrade: Need, Alternatives and Regional Planning Context

Final

August 2023

Table of Contents

1. Introduction	2
1.1. Executive Summary	2
2. Overview and Context: Toronto Regional Planning	5
2.1. Overview of the Richview South Area	5
2.2. 2015 Toronto Regional Plan	6
2.3. 2017 Addendum to the 2015 Toronto Regional Plan	6
2.4. 2019 Toronto Regional Plan	7
2.5. 2021 Addendum to the 2019 Toronto Regional Plan	7
2.6. Third Cycle of Toronto Regional Planning	8
3. Richview South System Need and Alternatives Analysis	9
3.1. Richview South Electricity Demand	9
3.2. Richview South Electricity System Need	10
3.3. Assessment of Alternatives	11
3.3.1. Gas Generation	11
3.3.2. Conservation and Demand Management	12
3.3.3. Battery Storage	12
3.3.4. Richview to Manby Transmission Upgrade – the Project	12
3.4. Updated Economic Analysis of Alternatives	13
4. Conclusion and Recommended Solution	14

1. Introduction

The IESO is providing this report in accordance with the requirements of the Ontario Energy Board's (OEB) Chapter 4 of the Filing Requirements for Electricity Transmission Applications, in respect of the transmission upgrade project (the "Project") described in Hydro One Networks Inc. ("HONI")'s Leave to Construct application for the 'Etobicoke Greenway Project' (the "Application").

This report provides an overview of the identified supply capacity need on the Richview Transformer Station ("TS") to Manby TS transmission corridor. The report summarizes the alternatives assessed, and recommendations made to meet the identified need, as part of Toronto regional planning activities, augmented with most recent available information. A summary of regional planning findings from past cycles is also provided as context.

This report concludes that the IESO continues to recommend that HONI proceed with the Project, which involves the rebuilding of an idle transmission line, as soon as possible. The main bases for this recommendation, as further described below, are that:

- the Project remains the most cost-effective option to address the identified need;
- the Project is capable of meeting forecasted demand up to 2040;
- no interim investment is required to meet the identified need before the in-service date of the Project;
- the Project, which involves the rebuilding of an idle line, will help strengthen the supply to the area and provide a basis for future expansion and growth; and
- if the Project does not proceed, and the capacity need is not addressed, there is a risk to customer reliability that will increase as demand grows.

1.1. Executive Summary

The Richview TS to Manby TS ("Richview to Manby") transmission corridor consists of two active 230 kV double-circuit lines (carrying circuits R1K, R2K, R13K, and R15K) and an idle 115 kV double-circuit line. These lines are owned and operated by HONI. This transmission corridor, along with another 230 kV circuit named R24C that extends between Richview TS and Cooksville TS, provides power to an area referred to as "Richview South". This area is defined electrically as being supplied by the Richview to Manby transmission corridor, and roughly comprises the western half of central and downtown Toronto—from the financial district to the east, Lawrence Avenue to the north, and Etobicoke to the west—and portions of southern Mississauga and Oakville. [Figure 1](#) provides a map indicating the Richview to Manby transmission corridor and an approximate boundary of the Richview South area.

The Project involves rebuilding of the idle 115 kV double-circuit line on the Richview to Manby transmission corridor to a 230 kV standard and operating it at 230 kV. The Project was recommended by the IESO as part of Toronto regional planning to address a supply capacity need identified in the Richview South area.

This Project was first identified in the first Integrated Regional Resource Plan (“IRRP”) for Toronto in 2015 (“2015 Toronto IRRP”) as a longer-term solution to meet forecast supply capacity needs. Since this first cycle of regional planning, all subsequent regional plans for the Toronto region, and most recently an Addendum Study prepared in 2021, have shown that the supply capacity need has become firm and that the recommended Project is the most cost-effective means of addressing this need.

Figure 1 | Area Supplied by the Richview to Manby Corridor

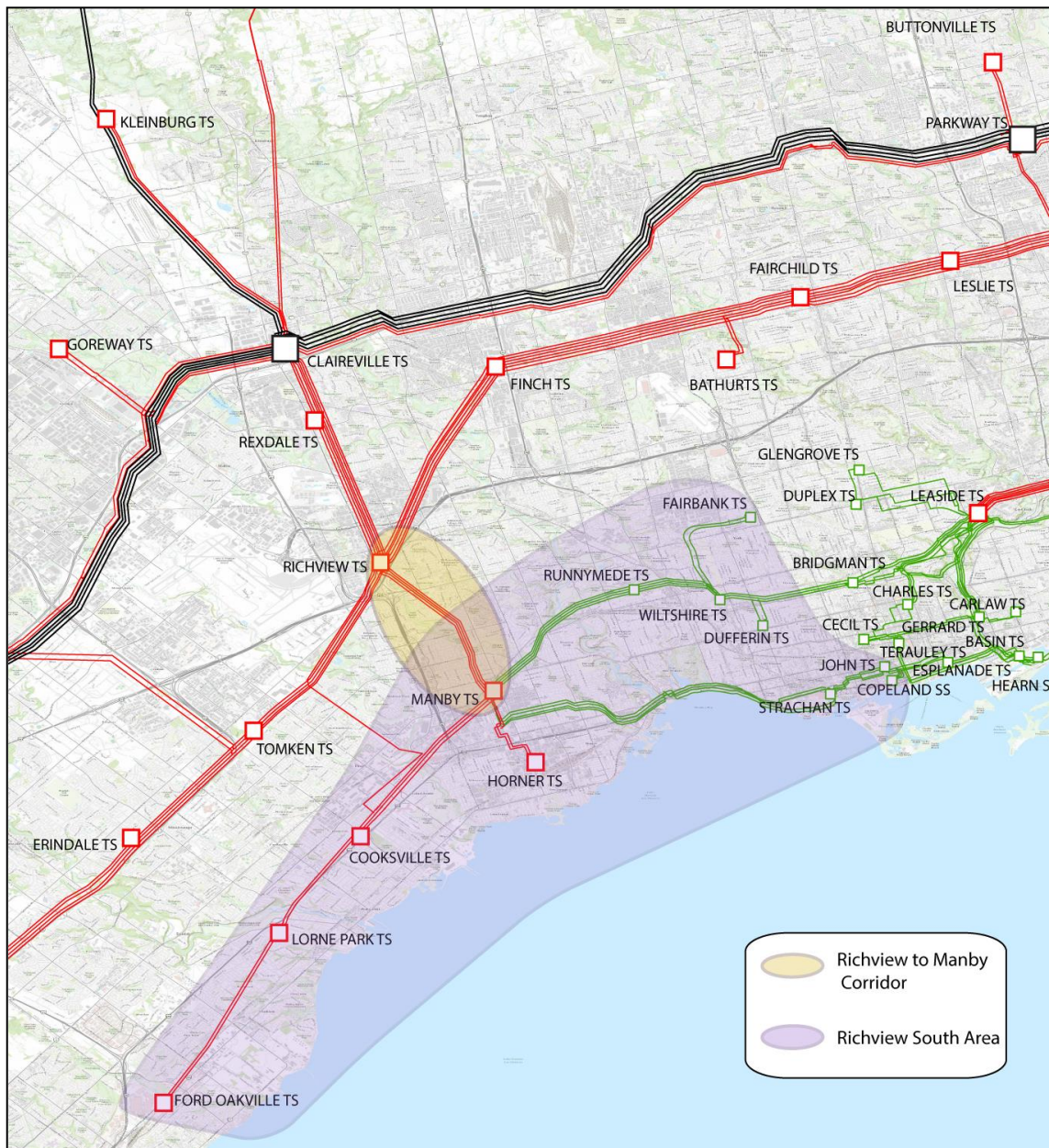

Since the publication of the 2021 Toronto Addendum new information and data has become available that affect the IESO's planning assumptions. Specifically, HONI has provided the IESO with the most recent cost of the Project, thus the IESO has updated the economic assessment of the alternatives. The IESO has updated its assessment and presented the results in this report. This updated assessment confirms that the Project remains the most cost-effective option to address the identified supply capacity need while maintaining system reliability. The assessment also confirms that the need is firm and growing. Therefore, the IESO continues to recommend that HONI proceed with the Project as soon as possible.

2. Overview and Context: Toronto Regional Planning

2.1. Overview of the Richview South Area

The Richview South area is defined electrically as being supplied by the Richview to Manby transmission corridor (R1K, R2K, R13K, and R15K) along with another 230 kV circuit, R24C, which runs along a separate corridor from Richview TS to Cooksville TS. These circuits are identified in [Figure 2](#).

Figure 2 | Single Line Diagram of Richview South Area

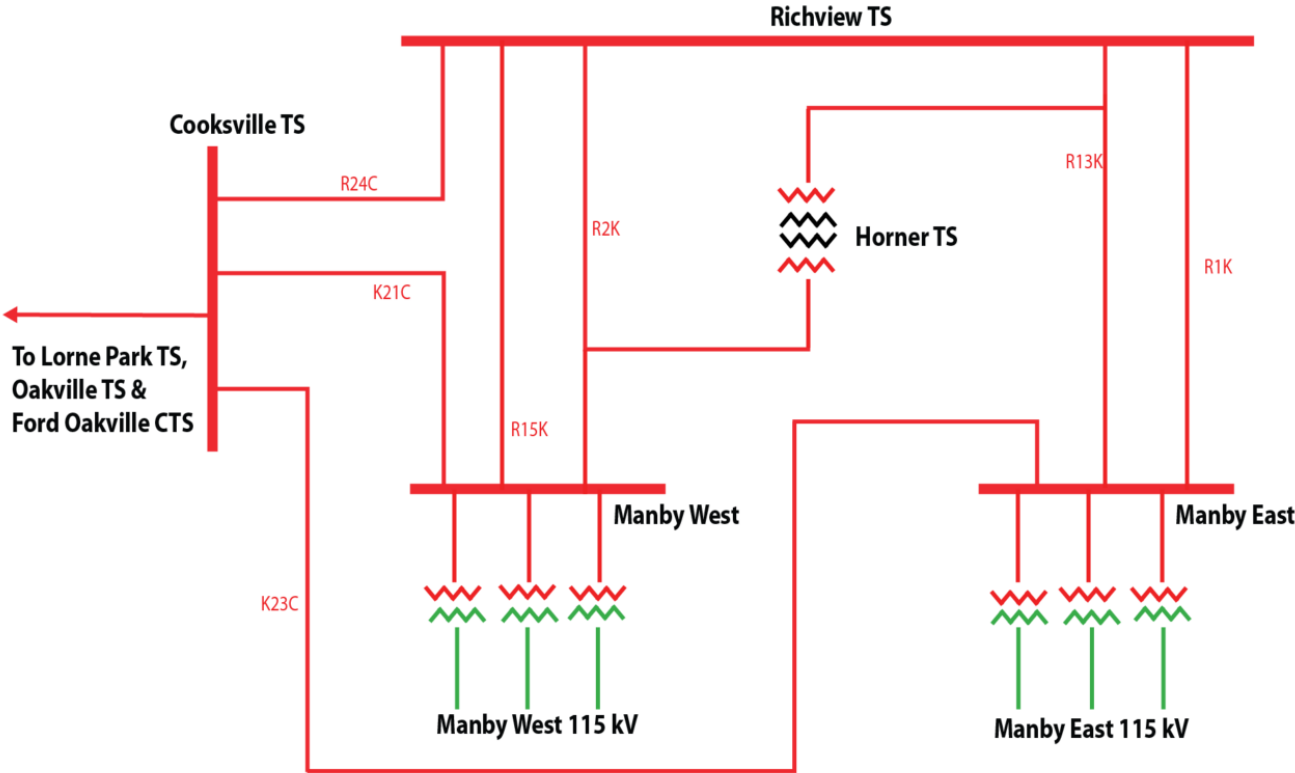

The Richview South area includes the western half of central and downtown Toronto—from the financial district in the east, Lawrence Avenue to the north, and Etobicoke to the west—which is supplied by a 115 kV system emanating from Manby TS.

The Richview South area also includes portions of southern Mississauga and Oakville that are supplied from Cooksville TS, Lorne Park TS, Oakville TS and Ford Oakville CTS. Most of the area consists of residential and commercial customers, with a few industrial customers connected to the area's transmission and distribution systems. As there is no local transmission-connected generation within the Richview South area, the Richview to Manby corridor is effectively the only supply to this area¹.

The Toronto 115 kV system has been built with various options to transfer loads between the Leaside and Manby 115 kV systems to enable better operational flexibility to accommodate planned outages, and to enable system restoration post-contingency. One such control action is transferring Dufferin TS (normally supplied by the Leaside TS 115 kV system) to Manby East 115 kV supply.

2.2. 2015 Toronto Regional Plan

The 2015 Toronto IRRP forecasted that a supply capacity need in the Richview South area would emerge between 2018 and 2021, depending on the rate of demand growth, and identified the Project as the recommended long-term solution to address this need. At the time, a conservation potential study had identified sufficient incremental demand response potential and distributed generation ("DG") in the area supplied by Manby TS to defer the need for the Project. Therefore, the 2015 Toronto IRRP recommended that these non-wires alternatives be acquired while concurrently asking HONI to complete detailed engineering design and specification for the Project.

2.3. 2017 Addendum to the 2015 Toronto Regional Plan

Following the publication of the 2015 Toronto IRRP, Metrolinx introduced plans to electrify the Lakeshore West GO train line. This would require a new traction power substation near Manby TS to provide power to the newly electrified trains. At the time, Metrolinx identified an initial in-service date of 2020 with a peak demand of 45 MW to 90 MW. This substantially exceeded the level of achievable conservation and DG potential that had been identified in the area. As the non-wires options (conservation and DG) were no longer technically feasible of meeting the need, an addendum to the regional plan was published in February 2017. This addendum recommended that HONI proceed with developing the Project to ensure adequate supply capacity to the Richview South area once Metrolinx's transit electrification project was in-service.

¹ There is approximately 23 MW of distribution-connected generation in the Richview South area that the IESO is aware of. Most of this generation consists of renewables with FIT and micro FIT contracts.

2.4. 2019 Toronto Regional Plan

At the time of the 2019 Toronto IRRP's publication, Metrolinx had delayed the in-service date of the traction power substation to the mid-2020s. However, a new demand forecast identified that the load meeting capability of the area would be reached by 2021 due to: (a) projected LDC load growth; and (b) the observation that the use of the control action to transfer Dufferin TS from its normal supply from the Leaside TS 115 kV system to the Manby TS 115 kV system was being deployed more frequently during summer peak conditions.² Therefore, the plan recommended that HONI proceed with the Project as soon as possible.

2.5. 2021 Addendum to the 2019 Toronto Regional Plan

After the publication of the 2019 Toronto IRRP, changes in key planning assumptions necessitated re-studying the recommendation from the 2019 IRRP. These changes included an updated CDM Achievable Potential Study³, the launch of the 2021-2024 CDM Framework⁴, and updates to the demand forecast in the Richview South area. These changes were relevant as they impacted both the characteristics of the supply capacity need and the options available to meet this need.

This updated assessment was published in the 2021 Toronto Addendum Study. It confirmed that the supply capacity need would emerge in 2021; however, the magnitude of the need had increased compared to that forecasted in the 2019 IRRP. This was attributed to an increase in the LDC demand forecast for the area, reflecting increased customer connection requests for new residential and commercial development. In addition, the 2021 Addendum Study explicitly considered the impact on the Richview to Manby corridor of the more frequent transfers of Dufferin TS to the Manby TS 115 kV system that had been necessary in recent years.

Following a review of options, including consideration of non-wires alternatives such as incremental cost-effective CDM, storage, gas generation, demand response, as well as flexible AC transmission system ("FACTS") devices⁵, the recommendation for the Project to address the Richview South need was reaffirmed. The 2021 Addendum Study concluded that the Project remained the most cost-effective option to address the supply capacity need and maintain system reliability. Further, it established that the recommended Project would add enough capacity to meet forecasted demand up to 2040^{6,7}.

² This transfer places additional load on the Manby 115 kV system.

³ 2019 Conservation Achievable Potential Study. <https://www.ieso.ca/2019-conservation-achievable-potential-study>

⁴ 2021-2024 Conservation and Demand Management Framework. <https://ieso.ca/en/Sector-Participants/Energy-Efficiency/2021-2024-Conservation-and-Demand-Management-Framework>

⁵ FACTS devices are a broad category of electrical equipment which can be used to dynamically control voltages within the system, and influence how power flow is distributed across multiple circuits.

⁶ See Appendix D of 2021 Toronto Addendum. <https://www.ieso.ca/-/media/Files/IESO/Document-Library/regional-planning/Toronto/Toronto-2021-Addendum.ashx>

⁷ The Project will also support the City of Toronto's decarbonization and electrification plans. The impacts of these plans will be assessed in the ongoing third cycle of regional planning for Toronto.

2.6. Third Cycle of Toronto Regional Planning

The third cycle of regional planning is currently underway for Toronto. Although the IRRP forecast has not yet been finalized, early qualitative insights have been referenced as applicable in this report.

3. Richview South System Need and Alternatives Analysis

Since the publication of the 2021 Toronto Addendum Study, several new developments have occurred that have the potential to impact the need and alternatives, most notably an increase to the cost of the Project and early indications that electricity demand could grow faster than anticipated. Accordingly, the IESO has updated its assumptions and refreshed the economic analysis of the alternatives. This section describes this update.

3.1. Richview South Electricity Demand

[Figure 3](#) shows the summer peak demand forecast for the Richview South area,⁸ along with extreme weather adjusted historical electricity demand. The demand forecast has not been updated since the 2021 Toronto Addendum Study. The main driver of growth in this forecast, particularly in the near-term, is new connection requests for residential and commercial development. New information (described below) provides qualitative insights into potential drivers of additional growth in the Richview South area but is not reflected in the forecast as the information is preliminary.

In March 2023, the IESO kicked off the third cycle of the Toronto IRRP. While the IRRP forecast has not yet been finalized, the IESO understands that it will consider the City of Toronto's 2040 Net Zero Strategy and Toronto Hydro's Climate Action Plan, neither of which were considered in any previous regional plans. Based on initial discussions with Toronto Hydro, future long-term electricity demand growth is expected to be significantly different from historical load, owing to electrification of end uses previously supplied by fossil fuels. The City of Toronto has also shown strong support to de-carbonize the electricity system. The combination of the potential for high electrification rates and grid de-carbonization is expected to increase the demand forecast in the City of Toronto substantially compared to the forecast seen in [Figure 3](#).

Metrolinx is still pursuing its plans to electrify its GO train lines, including the Lakeshore West line. This will involve building a new traction power substation ("TPSS") in Mimico which will add a large new load in the Richview South area. The project initially had an in-service date of 2020 but this has since been delayed to at least 2025. Metrolinx has provided a preliminary update that indicates the TPSS could consume up to ~60 MW more than previously indicated (incremental to the forecast found in [Figure 3](#)) and that they expect to finalize their requirements by early 2024⁹. This greater than anticipated growth in the Richview South area highlights the need to expeditiously address the capacity need.

⁸ The Richview South area electricity demand is summer peaking.

⁹ Metrolinx is still finalizing the electricity requirements for the Mimico traction station, so at this time the IESO has not updated the forecast to include this new, preliminary information.

3.2. Richview South Electricity System Need

The 2021 Addendum identified that the most limiting contingency in the system supplying the Richview South area is the loss of circuit R15K, which causes thermal overloading (exceeding long-term emergency (“LTE”) ratings) of the R2K circuit. This represents a violation under Section 7.1 of the IESO’s Ontario Resource and Transmission Assessment Criteria (ORTAC) and the North

Figure 3 | Historical and Forecasted Summer Peak Demand for the Richview South

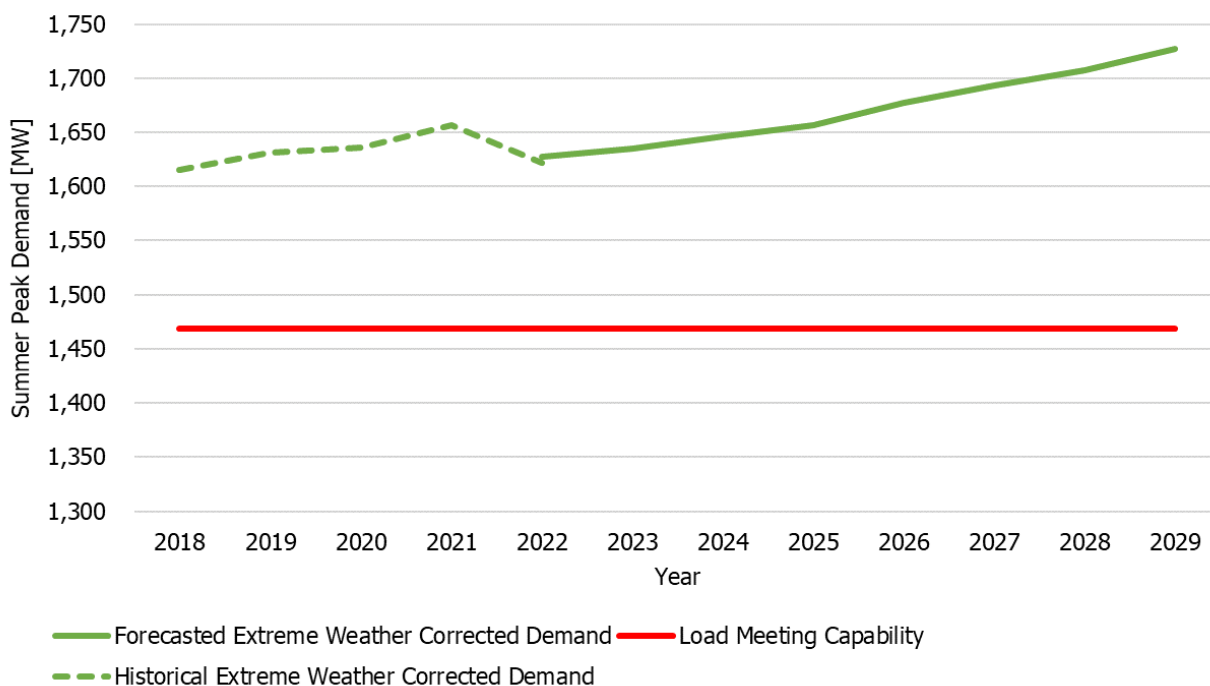

American Electric Reliability Corporation (NERC) TPL-001-5 planning standards. Based on this limiting contingency, the 2021 Addendum Study identified the load meeting capability (“LMC”) of the system supplying the Richview South area to be approximately 1,470 MW.

Figure 3 shows that the forecasted extreme-weather electricity demand in the Richview South area already exceeds the LMC of the area, based on planning criteria. This exceedance is expected to grow in the coming years. While actual weather conditions and operating measures such as revoking or recalling outages and reconfiguring the transmission system can mitigate the real-time impacts of a planning criteria exceedance, with further demand growth there will be a higher risk that more extreme control actions, such as voltage reductions or load shedding, could be required. These control actions are currently available to the control room operators and no interim investment is required to meet the forecasted need before the in-service date of the Project.

Further, Table 1 below shows that the actual historical load has been very close to, or exceeding, the area LMC in recent years. It is important to note that Dufferin TS load is included in the actual historical load for the Richview South system in recent years due to load transfers.

When corrected to reflect what the demand in each year would have been under extreme weather conditions, the historical demand would have been above the LMC. This indicates that the capacity need in the Richview South area exists today.

Table 1 | Historical Richview South Summer Peak Demand Compared to the Load Meeting Capability¹⁰

	2018	2019	2020	2021	2022
Actual Historical Load [MW]	1,463	1,391	1,479	1,439	1,418
Extreme Weather Corrected Historical Load [MW]	1,615	1,631	1,636	1,657	1,622

3.3. Assessment of Alternatives

The 2021 Toronto Addendum Study reviewed a number of alternatives, in addition to the Project, in an economic assessment detailed in Exhibit H, Tab 1, Schedule 1, Attachment 1 of HONI’s leave to construct application. These alternatives included gas generation, CDM, battery storage, and FACTS devices. The outcome of the economic assessment in the 2021 Addendum Study showed that the Project is the most cost-effective option to meet the supply capacity need in the Richview South area.

Since the publication of the 2021 Toronto Addendum Study, there have been a number of new developments that impact the feasibility and cost-effectiveness of the gas generation, CDM and battery storage alternatives, and the cost and in-service date of the Project. These developments, and their impacts, are summarized in the sections below.

3.3.1. Gas Generation

In May 2023, Toronto City Council passed a motion to “oppose any new power generation proposal involving increased burning of fossil fuels, including natural gas” within the City of Toronto¹¹. There has also been historic opposition to siting natural-gas fired generation in both Mississauga and Oakville¹². It is likely that a gas generation alternative would receive limited local support in the current environment – and even if this alternative were to receive support, it is unlikely that a generator could be constructed prior to the contemplated in-service date of the Project as (among other things) there is currently no proponent seeking to undertake that construction work. Moreover, recent government policy direction to pursue other types of resources add to uncertainty around the future of gas generation in Ontario.¹³ Therefore, in addition to the high economic cost outlined in section 3.4, gas generation is not recommended to address the supply capacity need.

¹⁰ Assumes Dufferin TS on Manby supply.

¹¹ City Council Consideration on May 10, 2023. <https://secure.toronto.ca/council/agenda-item.do?item=2023.MM6.13>

¹² Ontario Liberals' gas-plants scandal: Everything you need to know. April 2015 <https://www.theglobeandmail.com/news/politics/ontario-liberals-gas-plants-scandal-everything-you-need-to-know/article23668386/>

¹³ Refer to *Powering Ontario's Growth* which outlines steps to meet provincial electricity needs of the 2030s and beyond and to create an emissions-free electricity system (<https://www.ontario.ca/page/powering-ontarios-growth>)

3.3.2. Conservation and Demand Management

The analysis of CDM alternatives performed in the 2021 Toronto Addendum was based on the 2019 Conservation Achievable Potential Study (“APS”) and included the forecasted effects of the 2021-2024 CDM Framework. In addition to the province-wide programs under the provincial framework, two incremental Local Initiatives Programs (“LIP”) have been launched for the Richview South area, which are estimated to achieve approximately 10 MW of peak savings by 2026.¹⁴ These LIP programs will help reduce reliability risk arising from electricity demand in Richview South until the Project can come into service.

In 2022, the APS was updated and identified no additional CDM potential, compared to that identified in the 2019 APS, for the near-term in the Toronto area¹⁵. Based on this, and accounting for the 10 MW of incremental CDM expected from the LIP programs, the conclusion from the 2021 Addendum that there is not enough cost-effective CDM potential to defer the in-service date of the Project beyond 2026 is still valid.

3.3.3. Battery Storage

Battery costs have been updated to be based on the moderate case for a 6-hour battery from NREL ATB 2022¹⁶. Batteries remain a non-viable alternative to the Project to meet the identified need for the reasons stated in the 2021 Toronto Addendum, which include the characteristics of the need and current battery technology and costs.

3.3.4. Richview to Manby Transmission Upgrade – the Project

In preparation for the Application, HONI notified the IESO that the capital cost of the Project increased to \$73 million. HONI has also notified the IESO that the targeted in-service date of the Project is March 2026. The IESO understands that this is the earliest in-service date possible at the time of this submission.

¹⁴ Preliminary results, at the time of this submission, indicate that the LIP is on track to meet this target.

¹⁵ Some of the potential materialized between 2019 and 2022 through the 2021-24 CDM Framework.

¹⁶ NREL ATB 2022 <https://data.openei.org/submissions/5716>

3.4. Updated Economic Analysis of Alternatives

The IESO has updated the economic analysis that was performed in the 2021 Toronto Addendum Study to determine if the Project is still cost-effective relative to alternatives, taking into account the updated information on alternatives described in Sections 3.3.1 to 3.3.4. This update uses the same assumptions as per the 2021 Addendum¹⁷, except for updated inflation (to include the most recent inflation numbers at the time of this submission), updated Project capital costs and in-service date (as described in 3.3.4), and battery storage costs (as described in 3.3.3). Table 2 presents the results of this updated analysis.

Note that, as the updated Metrolinx forecast in Section 3.1 was only received recently, the economic analysis was not updated to reflect this incremental demand. However, it is important to note that: (a) the Project is capable of meeting this incremental demand; and (b) the incremental demand will significantly increase the cost of non-wires alternatives (e.g. gas generation and battery storage) as they are specifically sized to meet the need. The cost of wires alternatives, such as the Project, will not be materially impacted by the increased Metrolinx forecast.

Table 2 | Updated Economic Analysis^{18,19}

Option	NPV (\$2022 millions)
Upgrade Richview to Manby corridor (the Project) for 2026	\$90
FACTS device installed in 2026, defer corridor upgrade to 2028	\$110
Gas-fired generation installed in 2026, defer corridor upgrade to 2031	\$395
Battery storage installed in 2026, defer corridor upgrade to 2031	\$475

The updated analysis shows that proceeding with the Project to be in-service by 2026 remains the most economic option to address the identified need. Deferring the transmission upgrade still proves to be costlier despite the capital cost of the Project in part because the cost of the alternatives has also increased since the 2021 Toronto Addendum analysis was done. Deferring the Project using FACTS devices increases the NPV by \$21 million relative to the NPV of the Project, while a gas-fired resource or a battery storage solution would incur hundreds of millions of dollars in incremental costs compared to the Project.

¹⁷ 2021 Addendum: <https://ieso.ca/-/media/Files/IESO/Document-Library/regional-planning/Toronto/Toronto-2021-Addendum.ashx>

¹⁸ The gas-fired generation and battery storage solutions were calculated with Dufferin TS supplied by the Leaside system. Assuming Dufferin TS supplied by the Manby system would lead to even higher NPVs as it would require the gas-fired and battery storage solutions to meet greater energy and peak requirements.

¹⁹ Costs of FACTS devices are the same as used in 2021 Addendum, while the costs of gas-fired generation and battery storage were updated with the latest available information as of this submission. Given inflationary pressures, the costs of the FACTS devices have likely increased since the 2021 Addendum was published.

4. Conclusion and Recommended Solution

The Richview to Manby transmission corridor upgrade has been considered in various Toronto regional plans since the first Toronto Region IRRP was published in 2015. The latest regional plan, the 2021 Toronto Addendum, reaffirmed the need to upgrade the corridor as soon as possible. The most recent information on actual historical electricity demand in the area indicates that, in fact, the need exists today and the risk of an event resulting in loss of load will increase as demand grows.

Early indications in the third cycle of regional planning show that Toronto is embarking on a period of growth driven by electrification and is expected to be decoupled from historical growth rates. These developments suggest that the demand in the Richview South area is likely to exceed current forecasts.

The IESO's updated economic analysis shows that the corridor upgrade remains the most cost-effective option to address the supply capacity need and growing power demands of the Richview South area. While increased demand from electrification and grid de-carbonization may cause the area to grow further than currently forecast, any increase in demand will only serve to increase cost of non-wires alternatives while the cost of the Project will not be materially impacted. The amount of incremental demand that can be expected from electrification and grid de-carbonization is not yet known, but the IESO will continue to monitor demand in the area and identify any incremental needs that emerge through the ongoing regional planning process. The Project will help strengthen the system, providing a foundation for further expansion and growth as needed.

Therefore, the IESO continues to recommend the Project to address the Richview South capacity need and recommends that HONI proceed with the Project to be in-service as soon as possible.

**Independent Electricity
System Operator**

1600-120 Adelaide Street West
Toronto, Ontario M5H 1T1

Phone: 905.403.6900

Toll-free: 1.888.448.7777

E-mail: customer.relations@ieso.ca

ieso.ca

 [@IESO_Tweets](https://twitter.com/IESO_Tweets)

 [linkedin.com/company/IESO](https://www.linkedin.com/company/IESO)

1 **PROJECT CATEGORIZATION AND CLASSIFICATION**

2
3 **PROJECT CATEGORIZATION**

4 Subsection 4.3.2.4 of the Board's Filing Requirements requires applicants to categorize
5 projects as being either discretionary or non-discretionary. Non-discretionary project
6 characteristics include:

- 7
- 8 a) mandatory requirements to satisfy reliability standards set by standards authorities
9 including NPCC/NERC or the IESO;
 - 10 b) a need to connect new load (of a distributor or large user) or new generation
11 connection;
 - 12 c) a need to address equipment loading or voltage/short circuit stresses when their
13 rated capacities are exceeded;
 - 14 d) a transmission project that the transmitter is required by its licence to develop and
15 seek approvals for;
 - 16 e) projects identified in a provincial government approved plan;
 - 17 f) projects that are required to achieve provincial government objectives that are
18 prescribed in governmental directives or regulations; and
 - 19 g) priority transmission projects declared by Lieutenant Governor in Council order
20 that the construction, expansion, or reinforcement of an electricity transmission line
21 is needed as a priority project.

22

23 Based upon the above criteria, Hydro One submits that the Etobicoke Greenway Project
24 is properly categorized as a non-discretionary project as it is being undertaken at the
25 request of the IESO as described in **Exhibit B, Tab 3, Schedule 1**. The Project will
26 increase the transfer capability between Richview TS and Manby TS and it will support
27 the forecast load growth in the Southwest GTA.

1 **PROJECT CLASSIFICATION**

2 Projects are classified into three groups based on their purpose.

- 3 • Development Projects, which most closely align with the System Service category
4 as defined in Chapter 5 of the OEB Filing Requirements for Utility System Plans,
5 are those which:
 - 6 i. provide an adequate supply capacity and/or maintain an acceptable or
7 prescribed level of customer or system reliability for load growth or for
8 meeting increased stresses on the system; or
 - 9 ii. enhance system efficiency such as minimizing congestion on the
10 transmission system and reducing system losses.
- 11
- 12 • Connection Projects, which most closely align with the System Access category
13 as defined in Chapter 5 of the OEB Filing Requirements for Utility System Plans,
14 are those which provide connection of a load or generation customer or group of
15 customers to the transmission system.
- 16
- 17 • Sustainment Projects, which most closely align with the System Renewal category
18 as defined in Chapter 5 of the OEB Filing Requirements for Utility System Plans,
19 are those which maintain the performance of the transmission network at its
20 current standard or replace end-of-life facilities on a “like for like” basis.

21

22 Based on the above criteria, the Etobicoke Greenway Project is a Development Project
23 as the proposed transmission facilities provide for additional supply capacity and maintain
24 reliability and quality of electricity supply.

25

Categorization and Classification

		Project Need	
		Non-discretionary	Discretionary
Project Class	Development	X	

COST BENEFIT ANALYSIS AND OPTIONS

As described in **Exhibit B, Tab 3, Schedule 1**, the 230 kV transmission corridor between Richview TS and Manby TS is the main supply path for the western half of the City of Toronto. It also supplies load in the southern Mississauga and Oakville areas via Manby TS. The corridor has two 230 kV double-circuit transmission lines (R1K/R2K and R13K/R15K) and one idle 115 kV double-circuit transmission line (K9S/K10SB).

An analysis of alternatives to meet the supply capacity needs in the Southwest GTA was undertaken by the Toronto Regional Planning Working Group (Hydro One, IESO, and Toronto Hydro) most recently in the 2019 Toronto Region IRRP, the 2020 Toronto RIP, and the 2021 Toronto IRRP Addendum reports which are all included as Attachments to **Exhibit H, Tab 1, Schedule 1**. The reports conclude that the recommended path forward to address the Southwest GTA supply capacity need is to replace the existing idle 115 kV double-circuit transmission line with a new 230 kV double-circuit transmission line. The need and recommended solution for the Project has been reaffirmed by the IESO as documented in **Exhibit B, Tab 3, Schedule 1, Attachment 1**.

Hydro One considered two alternatives for building the new transmission line¹:

Alternative 1 – Build the new 230 kV double-circuit transmission line using the 1443 kcmil ACSR/TW conductor. This is the same conductor used on the two existing 230 kV double-circuit transmission lines between Richview TS and Manby TS.

Alternative 2 - Build the new 230 kV double-circuit transmission line using the 1780 kcmil ACSR/TW conductor². This is the next larger size conductor and would reduce line losses as compared to the conductor used under Alternative 1.

¹ Considered alternatives discussed in this section are limited to alternatives that could reasonably and cost-effectively meet the preferred in-service date of the IESO.

1 For both alternatives, Hydro One had initially, during the development phase of the
2 project, considered using the standard construction approach for building the line.
3 However, as identified in the Final ESR, filed with the MECP on June 5, 2023, the area
4 the line traverses is an environmentally sensitive dense urban area, and line
5 construction³ requires taking special environmental mitigation measures and is not
6 directly comparable to other transmission line builds in the province. The standard
7 construction approach therefore is not feasible to deliver the Project because it would
8 not comply with the environmental mitigations and commitments documented in the
9 Final ESR. The costs associated with the environmental mitigations and commitments
10 are documented and further described in **Exhibit B, Tab 7, Schedule 1, Table 2.**

11

12 **ANALYSIS AND RECOMMENDATIONS**

13 Alternatives 1 and 2 described above satisfy the supply capacity need to support the
14 forecast load growth in the Southwest GTA in a manner consistent with the IESO's
15 ORTAC criteria and other regulatory requirements. The following screening analysis
16 considers the impact of line losses. The line loss analysis summarized below is based
17 on the process outlined in Hydro One's Transmission Line Loss Guideline.

² Incremental capital costs associated with the installation of any standard conductor greater than the 1780 kcmil ACSR/TW conductor materially offset the NPV of the potential losses savings those conductors would provide and were therefore not explored.

³ The planned construction methodology for the Project includes installation of rider poles, temporary bypass and utilizing the existing conductor to undertake stringing of new 1780 ACSR/TW conductor. This also includes construction of larger granular staging areas at each tower location to install the temporary bypass.

1

Table 1 - Screening Analysis

	Alt. #1 (1443 kcmil ACSR/TW)	Alt. #2 (1780 kcmil ACSR/TW)
Capital Cost (\$M)	72.6	73.1
Losses at Peak Flow (MW)⁴	0.538	0.449
Annual Revenue Costs (\$M)	5.50	5.54
Annual Cost of losses⁵ (\$M)	0.22	0.19
Total Annual Cost (\$M)	5.72	5.72

2

3 The screening analysis showed similar Total Annual Costs for both alternatives, so a
 4 detailed 50-year NPV analysis was conducted. The NPV used a 5.65% discount rate, to
 5 evaluate which conductor alternative provided the best NPV result. A NPV sensitivity
 6 analysis was also done using varying values for the price of energy.

7

8 The results of the NPV energy price sensitivity analysis is provided in Table 2 below.

9

10

Table 2 - NPV Sensitivity Analysis of Alternatives

	Alt. #1 (1443 kcmil ACSR/TW)	Alt. #2 (1780 kcmil ACSR/TW)
Capital cost (\$M)⁶	72.6	73.1
Annual Losses (MWHR)	3090	2584
	Alt. #1 (1443 kcmil ACSR/TW)	Alt. #2 (1780 kcmil ACSR/TW)
Energy Price (\$/MWHR)		
\$47.30	-64.05	-64.02
\$120.00	-68.53	-67.78

⁴ Losses based on 2026 forecast flows.

⁵ Losses calculated based on 2022 average HOEP of \$47.30/MWHR. Hydro One does not have any basis to deviate from the HOEP and it is the only current settlement mechanism to recover transmission line loss costs.

⁶ Cost includes capital cost and removal cost.

- 1 The NPV analysis shows that Alternative #2 is more economical than Alternative #1,
- 2 regardless of the energy price. Both alternatives meet the capacity needs for the area,
- 3 but based on the analysis above, Alternative #2 is selected as the preferred and
- 4 recommended plan.

1 **QUANTITATIVE AND QUALITATIVE BENEFITS OF THE PROJECT**

2
3 System benefits delivered by the Project are predominantly documented in the IESO
4 Report found at **Exhibit B, Tab 3, Schedule 1, Attachment 1**.

5
6 The new transmission line facilities and the way the Project will be delivered ensures
7 that the growing load in the Southwest GTA can be adequately supplied by the required
8 in-service date and addresses community concerns as unearthed through the Class EA
9 process.

10
11 Hydro One also conducted economic analysis to investigate ratepayer impacts with
12 respect to transmission line losses. The NPV energy price sensitivity analysis confirms
13 that the 1780 kcmil ACSR/TW conductor is the most prudent method to meet the needs
14 of the Project. The results of that analysis are further discussed in **Exhibit B, Tab 5,**
15 **Schedule 1**.

This page has been left blank intentionally.

APPORTIONING PROJECT COSTS AND RISKS

The estimated capital cost of the RxM Project is shown below:

Table 1 - Total Cost

	Estimated Cost (\$000's)
Materials	14,217
Labour	19,199
Equipment Rental & Contractor Costs	21,287
Sundry	1,801
Contingencies	7,000
Overhead ¹	4,305
Allowance for Funds Used During Construction ²	4,422
Real Estate	900
Total Cost³	73,131

The cost of the work provided above allows for the schedule of approval, design, and construction activities provided in **Exhibit B, Tab 11, Schedule 1**.

The cost estimates provided in Table 1 of this Schedule, and similarly, the Project Schedule provided at **Exhibit B, Tab 11, Schedule 1**, are based on a project definition equivalent to a Class 3⁴ under the AACE International (formerly the Association for the

¹ Overhead Costs allocated to the Project are for corporate services costs. These costs are charged to capital projects through a standard overhead capitalization rate. As such they are considered "Indirect Overhead".

² AFUDC is calculated using the Board's approved interest rate methodology (EB-2016-0160) to the Project's forecast monthly cash flow and carrying forward closing balances from the preceding month.

³ Total Cost includes the line work (\$72,631K) and station work (\$500K) costs. The station work is minimal (including protection, controls and telecom setting changes) and therefore is not represented in its own table.

⁴ An estimate range of -20%/+30%.

1 Advancement of Cost Engineering) estimate classification system⁵ and the Project has
2 completed preliminary engineering and design activities (approximately 60% complete).

3
4 The project cost estimate was developed using internal cost estimate tools and
5 techniques.

6 7 **1.0 RISKS AND CONTINGENCIES**

8 As with most projects, there are risks associated with estimating costs. Hydro One's cost
9 estimate includes an allowance for contingencies in recognition of these risks.

10
11 The Project risks that predominantly contribute to the total contingency suggested for this
12 project include the following:

- 13 • **Encroachments** - Various objects and backyard extensions have been identified
14 along the corridor which could impact line construction and operation.
- 15 • **Subsurface Conditions** – Subsurface or environmental conditions that may
16 require additional mitigations or delay or stop construction progress.
- 17 • **Approvals and Permit Delays** – Risk of delays in obtaining required approvals
18 including leave to construct.

19
20 To mitigate these risks Hydro One has:

- 21 1. Completed design reviews to support the engineering technical review of the
22 Project including a review of any existing ROW encroachments' impacts on the
23 line construction and operations.
- 24 2. Implemented technical solutions such as bonding, installing alternative tower
25 designs in certain areas, adding grounding, and re-positioning towers further away
26 from properties, where feasible.
- 27 3. Developed a robust Community Engagement Plan as part of the EA process that
28 outlines proactive measures to preserve vegetation, efforts to offset residual

⁵ As per 96r-18 Cost Estimate Classification System.

1 project impacts, engage with the public, provide reassurance regarding safety
2 measures, respond to inquiries, and manage expectations.

3 4. Proactively submitted all regulatory applications, in accordance with those
4 applications' filing requirements, well in advance of the construction start date of
5 the Project including finalizing the ESR with the MECP and this leave to construct
6 application.

7

8 Cost contingencies that have not been included in the total contingency suggested for this
9 project, due to the unlikelihood or uncertainty of occurrence, include:

- 10 • Labour disputes;
- 11 • Safety or environmental incidents;
- 12 • Receipt of damaged materials;
- 13 • Significant changes in costs of materials outside the control of Hydro One since
14 the estimate preparation; and
- 15 • Any other unforeseen and potentially significant event/occurrence.

16

17 **2.0 COSTS OF COMPARABLE PROJECTS - LINES**

18 The OEB Filing Requirements for *Electricity Transmission Applications, Chapter 4*,
19 requires the Applicant to provide information about a cost comparable project constructed
20 by the Applicant. Table 2 compares the line cost of this Project with three other recent
21 comparable projects:

22

- 23 • **Power South Nepean Project:** Upgraded an existing 115 kV single-circuit
24 transmission line to construct a new 230 kV double-circuit transmission line
25 (approximately 12.2 km) to address capacity needs in the South Nepean Area of
26 Ottawa. The new 230 kV double-circuit line transmission replaced approximately
27 10.9 km of the existing 115 kV single-circuit transmission line (S7M) from West
28 Hunt Club Road to Cambrian Road and extended an additional approximate
29 1.3 km from Cambrian Road to the new MTS. Leave to construct approval for this
30 project was provided under OEB docket EB-2019-0077.

- 1 • **Riverdale JCT x Overbrook TS Line Rebuild Project:** Rebuild of an existing
2 1.9 km line section of A5RK from Riverdale JCT to Overbrook TS as a 115 kV
3 double-circuit transmission line and reconnect Overbrook TS to address growing
4 demand on the 115 kV system in the Overbrook and Vanier areas in Ottawa. One
5 circuit of the new line was used for circuit A5RK. The second circuit on the new
6 line tapped the A6R 115 kV circuit at Riverside JCT to pick up Overbrook TS. This
7 project was exempt from leave to construct approval pursuant to Ontario
8 Regulation 161/99 of the *Ontario Energy Board Act, 1998*.
- 9 • **Guelph Area Transmission Refurbishment Project:** Upgraded an existing
10 115 kV double-circuit transmission line to construct a new 230 kV double-circuit
11 transmission line (approximately 5 km) to reinforce the electricity supply and
12 minimize the impact of major transmission outages on customers in the area. The
13 majority of the line upgrade work involved replacing the existing 115 kV double
14 wood pole line, B5G/B6G, between CGE Junction and Campbell TS, with a 230 kV
15 line utilizing a combination of steel lattice towers and steel pole structures. Leave
16 to construct approval for this project was provided under OEB docket EB-2013-
17 0053.

18
19 These projects were selected as reasonable comparable projects because they were
20 constructed using both steel poles and steel lattice structures and they included a rebuild
21 of an existing 115 kV transmission line and structures. More specifically, the Power South
22 Nepean and the Guelph Area Transmission Reinforcement Projects were selected as
23 reasonably comparable projects because they included an upgrade from 115 kV to 230 kV
24 voltage akin to this Project. The Riverdale JCT x Overbrook TS Project was selected
25 because it was a project utilizing a similarly sized conductor that was contemplated as a
26 feasible alternative to execute this Project (as described in **Exhibit B, Tab 5, Schedule**
27 **1**), and was also geographically situated in an urban area.

28
29 For the purposes of the comparison, Hydro One has excluded costs associated with
30 encroachments and/or real estate, bypass and rider poles, micropile foundations, structure

1 bonding, as well as environmental commitments/mitigations driven by the Final ESR filed
2 with the MECP.

3
4 Most of the environmental mitigations are attributed to reimagining the hydro corridor
5 (\$10.4 million) and costs that are forecast to preserve vegetation in the area (\$9.5 million)
6 including century-old trees necessitated by the commitments made as part of the Final
7 ESR.

8
9 Flowing from the above mitigations, Hydro One has also removed from the comparison
10 bypass and rider poles that are required to construct the RxM Project to meet the above
11 environmental commitments. Consequently, similar costs are also excluded from the
12 comparable projects as shown for the Power South Nepean Project.

13
14 Adjustment was also made for the region topography that would impact construction,
15 notably, the use of micropile foundations based on terrain characteristics along the
16 corridor. This again, results in adjustments to both the RxM Project and the Power South
17 Nepean Project.

18
19 Hydro One has eliminated the real estate and/or encroachment, and structure bonding
20 costs from the comparable projects because these are project-specific requirements and
21 not comparable between projects and because one of the projects, the Riverdale JCT x
22 Overbrook TS Project, did not require any real estate acquisition and/or encroachment
23 costs.

24
25 Additionally, Table 2 does not take into consideration impacts related to outage availability.
26 As described in **Exhibit B, Tab 3, Schedule 1, Attachment 1**, there is no local
27 transmission-connected generation within the Richview South area; the Richview TS to
28 Manby TS corridor is effectively the only supply to this area. The consequence, therefore,
29 atypical to other projects such as the Power South Nepean Project that has redundancy
30 in the area, is that outage availability can be a challenge based on loading and circuit

- 1 capacity for the RxM Project. The result is that outages can only be granted at certain
- 2 times of the year resulting in increased labour and carrying costs for the Project.

1

Table 2 - Costs of Comparable Line Projects

Project	Power South Nepean Project (Line Cost)	Riverdale JCT x Overbrook TS Line Rebuild Project (Line Cost)	Guelph Area Transmission Refurbishment Project (Line Cost)	Richview TS x Manby TS Line Rebuild (Line Cost)
Circuit Operating Designation(s)	S7M and E34M	A6R and A5RK	D6V and D7V	New R15K super circuit
Voltage	230 kV	115kV	230 kV	230 kV
Structure Type	Steel Pole Steel Lattice	Steel Pole Steel Lattice	Steel Pole Steel Lattice	Steel Pole Steel Lattice
Single or Double Circuit	Double	Double	Double	Double
Conductor	997 kcmil	1443 kcmil	1192 kcmil	1780 kcmil
Location	Ottawa	Ottawa	Southwest Ontario	Southwest GTA
Project Surroundings	Urban-Rural Parallel to Hwy 416	Urban	Urban Parallel to Hwy 6	Urban Dense Area
In-Service Year	2021	2019	2016	2026
Estimate or Actual	Actual	Actual	Actual	Estimate
OEB-Approved Cost Estimate	\$58.8M ⁶	N/A ⁷	\$27.5M ⁸	--
Total Cost	\$51,276K	\$9,830K	\$23,485K	\$72,281K ⁹
Less Adjustments:				
<i>Encroachments / Real Estate</i>	\$2,229K	\$0K	\$1,187K	\$2,500K
<i>Bypass / Rider poles</i>	\$1,419K	\$0K	\$0K	\$5,831K
<i>Structure Bonding</i>	\$0K	\$0K	\$0K	\$2,500K
<i>Micropile Foundation</i>	\$6,730K	\$0K	\$0K	\$960K
<i>Environmental Commitments</i>	\$0K	\$0K	\$0K	\$19,917K
Comparable Cost, before Escalation	\$40,898K	\$9,830K	\$22,299K	\$40,573K
Escalation Adjustment¹⁰	\$8,176K	\$2,564K	\$7,352K	--
Total Adjusted Comparable Cost	\$49,073K	\$12,394K	\$29,651K	\$40,573K
Approximate Length	12.2km	1.9km	5.0km	6.5km
Unit Cost	\$4,022K/km	\$6,523K/km	\$5,930K/km	\$6,242K/km

⁶ As per Section 92 leave to construct proceeding EB-2019-0077.

⁷ This project was encompassed within a previous Hydro One revenue requirement application. The project was not subject to leave to construct approval by the OEB. Therefore, the specific investment does not have a discrete OEB approval to appropriately reference for the purposes of this comparison.

⁸ As per Section 92 leave to construct proceeding EB-2013-0053.

⁹ Total cost excludes the costs for the upgrade of K21C (\$350K).

¹⁰ Inflation adjustment factors used for comparator projects are consistent with the OEB's annual inflation parameters for electricity transmitters' rate applications.

1 When considering the cost per km ratio for all other transmission line costs in Table 2, the
2 comparable projects demonstrate that the estimate for the RxM Project is in line with the
3 cost to complete comparable transmission line works and is reasonable.

4
5 Table 2 has been adjusted to show comparable projects in 2026 dollars utilizing inflation
6 values for future years consistent with the inflation parameters provided by the OEB. Much
7 has changed in the industry since the comparable projects were placed in service which
8 has impacted costs for infrastructure projects, e.g., COVID-19, global supply chain issues,
9 and escalating inflation levels. As described in Hydro One's revenue requirement
10 application¹¹, external pressures on the industry have caused price increases across the
11 industry. The price of essential commodities has a significant impact on project costs.
12 Equipment purchased to construct transmission lines (e.g., tower steel and conductor) is
13 heavily impacted by certain raw material indices. Essential commodities such as copper,
14 aluminum, and steel have undergone price increases and supply shortages.

16 **3.0 COSTS OF COMPARABLE PROJECTS – STATIONS**

17 The cost of the station work at Richview TS and Manby TS work includes only protection,
18 controls, and telecom settings changes. This work represents less than 1% of the total
19 project cost and does not meet Hydro One's materiality threshold. Consequently, the
20 forecast estimate to deliver that component of the Project has not been compared relative
21 to other projects to support the reasonability of the station work cost estimate.

¹¹ EB-2021-0110 – Exhibit O, Tab 1, Schedule 2 – Filed March 31, 2022.

1 **CONNECTION PROJECTS REQUIRING NETWORK REINFORCEMENT**

2

3 This is not a connection project. Facilities being constructed as part of this Project are
4 limited to those discussed in the details of the work being undertaken in **Exhibit C, Tab**
5 **1, Schedule 1.**

This page has been left blank intentionally.

TRANSMISSION RATE IMPACT ASSESSMENT

1.0 ECONOMIC FEASIBILITY

The proposed Project consists of replacing an existing idle 115 kV double-circuit transmission line with new 230 kV double-circuit transmission line between Richview TS and Manby TS and modifying and reconfiguring the existing circuits R1K, R2K, R13K and R15K between the two stations. The costs for the upgrade of the circuits will be included in the Network connection pool for cost classification purposes and not allocated to any individual customer.

Once in service, the Project will increase the transfer capability between Richview TS and Manby TS to support incremental load growth of 334MW in the western half of the City of Toronto, southern Mississauga and Oakville areas, resulting in approximately \$17.2 million in annual incremental network revenue over a 25-year evaluation period utilizing the 2023 UTR. Incremental annual operating and maintenance costs for the proposed Project will be approximately \$30K for the 6.5 km of 230 kV double-circuit transmission line and additional vegetation maintenance. The vegetation maintenance costs are based on average unit cost of the forestry program for this area, and the incremental costs associated with the commitment in the Final ESR to preserve existing vegetation in the corridor.

The discounted cash flow analysis shown in Tables 1 and 2 conclude that based on the estimated initial cost of \$73.1¹ million, plus the assumed impact on the future capital cost allowance and Hydro One corporate income tax, the Project will have a positive net present value of \$50.6 million.

¹ Initial costs of \$73.1 million include \$71.3 million of up-front capital costs plus \$1.8 million cost of removals.

1 **2.0 COST RESPONSIBILITY**

2 **Network Pool**

3 The Project will increase the transfer capability between Richview TS and Manby TS and
4 is required to supply incremental load growth of 334MW in the western half of City of
5 Toronto, southern Mississauga and Oakville areas. This Project is not associated with
6 any specific load increase or customer load application.

7
8 While Richview TS is already a network station, the Manby TS West 230 kV bus, and the
9 modified R2K and R15K circuits will be reclassified as “network facility” as per Section
10 3.0.14 and 3.0.15 of the Transmission System Code since the proposed work is being
11 carried out to increase capacity. No customer capital contribution is required, consistent
12 with the provisions of Section 6.3.5 of the Transmission System Code.

13
14 **3.0 RATE IMPACT ASSESSMENT**

15 The analysis of the Network pool rate impacts has been carried out based on Hydro One’s
16 transmission revenue requirement for the year 2023, and the 2023 approved Ontario
17 Transmission Rate Schedules. The Network pool revenue requirements would be affected
18 by the Project based on the project cost allocation.

19
20 **Network Pool**

21 Based on the Project’s initial cost of \$73.1 million and the associated network pool
22 incremental cash flows, there will be a change in the network pool revenue requirement
23 once the Project’s impacts are reflected in the transmission rate base at the projected in-
24 service date of March 30, 2026. Due to the enabled growth in the Southwest GTA, the
25 steady net incremental revenue will have an overall rate mitigating impact over the 25-
26 year time horizon. The 2023 OEB approved rate of \$5.37 per kW/month decreases to
27 \$5.36 per kW/month in year 5, \$5.34 per kW/month in year 10, and \$5.32 per kW/month
28 from year 15 onwards. The detailed analysis illustrating the calculation of the incremental
29 network revenue and rate impact is provided in Tables 3 and 4.

1 **Impact on Typical Residential Customer**

2 Based on the load forecast, initial capital costs and ongoing maintenance costs, adding
 3 the costs of the required facilities to the Network pool will cause a \$0.08 per month
 4 decrease in a typical residential customer's rates under the RPP. The table below shows
 5 this result for a typical residential customer who is under the RPP, utilizing the maximum
 6 impact by rate pool, regardless of year.

7

A. Typical monthly bill	\$135.28 per month
B. Transmission component of monthly bill	\$15.33 per month
C. Line Connection Pool share of Transmission component	\$1.49 per month
D. Transformation Connection Pool share of Transmission component	\$5.05 per month
E. Network Connection Pool share of Transmission component	\$8.80 per month
F. Impact on Line Connection Pool Provincial Uniform Rates	0.00%
G. Impact on Transformation Connection Pool Provincial Uniform Rates	0.00%
H. Impact on Network Connection Pool Provincial Uniform Rates	-0.93%
I. Decrease in Transmission costs for typical monthly bill (E x H)	\$-0.08 per month or \$-0.98 per year
J. Net decrease on typical residential customer bill (I / A)	-0.06%

1

Table 1 - Net Present Value, Page 1

Month Year	In-Service Date		Project year ended - annualized from In-Service Date												
	Mar-30	Mar-30	Mar-30	Mar-30	Mar-30	Mar-30	Mar-30	Mar-30	Mar-30	Mar-30	Mar-30	Mar-30	Mar-30	Mar-30	
	2026	2027	2028	2029	2030	2031	2032	2033	2034	2035	2036	2037	2038	2038	
			0	1	2	3	4	5	6	7	8	9	10	11	12
Revenue & Expense Forecast															
Load Forecast (MW)			60.8	75.6	87.4	103.0	122.6	136.3	150.3	164.5	178.9	193.6	208.5	223.8	
Load adjustments (MW)			0.0	0.0	0.0	0.0	0.0	0.0	0.0	0.0	0.0	0.0	0.0	0.0	
Tariff Applied (\$/KW/Month)			5.37	5.37	5.37	5.37	5.37	5.37	5.37	5.37	5.37	5.37	5.37	5.37	
Incremental Revenue - \$M			3.9	4.9	5.6	6.6	7.9	8.8	9.7	10.6	11.5	12.5	13.4	14.4	
Removal Costs - \$M		(1.8)													
On-going OM&A Costs - \$M		0.0	(0.0)	(0.0)	(0.0)	(0.0)	(0.0)	(0.0)	(0.0)	(0.0)	(0.0)	(0.0)	(0.0)	(0.0)	
Municipal Tax - \$M			(0.2)	(0.2)	(0.2)	(0.2)	(0.2)	(0.2)	(0.2)	(0.2)	(0.2)	(0.2)	(0.2)	(0.2)	
Net Revenue/(Costs) before taxes - \$M		(1.8)	3.7	4.6	5.4	6.4	7.6	8.5	9.4	10.3	11.3	12.2	13.2	14.2	
Income Taxes			0.5	(0.2)	0.2	(0.1)	(0.5)	(0.9)	(1.2)	(1.6)	(1.9)	(2.2)	(2.5)	(2.8)	(3.1)
Operating Cash Flow (after taxes) - \$M			(1.3)	3.4	4.6	5.3	5.9	6.7	7.3	7.9	8.5	9.1	9.7	10.4	11.1
			Cumulative PV @ 5.65%												
PV Operating Cash Flow (after taxes) - \$M	(A)	121.6	(1.3)	3.3	4.4	4.6	4.9	5.3	5.4	5.5	5.6	5.7	5.8	5.8	5.9
Capital Expenditures - \$M															
Upfront - capital cost before overheads & AFUDC		(62.6)													
- Overheads		(4.3)													
- AFUDC		(4.4)													
Total upfront capital expenditures		(71.4)													
On-going capital expenditures			0.0	0.0	0.0	0.0	0.0	0.0	0.0	0.0	0.0	0.0	0.0	0.0	
PV On-going capital expenditures			0.0	0.0	0.0	0.0	0.0	0.0	0.0	0.0	0.0	0.0	0.0	0.0	
Total capital expenditures - \$M		(71.4)													
Capital Expenditures - \$M															
PV CCA Residual Tax Shield - \$M		0.4													
PV Working Capital - \$M		(0.0)													
PV Capital (after taxes) - \$M	(B)	(71.0)	(71.0)												
Cumulative PV Cash Flow (after taxes) - \$M (A) + (B)		50.6	(72.3)	(69.0)	(64.5)	(59.9)	(55.1)	(49.8)	(44.4)	(38.9)	(33.3)	(27.6)	(21.9)	(16.1)	(10.2)

Discounted Cash Flow Summary		Other Assumptions	
Economic Study Horizon - Years:	25	In-Service Date:	30-Mar-26
Discount Rate - %	5.65%	Payback Year:	2040
	\$M	No. of years required for payback:	14
PV Incremental Revenue	156.4		
PV O&M&A Costs	(2.2)		
PV Municipal Tax	(3.2)		
PV Income Taxes	(40.0)		
PV CCA Tax Shield	10.9		
PV Capital - Upfront	(71.4)		
Add: PV Capital Contribution	0.0		
PV Capital - On-going	0.0		
PV Working Capital	(0.0)		
PV Surplus / (Shortfall)	50.6		
Profitability Index*	1.7		

Notes:
 *PV of total cash flow, excluding net capital expenditure & on-going capital & proceeds on disposal / PV of net capital expenditure & on-going capital & proceeds on disposal

1

Table 2 - Net Present Value, Page 2

Month Year	Project year ended - annualized from In-Service Date												
	Mar-30 <u>2039</u> 13	Mar-30 <u>2040</u> 14	Mar-30 <u>2041</u> 15	Mar-30 <u>2042</u> 16	Mar-30 <u>2043</u> 17	Mar-30 <u>2044</u> 18	Mar-30 <u>2045</u> 19	Mar-30 <u>2046</u> 20	Mar-30 <u>2047</u> 21	Mar-30 <u>2048</u> 22	Mar-30 <u>2049</u> 23	Mar-30 <u>2050</u> 24	Mar-30 <u>2051</u> 25
Revenue & Expense Forecast													
Load Forecast (MW)	239.3	255.1	267.2	267.2	267.2	267.2	267.2	267.2	267.2	267.2	267.2	267.2	267.2
Load adjustments (MW)	0.0	0.0	0.0	0.0	0.0	0.0	0.0	0.0	0.0	0.0	0.0	0.0	0.0
Tariff Applied (\$/kW/Month)	239.3	255.1	267.2	267.2	267.2	267.2	267.2	267.2	267.2	267.2	267.2	267.2	267.2
Incremental Revenue - \$M	<u>5.37</u>	<u>5.37</u>	<u>5.37</u>	<u>5.37</u>	<u>5.37</u>	<u>5.37</u>	<u>5.37</u>	<u>5.37</u>	<u>5.37</u>	<u>5.37</u>	<u>5.37</u>	<u>5.37</u>	<u>5.37</u>
Removal Costs - \$M	15.4	16.4	17.2	17.2	17.2	17.2	17.2	17.2	17.2	17.2	17.2	17.2	17.2
On-going OM&A Costs - \$M	(0.0)	(0.0)	(0.0)	(0.0)	(0.0)	(0.0)	(0.0)	(0.0)	(0.0)	(0.0)	(0.0)	(0.0)	(0.0)
Municipal Tax - \$M	(0.2)	(0.2)	(0.2)	(0.2)	(0.2)	(0.2)	(0.2)	(0.2)	(0.2)	(0.2)	(0.2)	(0.2)	(0.2)
Net Revenue/(Costs) before taxes - \$M	15.2	16.2	17.0	17.0	17.0	17.0	17.0	17.0	17.0	17.0	17.0	17.0	17.0
Income Taxes	(3.4)	(3.8)	(4.0)	(4.0)	(4.1)	(4.1)	(4.1)	(4.2)	(4.2)	(4.2)	(4.2)	(4.3)	(4.3)
Operating Cash Flow (after taxes) - \$M	<u>11.7</u>	<u>12.4</u>	<u>12.9</u>	<u>12.9</u>	<u>12.9</u>	<u>12.8</u>	<u>12.8</u>	<u>12.8</u>	<u>12.8</u>	<u>12.7</u>	<u>12.7</u>	<u>12.7</u>	<u>12.7</u>
PV Operating Cash Flow (after taxes) - \$M (A)	<u>5.9</u>	<u>5.9</u>	<u>5.8</u>	<u>5.5</u>	<u>5.2</u>	<u>4.9</u>	<u>4.6</u>	<u>4.4</u>	<u>4.1</u>	<u>3.9</u>	<u>3.7</u>	<u>3.5</u>	<u>3.3</u>
Capital Expenditures - \$M													
Upfront - capital cost before overheads & AFUDC													
- Overheads													
- AFUDC													
Total upfront capital expenditures													
On-going capital expenditures	0.0	0.0	0.0	0.0	0.0	0.0	0.0	0.0	0.0	0.0	0.0	0.0	0.0
PV On-going capital expenditures													
Total capital expenditures - \$M													
Capital Expenditures - \$M													
PV CCA Residual Tax Shield - \$M													
PV Working Capital - \$M													
PV Capital (after taxes) - \$M (B)													
Cumulative PV Cash Flow (after taxes) - \$M (A) + (B)	<u>(4.3)</u>	<u>1.6</u>	<u>7.4</u>	<u>12.9</u>	<u>18.1</u>	<u>23.0</u>	<u>27.7</u>	<u>32.1</u>	<u>36.2</u>	<u>40.1</u>	<u>43.8</u>	<u>47.3</u>	<u>50.6</u>

1

Table 3 - Revenue Requirement and Network Pool Rate Impact, Page 1

		Project YE											
		30-Mar 2027	30-Mar 2028	30-Mar 2029	30-Mar 2030	30-Mar 2031	30-Mar 2032	30-Mar 2033	30-Mar 2034	30-Mar 2035	30-Mar 2036	30-Mar 2037	30-Mar 2038
Richview TS x Manby TS Transmission Reinforcement													
Calculation of Incremental Revenue Requirement (\$000)		1	2	3	4	5	6	7	8	9	10	11	12
In-service date	30-Mar-26												
Capital Cost	71,369												
Less: Capital Contribution Required	-												
Net Project Capital Cost	71,369												
Average Rate Base		34,980	69,255	67,846	66,436	65,027	63,617	62,208	60,799	59,389	57,980	56,571	55,161
Incremental OM&A Costs		30	30	30	30	30	30	30	30	30	30	30	30
Grants in Lieu of Municipal tax		234	234	234	234	234	234	234	234	234	234	234	234
Depreciation		1,409	1,409	1,409	1,409	1,409	1,409	1,409	1,409	1,409	1,409	1,409	1,409
Interest and Return on Rate Base		2,219	4,393	4,304	4,214	4,125	4,036	3,946	3,857	3,767	3,678	3,589	3,499
Income Tax Provision		-36	-508	-371	-247	-134	-31	62	146	221	289	350	405
REVENUE REQUIREMENT PRE-TAX		3,857	5,559	5,606	5,642	5,665	5,678	5,682	5,676	5,662	5,641	5,613	5,578
Incremental Revenue		3,919	4,873	5,634	6,639	7,904	8,788	9,687	10,601	11,531	12,478	13,441	14,423
SUFFICIENCY/(DEFICIENCY)		62	-686	27	997	2,238	3,110	4,005	4,925	5,869	6,836	7,828	8,845
Network Pool Revenue Requirement including sufficiency/(deficiency)	Base Year	1,277,335	1,279,037	1,279,085	1,279,120	1,279,144	1,279,157	1,279,160	1,279,155	1,279,141	1,279,120	1,279,091	1,279,057
Network MW	1,273,479	237,814	237,992	238,133	238,320	238,556	238,721	238,888	239,058	239,231	239,407	239,587	239,770
Network Pool Rate (\$/kw/month)	5.37	5.37	5.37	5.37	5.37	5.36	5.36	5.35	5.35	5.35	5.34	5.34	5.33
Increase/(Decrease) in Network Pool Rate (\$/kw/month), relative to base year		0.00	0.00	0.00	0.00	-0.01	-0.01	-0.02	-0.02	-0.02	-0.03	-0.03	-0.04
RATE IMPACT relative to base year		0.00%	0.00%	0.00%	0.00%	-0.19%	-0.19%	-0.37%	-0.37%	-0.37%	-0.56%	-0.56%	-0.74%
Assumptions													
Incremental OM&A		Based on system average for the 6.5km of double circuit line and additional vegetation maintenance											
Grants in Lieu of Municipal tax	0.33%	Transmission system average											
Depreciation	2.00%	Reflects 50 year average service life for towers, conductors and station equipment, excluding land											
Interest and Return on Rate Base	6.34%	Includes OEB-approved ROE of 9.36%, 4.79% on ST debt, and 4.3% on LT debt. 40/4/56 equity/ST debt/ LT debt split											
Income Tax Provision	26.50%	2023 federal and provincial corporate income tax rate											
Capital Cost Allowance	8.00%	100% Class 47 assets except for Land											

2

Table 5 - DCF Assumption

**Hydro One Networks -- Transmission Connection Economic Evaluation Model
 2023 Parameters and Assumptions**

Transmission rates are based on current OEB-approved uniform provincial transmission rates.

Monthly Rate (\$ per kW)	
Network	5.37
Transformation	2.98
Line	0.88

Grants in lieu of Municipal tax (% of up-front capital expenditure, a proxy for property value):

0.33%

Based on Transmission system average

Income taxes:

Basic Federal Tax Rate -
 % of taxable income:

2023	15.00%
------	--------

Current rate

Ontario corporation income tax -
 % of taxable income:

2023	11.50%
------	--------

Current rate

Capital Cost Allowance Rate:

Class 47 costs
 Decision Support defined costs (1)
 Decision Support defined costs (2)
 Decision Support defined costs (3)

2023	8%
2023	0%
2023	0%
2023	0%

Current rate

After-tax Discount rate:

5.65%

Based on OEB-approved ROE of 9.36% on common equity and 4.79% on short-term debt, 4.3% forecast cost of long-term debt and 40/60 equity/debt split, and current enacted income tax rate of 26.5%

1 **REVENUE REQUIREMENT INFORMATION AND DEFERRAL**
2 **ACCOUNT REQUESTS**

3
4 **1.0 REVENUE REQUIREMENT AND TRANSMISSION SYSTEM PLAN INFORMATION**

5 The need for the Project was identified in the TSP included in Hydro One's most recent
6 revenue requirement application, EB-2022-0110 at Exhibit B, Tab 2, Schedule 1 Section
7 2.11 and more specifically discussed in ISD T-SS-06, provided as **Attachment 1 of this**
8 **Schedule** for ease of reference.

9
10 Though not explicitly required by the OEB's Chapter 4 Filing Requirements, Hydro One
11 recognizes that there is a cost difference between the forecast cost of \$23.1 million¹ that
12 underpinned the ISD and the cost to execute the project (\$73.1 million) that has been filed
13 in this Application at **Exhibit B, Tab 7, Schedule 1**. To address that difference, Hydro
14 One provides the following:

15
16 The ISD, filed August 5, 2021, predates the Notice of Commencement of the Class EA
17 process by approximately one full calendar year. The Class EA was initiated in June of
18 2022. Consequently, and as described in both **Exhibit B, Tab 5, Schedule 1** and **Exhibit**
19 **B, Tab 7, Schedule 1**, the environmental mitigation measures and commitments that have
20 been implemented in this Project as part of the Final ESR filed with the MECP to offset
21 project impacts were developed as a result of in-depth consultation with the impacted
22 community and were not originally contemplated at the time of filing the ISD.

23
24 The ISD was also predicated upon a less defined project scope, as partly illustrated above
25 through the pre-Class EA scope, and thus more closely, at best, reflects an AACE Class
26 4 estimate with an upper range of +50%. Conversely, the current project estimate is

¹ The forecast cost of \$23.1 million represents Phase 1 of the Project as contemplated by this leave to construct application. Furthermore, this forecast cost is from the prefiled evidence in OEB docket EB-2021-0110 and does not consider the specific impacts of inflation increases and settlement reductions noted in the OEB-approved Hydro One JRAP Settlement Proposal.

1 predicated upon an AACE Class 3 estimate range of +30/-20% as described in **Exhibit B,**
2 **Tab 7, Schedule 1.**

3

4 As also described in **Exhibit B, Tab 7, Schedule 1**, the ISD forecast cost does not reflect
5 many cost pressures that have arose in the industry, since the ISD forecast cost was
6 developed, that have impacted costs for infrastructure projects, e.g., COVID-19, global
7 supply chain issues and escalating inflation levels. For example, the OEB has recently
8 released the 2024 Inflation Factor to be used to set rates for electricity transmitters and
9 electricity distributors for 2024. The OEB has calculated the 2024 inflation factor for
10 electricity transmitters to be 5.4%². Inflationary cost pressures alone have increased by
11 more than 2.5 times since the filing of the ISD in 2021, where the 2021 inflation factor was
12 2.0% for electricity transmitters³.

13

14 Jointly, all the above items help describe why the forecast capital cost of the Project has
15 increased relative to the ISD. Importantly, however, with respect to revenue requirement
16 and as more specifically discussed in **Exhibit B, Tab 9, Schedule 1**, the effect of the
17 forecast cost given the forecast load the project enables to connect to the system will be
18 a reduction to the network connection uniform transmission rate relative to current rates
19 and an overall reduction to the typical residential customer's bill of 0.06%.

20

21 **2.0 DEFERRAL ACCOUNT REQUEST INFORMATION**

22 There are no new deferral account requests being made as part of this Application.

² OEB 2024 Inflation Parameters, June 29, 2023.

³ OEB 2021 Inflation Parameters, November 9, 2020.

T-SS-06	SOUTHWEST GTA TRANSMISSION REINFORCEMENT					
Primary Trigger:	Regional Planning					
OEB RRF Outcomes:	Customer Focus, Operational Effectiveness, Public Policy Responsiveness, Financial Performance					
Capital Expenditures:						
(\$ Millions)	2023	2024	2025	2026	2027	Total
Net Cost	6.5	7.5	3.0	0.0	1.0	18.0
Summary:						
<p>This investment involves reinforcing the transmission system between Richview TS and Manby TS to increase supply capacity in the South-West GTA. The work will be done in two stages: Stage 1 covers rebuilding an idle double circuit 115kV line as a double circuit 230kV line; and Stage 2 covers the station work to be completed later in coordination with future 230kV breaker replacement work at Manby TS. The in-service date for Stage 1 work is Q2 2025 and for Stage 2 work is Q2 2030.</p> <p>Hydro One is obligated to provide facilities required to maintain the reliability and integrity of its transmission system and reinforce or expand its transmission system as required to meet load growth in accordance with its Transmission License and the Transmission System Code. Failing to proceed with this investment would not allow Hydro One to meet its obligation as it would result in inadequate transmission capacity to supply load growth in the South-West GTA area. This investment is assigned a High Priority in order to meet this obligation.</p>						

1 **A. NEED AND OUTCOME**

2

3 **A.1 INVESTMENT NEED**

4 This investment is required to increase the transfer capability between Richview TS and Manby
5 TS to support the continued load growth in the South-West GTA area, as identified in the
6 Toronto Regional Infrastructure Plan (Toronto RIP found at SPF Section 1.2, Attachment 8). The
7 planned in-service date of the project is Q2 2025 for Stage 1 and Stage 2 following later in Q2
8 2030.

9

10 The 230kV transmission corridor between Richview TS and Manby TS is the main supply path for
11 the western half of the City of Toronto. It also supplies load in the southern Mississauga and
12 Oakville areas via Manby TS. The corridor has two 230kV double-circuit lines (R1K/R2K and
13 R13K/R15K) and one idle 115kV double-circuit line. The Toronto RIP and the IESO's Toronto
14 Integrated Regional Resource Plan (IRRP) identified the need to reinforce the transmission
15 system on the South-West GTA transmission corridor by rebuilding the existing idle 115kV
16 transmission line as a new 230kV double circuit line and connecting it to Manby TS and Richview
17 TS.

18

19 In Q4 2020 the IESO initiated a study addendum to the Toronto IRRP to explore the impact of
20 COVID-19 and energy efficiency programs on the timing of the need and preferred alternatives
21 for the investment. Completion of this Addendum is expected in Q3 2021. Hydro One's
22 expectation is that the study will confirm the planned date for the work.

23

24 Hydro One is obligated to provide facilities required to maintain the reliability and integrity of its
25 transmission system and reinforce or expand its transmission system as required to meet load
26 growth in accordance with its Transmission License and the Transmission System Code. Not
27 proceeding with this investment would result in Hydro One not meeting its obligation and not
28 addressing the need to provide adequate transmission capacity to supply load growth in the
29 South west GTA area. This investment is assigned a High Priority in order to meet this obligation.

1 **B. INVESTMENT DESCRIPTION**

2
3 The proposed project involves reinforcing the transmission system on South-West GTA
4 transmission corridor. Hydro One proposes to execute the project in two stages. Stage 1 will
5 address the line work and Stage 2 will address the station work in order to coordinate with
6 future 230kV breaker replacement work at Manby TS, as follows:

7
8 Stage 1: Line Work (Planned In-Service date is Q2 2025)

- 9
- 10 • Rebuild the existing 6.5 km idle 115kV double-circuit line as a 230kV double-circuit line;
 - 11 • Connect the new 230kV conductors in parallel with existing 230kV circuits (R2K and
12 R15K) at Richview TS and Manby TS; and
 - 13 • Modify the protection and control settings at Richview TS and Manby to incorporate the
14 new line.

15 Stage 2: Station Work (Planned In-Service date is Q2 2030)

- 16
- 17 • Remove the parallel connections made in Stage 1 and terminate the two new circuits
18 into Manby TS 230kV switchyard;
 - 19 • Connect new circuits at the Richview TS end to two of the existing 230kV transmission
20 circuits from Claireville TS to Richview TS; and
 - 21 • Add and/or modify protection and control equipment at Richview TS, Claireville TS and
22 Manby TS to incorporate the two new circuits.

23 A map showing the project location is provided below.

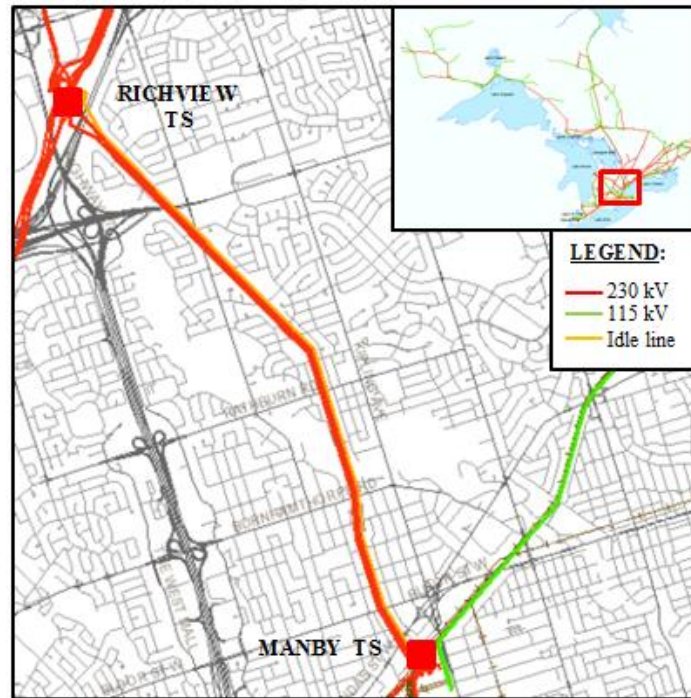

Figure 1: Map

1
2
3
4
5
6
7
8
9
10
11
12
13

Hydro One has initiated work under the Class Environmental Assessment process, as required under the Environmental Assessment Act, and approvals are expected to be obtained by Q3 2022.

Hydro One will apply for a “Leave to Construct” approval under Section 92 of the Ontario Energy Board Act in Q2 2022. A summary of the need, project description, risk, and costs have been presented herein; with specific details to be provided in the Section 92 application.

Hydro One studies show that the project will not adversely affect the reliability of the IESO-controlled grid or service to other transmission connected customers. The System Impact Assessment and Customer Impact Assessment have been completed.

1 **C. OUTCOMES**

2

3 This investment will provide the required increase in supply capacity to support future load
4 growth and maintain reliability for customers in Toronto and southern Mississauga/Oakville
5 areas.

6

7 **C.1 OEB RRF OUTCOMES**

8 The following table presents anticipated benefits as a result of the Investment in accordance
9 with the Ontario Energy Board’s (OEB) Renewed Regulatory Framework (RRF):

10

11 **Table 1 - Outcomes Summary**

Customer Focus	<ul style="list-style-type: none">• Ensure adequate supply capacity to support future load growth.
Operational Effectiveness	<ul style="list-style-type: none">• Increase operating flexibility of the transmission system by providing increase in transformation capacity.
Public Policy Responsiveness	<ul style="list-style-type: none">• Comply with Hydro One’s obligation under its Transmission License and the TSC to maintain the reliability and integrity of its transmission system and reinforce or expand its transmission system as required to meet load growth
Financial Performance	<ul style="list-style-type: none">• Costs are recovered from the network rate pool

12

13 **D. EXPENDITURE PLAN**

14

15 This investment is non-discretionary because it has been identified as the preferred investment
16 to address necessary transmission system reinforcement on the South-West GTA transmission
17 corridor. The project costs, as presented in the table below, will be recovered from the network
18 rate pool as these 230kV facilities are network assets and no capital contributions are required
19 from customers.

20

21 Table 2 below summarizes historical and projected spending on the aggregate investment level.
22 The “Previous Years” costs are the direct investment costs for investments noted above that
23 have incurred costs prior to the 2023 test year. Likewise, the costs noted in “Forecast 2028+”
24 are investment costs forecast beyond 2028.

1

Table 2 - Total Investment Cost

(\$ Millions)	Prev. Years	2023	2024	2025	2026	2027	Forecast 2028+	Total
Gross Investment Cost	6.1	6.5	7.5	3.0	0.0	1.0	18.5	42.6
Less Removals	0.0	0.0	0.0	0.0	0.0	0.0	0.0	0.0
Capital and Minor Fixed Assets	6.1	6.5	7.5	3.0	0.0	1.0	18.5	42.6
Less Capital Contributions	0.0	0.0	0.0	0.0	0.0	0.0	0.0	0.0
Net Investment Cost	6.1	6.5	7.5	3.0	0.0	1.0	18.5	42.6

2

3 **E. ALTERNATIVES**

4

5 Hydro One considered the following alternatives before selecting the preferred undertaking.

6

7 **ALTERNATIVE 1: STATUS QUO**

8 This investment is non-discretionary and is needed to ensure supply reliability for the customers
9 in Toronto and southern Mississauga/Oakville areas and support future load growth. The status
10 quo will not provide the necessary transmission system reinforcement on the South-West GTA
11 transmission corridor and is therefore not a viable alternative.

12

13 **ALTERNATIVE 2: UPGRADE THE TWO EXISTING DOUBLE CIRCUIT 230KV LINES**

14 Replace the existing conductor on the existing two double circuit 230kV transmission lines
15 R1K/R2K and R13K/R15K between Richview TS and Manby TS with higher current-rated
16 conductor.

17

18 **ALTERNATIVE 3 (RECOMMENDED): REPLACE EXISTING IDLE 115KV TRANSMISSION LINE WITH**
19 **NEW 230KV DOUBLE CIRCUIT TRANSMISSION LINE**

20 Rebuild the existing idle 115kV transmission line on the Richview to Manby transmission
21 corridor as a 230kV double circuit transmission line and connect at Manby TS and Richview TS.

1 **ALTERNATIVE 4: BUILD A NEW 230KV TRANSMISSION LINE BETWEEN OAKVILLE TS AND**
2 **TRAFALGAR TS**

3 Extend the existing 230kV transmission line between Cooksville TS and Oakville TS to Trafalgar
4 TS.

5
6 Alternative 2 provides lower supply reliability and construction will be very challenging because
7 of the difficulty in obtaining outages. Alternative 4 requires building a line on a new right-of-way
8 resulting in a higher cost. Alternative 3 is the lowest cost alternative, and maintains reliability
9 during the construction phase. Alternative 3 is therefore the recommended alternative. This is
10 in line with the recommended plan in the Metro Toronto Area Regional Infrastructure Plan

11

12 **F. EXECUTION RISK AND MITIGATION**

13

14 The risks in executing this investment are potential delays in securing the Section 92 and
15 environmental assessment approvals. These risks will be mitigated by initiating the Section 92
16 application process and environmental assessment process in a timely manner.

17

18 Normal project risks that may also affect the timely completion of the investment include the
19 availability of outages required for the work to be executed. These risks will be mitigated by
20 setting a schedule that aligns with outage availability.

1

This page left blank intentionally.

PROJECT SCHEDULE

1
2

TASK	START	FINISH
Section 92 Approval ¹	September 5, 2023	February 1, 2024
Receipt of Other Key Permits and Approvals ²	Jun-2022	Jan-2024
Detailed Engineering	Feb-2023	Dec-2023
Procurement	Jul-2023	Mar-2024
Receive Material	Jan-2024	May-2024
Construction	Feb-2024	Mar-2026
Commissioning	Oct-2025	Mar-2026
IN SERVICE³	N/A	Mar-2026
Site Remediation Completion	N/A	Nov-2026

3 The table above outlines the forecast schedule for the Project and has been predicated
 4 on securing leave to construct approval on or before February 1, 2024. Construction is set
 5 to commence in February 2024 and the cost evidence provided in **Exhibit B, Tab 7,**
 6 **Schedule 1** is underpinned by this schedule. As identified **Exhibit B, Tab 7, Schedule**

¹ This review time is predicated on the OEB Performance Standards for Processing Leave to Construct Applications and assumes a written hearing review of this Application. However, Hydro One is hopeful that regulatory efficiencies can be obtained in the review of this Application and this Application will be disposed of without a hearing for the reasons articulated in **Exhibit B, Tab 1, Schedule 1**.

² Key Permits: As documented, the final ESR for the Project was submitted to MECP on June 5, 2023. Additional permits that will need to be acquired include Municipal Permits (Encroachment, Access), Ministry of Transportation (MTO) Encroachment Permits, Nav Canada Land Use Assessment and other environmental permits (Tree Preservation, Safe Harbors, etc).

³ The in-service date specified is in reference to the 230 kV double-circuit transmission line from Richview TS to Manby TS. The re-stringing of the 230 kV transmission line K21C from Manby TS to Cooksville TS to increase the overhead line ampacity as per the SIA, is planned for completion in May 2026.

1 **1**, delays in regulatory approvals beyond those contemplated in the project schedule
2 documented above could materially impact the cost of the Project. Contingency has been
3 carried on the Project to account for minor deviations to this schedule, however, material
4 delays in securing approvals could have significant impacts that have not been carried in
5 contingency based on recent OEB leave to construct processing timelines and taking into
6 consideration the OEB's Performance Standards for Processing Leave to Construct
7 Applications.

DESCRIPTIONS OF THE PHYSICAL DESIGN

1.0 ROUTE DESCRIPTION

The 230 kV transmission corridor between Richview TS and Manby TS in Etobicoke is the main supply path for the western half of the City of Toronto. Currently there are two 230 kV double-circuit transmission lines (R1K/R2K and R13K/R15K) and one idle 115 kV double-circuit transmission line (K9S/K10SB) along this corridor. Together with the other 230 kV circuit R24C between Richview TS and Cooksville TS, this corridor also supplies the load in the southern Mississauga and Oakville areas via Manby TS.

The new line will be built in place of the existing idle 115 kV double-circuit transmission line on the east side of the existing corridor and will be connected at Richview TS and Manby TS by sharing the existing terminations for the 230 kV circuit R15K.

In this initial phase of the Project, the new 230 kV double-circuit transmission line will have its conductors paralleled to become the R15K super circuit and connected to the existing R15K termination at Richview TS and Manby TS. The existing R15K on the R13K/R15K towerline will be redesignated as R1K and connected to the existing R1K termination at Richview TS and Manby TS. Similarly, the existing 230 kV double-circuit transmission line (R1K/R2K), on the west side of the corridor, will have its conductors paralleled to become the R2K super circuit and connected to the existing R2K termination at Richview TS and Manby TS.

Additionally, two spans on the 230 kV transmission line K21C from Manby TS to Cooksville TS will be re-strung to increase the overhead line ampacity, as per the SIA. The rating of the underground section of the line will remain as is.

1.1 ROUTE DETAILS

- i. The Project will use and replace an existing, idle 115 kV double-circuit transmission line.

- 1 ii. The Project route starts at Richview TS, located adjacent to Hwy 401 in
2 Etobicoke, ON. The line exits south-east from the station and heads south along
3 the existing transmission corridor for approximately 6.5 km towards Manby TS.
4

5 A map showing the general route of the Project is provided as **Attachment 1 of Exhibit**
6 **B, Tab 2, Schedule 1.**
7

8 **2.0 LINE DESCRIPTION**

9 The proposed 230 kV double-circuit transmission line will have two (2) circuits comprised
10 of one 1780 kcmil ACSR/TW “Chukar” conductor per phase and three 19#8 Alumoweld
11 shield wires, primarily supported on self-supporting lattice towers. Further, the
12 transmission line will have the following attributes:

- 13 i. Each circuit on the new towerline will have a continuous ampacity of 1290A, and
14 an LTE rating of 1700A;
- 15 • In the super circuit configuration, the new line will have continuous and
16 LTE ratings of 2580A and 3400A, respectively.
- 17 ii. At Richview TS and Manby TS, the R2K and R15K super circuits will be strung
18 with twin bundle 1443.7 kcmil ACSR/TW conductors before the phases on the
19 mainline are tied together in super circuit configuration.
- 20 • For these spans, the continuous ampacity will be 2320A, and have a
21 LTE rating of 3060A.
- 22 iii. Glass insulators will be used for both suspension and dead end applications;
- 23 iv. Stockbridge-type vibration dampers to dampen the conductors and shieldwires;
- 24 v. Typical structure foundations will be concrete augur footings, while some
25 structures will be supported by micro pile and helical pile foundations;
- 26 vi. The line will make use of 27 self-supported towers. There will also be some new
27 tapping structures at both Richview TS and Manby TS.
- 28 vii. Structures to be used in the proposed line are X10S, X10S Narrow Base, X10M,
29 X10M Narrow Base, X10H and X14M (1-Steel Pole) type towers. See Figure 1
30 below.

- 1 viii. New structures will be bonded to existing adjacent structures of the other 230 kV
 2 transmission lines to improve grounding in the corridor.
 3
 4
 5
 6

Figure 1: Tower Types

X10S Tower Type

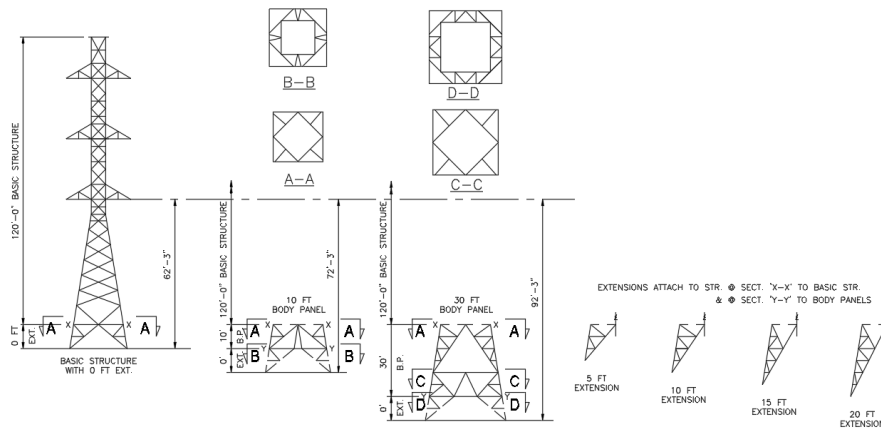

X10S Narrow Base Tower Type

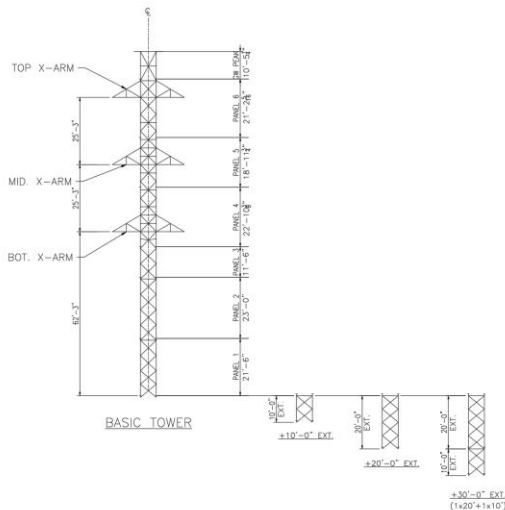

1

X10H Tower Type

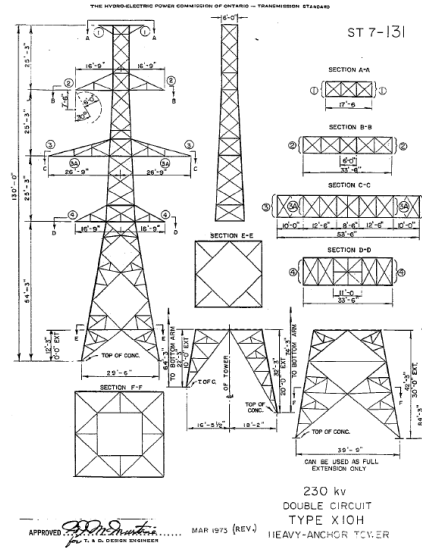

X14M (1 Single Pole) Tower Type

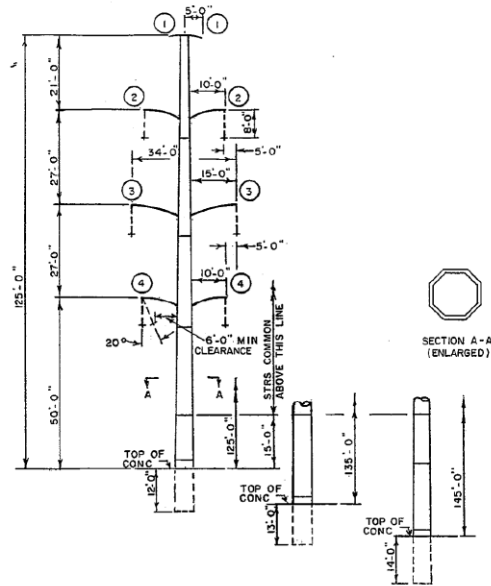

2

3 In accordance with the SIA, the following works will also be undertaken:

- 4 i. At Manby TS, on the first 230 kV circuit K21C span from the gantry structure to
- 5 Structure 28 will be restrung with twin bundle 1443.7 kcmil ACSR/TW conductor,
- 6 replacing the existing single 1843 kcmil ACSR.

- 1 ii. At Applewood JCT, on the 230 kV circuit K21C span from Structure 1 to the
2 BPEX pothead structures will be restrung with twin bundle 1443.7 kcmil
3 ACSR/TW conductor, replacing the existing span of single 1843 kcmil ACSR and
4 1780 kcmil ACSR/TW jumper at the pothead structure.

5

6 Lastly, the line work will also include a re-tap of Horner TS from R13K to R15K as shown
7 in the schematic diagram provided in **Exhibit B, Tab 2, Schedule 1, Attachment 2**.

8

9 **3.0 LINE REMOVAL**

10 As described, the Project will make use of an existing corridor and centerline of an
11 existing idle 115 kV double-circuit transmission line. The existing towers will be removed
12 as part of this Project. During stringing of the new 230 kV double-circuit transmission
13 line, the conductors will be transferred to temporary wood pole structures.

14

15 **4.0 STATION WORK**

16 In conjunction with the line facilities work described above, the Project will require minor
17 station related work indicated below:

18

- 19 • Richview TS

20 Project work at this station consists of modifying the R2K, R15K 'A' and 'B' line
21 protection settings based on the new bundled line impedances. In addition, revising
22 the R15K and R13K line relay settings and logic are required due to Horner TS re-
23 tap from R13K to R15K.

24

- 25 • Manby TS

26 Project work at this station consists of modifying the R2K, R15K 'A' and 'B' line
27 protection settings based on the new bundled line impedances. In addition, revising
28 the R15K and R13K line relay settings and logic are required due to Horner TS re-
29 tap from R13K to R15K. The re-tap of Horner onto R15K from R13K will require
30 existing NSD570 links between Horner TS and Manby TS reconfiguration.

OPERATIONAL DETAILS

1
2
3
4
5
6
7
8
9
10
11
12
13
14
15

The Project will replace an existing, idle 115 kV double-circuit transmission line with a new 230 kV double-circuit transmission line approximately 6.5 km long. The 230 kV circuits R2K and R15K will be “super circuits” between Richview TS and Manby TS.

Upon completion of the Project, Horner TS will be supplied by 230 kV circuits R2K and R15K. This improves the overall transfer capability of the interface.

The upgrade at Applewood JCT will increase the thermal capability of 230 kV circuit K21C. The need for this upgrade was identified in the IESO’s SIA and it will improve the transfer capability between Richview TS and Manby TS following certain contingencies.

Operation of the proposed facilities will continue to be in accordance with the procedures of Hydro One’s ISOC as directed by the IESO.

This page has been left blank intentionally.

LAND MATTERS

1.0 DESCRIPTION OF LAND RIGHTS

As referenced in the Application, through the Etobicoke Greenway Project, Hydro One is proposing to rebuild the existing 6.5 km idle 115 kV double-circuit transmission line as a 230 kV double-circuit transmission line. The Project will involve line work on the idle 115 kV transmission line between Richview TS and Manby TS, located in the municipality of Toronto. The width of the existing ROW is up to 120 meters wide and will provide sufficient width for the proposed work. Consequently, no new property right acquisitions are contemplated by this Project as of the filing of this Application.

The existing transmission corridor is exclusively situated on Bill 58 lands, lands owned by the Province of Ontario over which Hydro One holds a statutory easement, except for, where necessary, crossing perpendicularly over public roads or railways. In those instances, Hydro One will occupy within public road allowances and exercise legislated occupation rights pursuant to section 41 of the *Electricity Act* or existing rail crossings. The proposed transmission Project, therefore, is not expected to have a material impact on the rights of adjacent properties and will rely on existing occupational rights that currently exist to effectuate construction.

The relative land ownership type proportions specific to the properties affected are as follows:

Land Ownership Type	Area (Hectares)	Proportion of Route (%)
Bill 58 (Infrastructure Ontario) Lands	18.9	88%
Road Allowance	2.5	11.6%
Other (rail)	0.09	0.4%

The Project's upgraded transmission line will be all above ground and will, for all sections, be constructed to account for the routes' topography and associated land profiles,

1 ensuring the Project meets Hydro One's minimum line clearances designed for the
2 Project's selected conductor sizing.

3
4 As study of the Project has progressed, Hydro One has become aware of various
5 encroachments along Hydro One's corridor, e.g., vegetable gardens, fences, etc. As
6 necessary, these encroachments will be addressed as the Project proceeds and Hydro
7 One is informing the OEB of this activity, however, no new rights are contemplated or
8 necessary to exercise Hydro One's statutory rights in this corridor.

9 10 **2.0 MAPS OF THE PROJECT AREA**

11 At **Exhibit B, Tab 2, Schedule 1, Attachment 1**, Hydro One has provided a map with the
12 intention it be used as the Application's *Notice Map* should the OEB determine that a
13 hearing is required. **Attachment 1 of this Schedule** provides a more detailed route map
14 that illustrates, as appropriate, property along line route sections with PIN numbers¹ of the
15 land over, under, on or adjacent to which the line runs. As illustrated therein, and detailed
16 in this Schedule, the route runs adjacent to properties but no property rights from those
17 adjacent properties are required to deliver the Project and thus these lands will not be
18 directly affected by the Project.

19 20 **3.0 DESCRIPTION OF NEW LAND RIGHTS REQUIRED**

21 As aforementioned, no new land rights are required therefore this section of evidence is
22 not applicable to this filing.

23 24 **4.0 EARLY ACCESS TO LAND**

25 The final ESR has been completed and the corridor is exclusively situated on Bill 58 lands.
26 As a result, no early access to land information is necessary for the purposes of this filing.

¹ PIN numbers have been provided and can be reasonably utilized to validate lot and concession numbers as may be necessary for the purposes of this proceeding.

1 **5.0 LAND ACQUISITION PROCESS**

2 As aforementioned, there will be no acquisition of new land rights required to deliver the
3 Project therefore this section of evidence is not applicable to this filing.

4

5 **6.0 LAND - RELATED FORMS**

6 As aforementioned, there will be no acquisition of new land rights required to deliver the
7 Project therefore this section of evidence is not applicable to this filing.

This page has been left blank intentionally.

Routing Maps

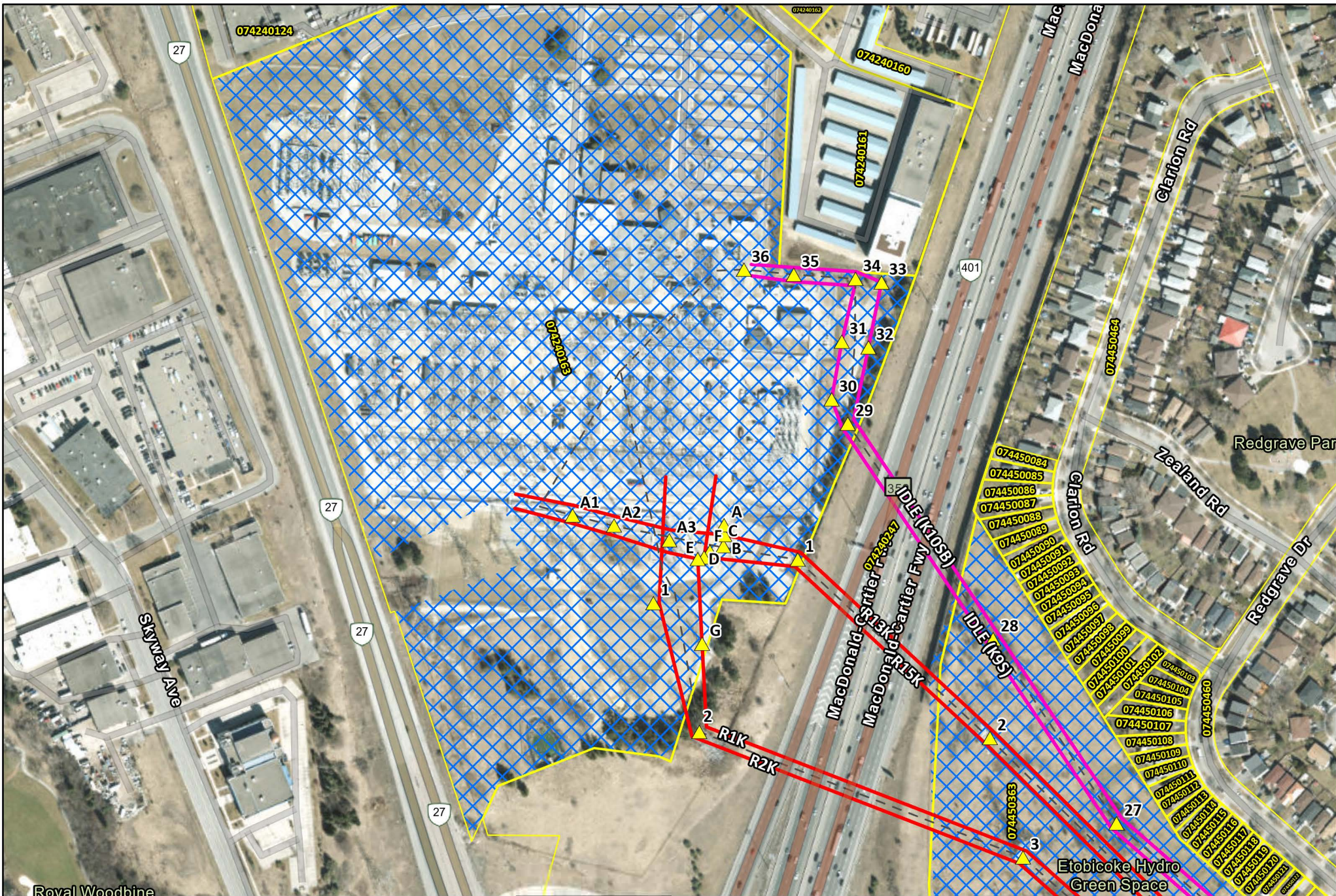

Circuit

- IDLE
- LIVE

Real Estate Rights

- ⊗ Easement
- ⊗ Purchased/Bill 58

Centreline

- ▲ Structure
- Property Boundary

Richview x Manby

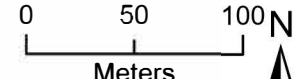

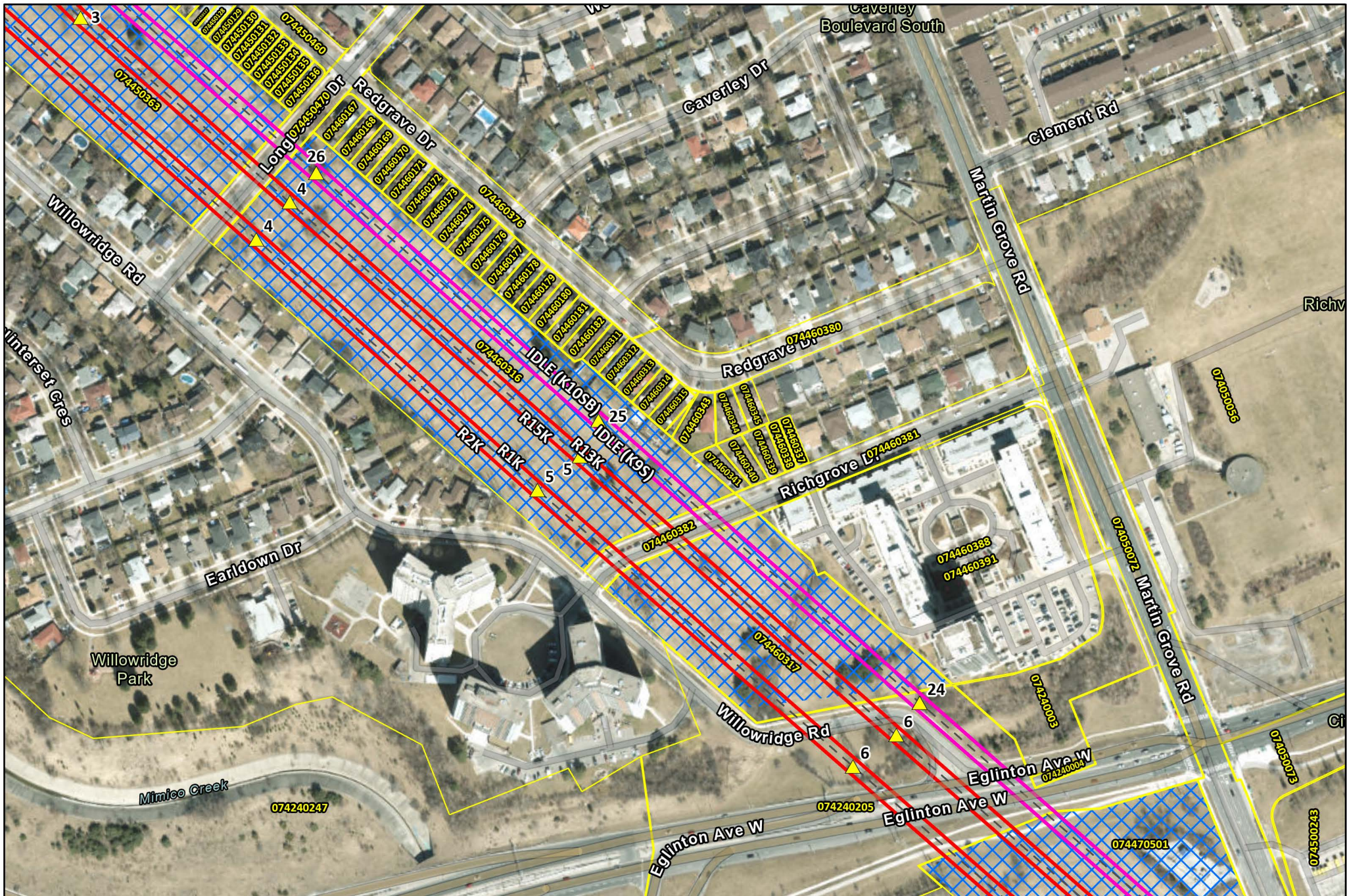

Created by: BB Created on: July 27, 2023

This map is created from a subset of data from a variety of government and organization databases and websites. LandSolutions makes no claims, representations, nor warranties, express or implied, concerning the validity, reliability or accuracy of the GIS data and GIS data products provided by LandSolutions, including the implied validity of any uses of such data



Circuit

- IDLE
- LIVE

Real Estate Rights

- ⊗ Easement
- ⊗ Purchased/Bill 58

--- Centreline

- ▲ Structure
- Property Boundary

Richview x Manby

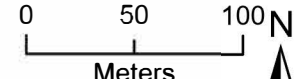

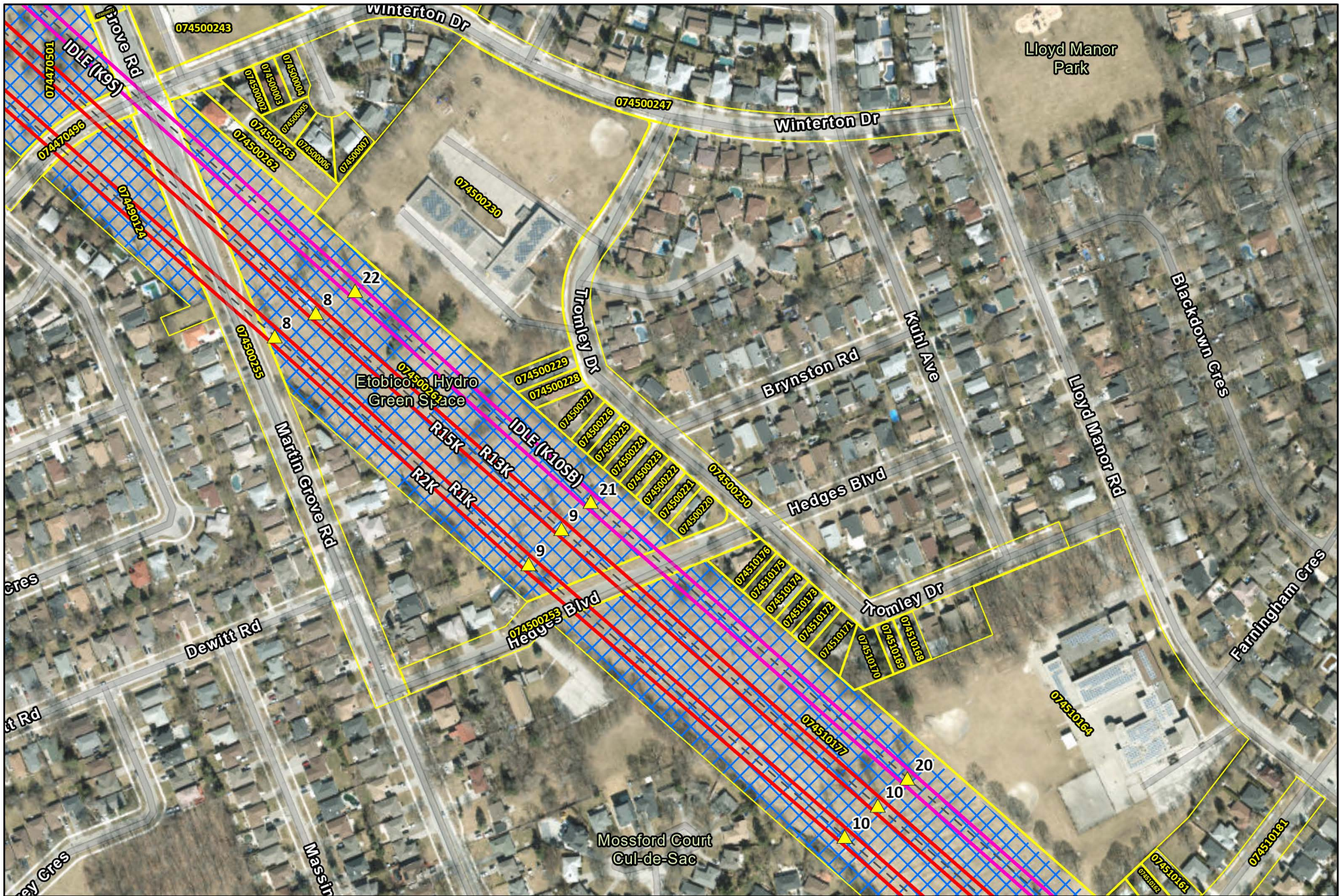

Created by: BB Created on: July 27, 2023

This map is created from a subset of data from a variety of government and organization databases and websites. LandSolutions makes no claims, representations, nor warranties, express or implied, concerning the validity, reliability or accuracy of the GIS data and GIS data products provided by LandSolutions, including the implied validity of any uses of such data



Circuit

- IDLE
- LIVE

Real Estate Rights

- ⊗ Easement
- ⊗ Purchased/Bill 58

--- Centreline

- ▲ Structure
- Property Boundary

Richview x Manby

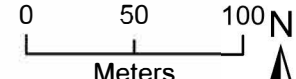

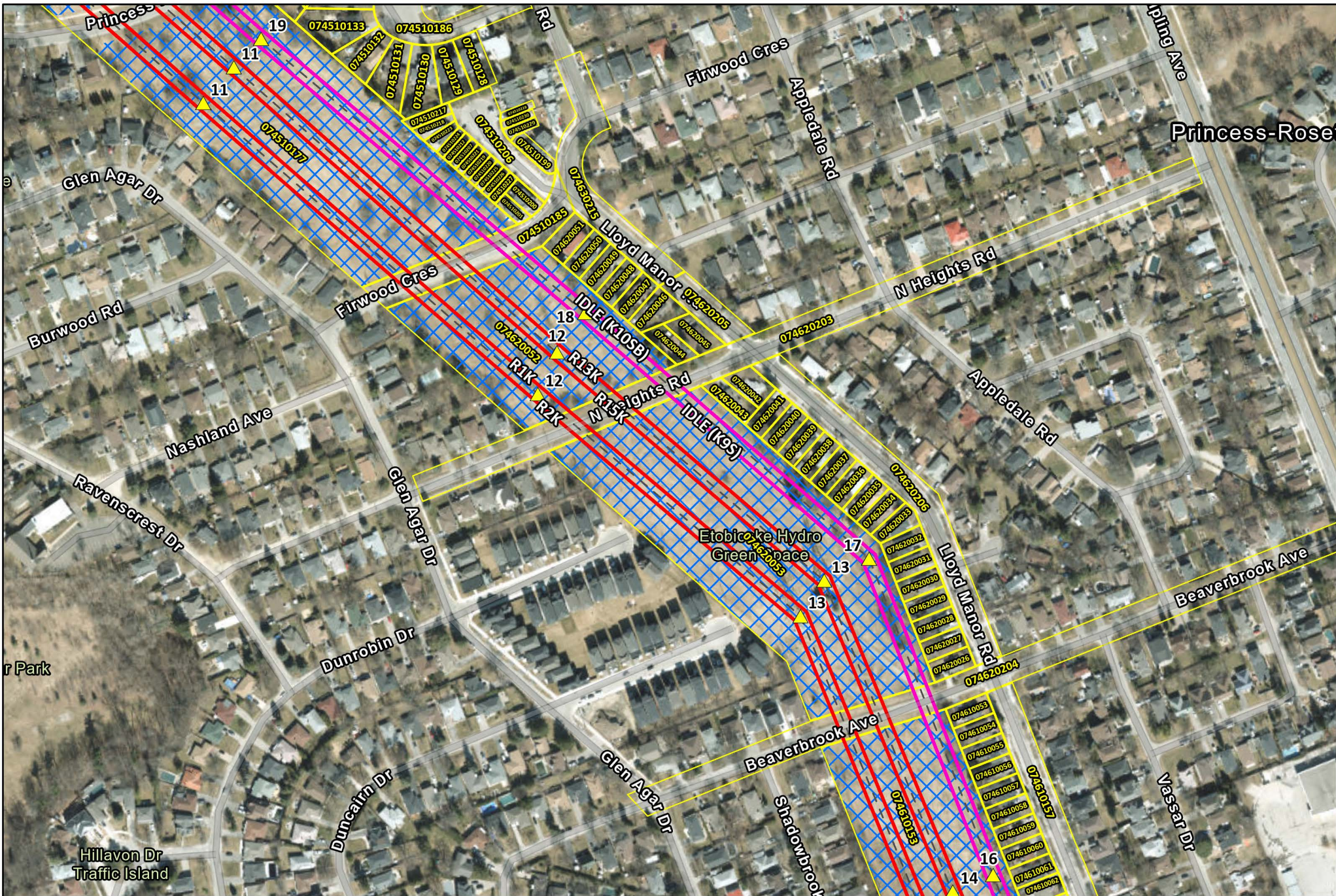

Created by: BB Created on: July 27, 2023

This map is created from a subset of data from a variety of government and organization databases and websites. LandSolutions makes no claims, representations, nor warranties, express or implied, concerning the validity, reliability or accuracy of the GIS data and GIS data products provided by LandSolutions, including the implied validity of any uses of such data



Circuit

- IDLE
- LIVE

Real Estate Rights

- X Easement
- X Purchased/Bill 58

--- Centreline

- ▲ Structure
- Property Boundary

Richview x Manby

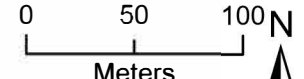

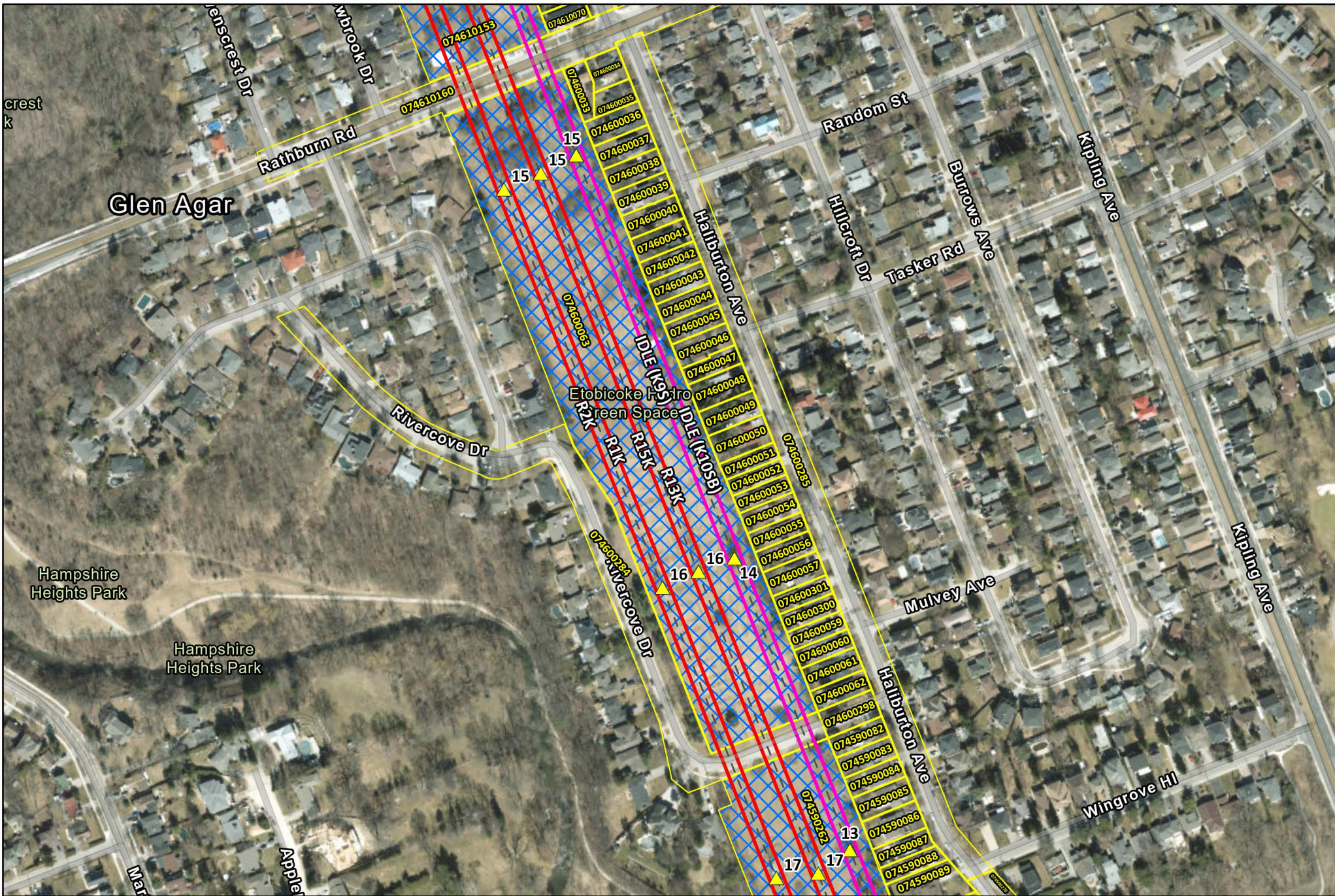

Created by: BB Created on: July 27, 2023

This map is created from a subset of data from a variety of government and organization databases and websites. LandSolutions makes no claims, representations, nor warranties, express or implied, concerning the validity, reliability or accuracy of the GIS data and GIS data products provided by LandSolutions, including the implied validity of any uses of such data



Circuit

- IDLE
- LIVE

Real Estate Rights

- ⊗ Easement
- ⊗ Purchased/Bill 58

--- Centreline

- ▲ Structure
- Property Boundary

Richview x Manby

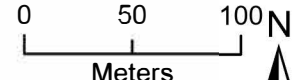

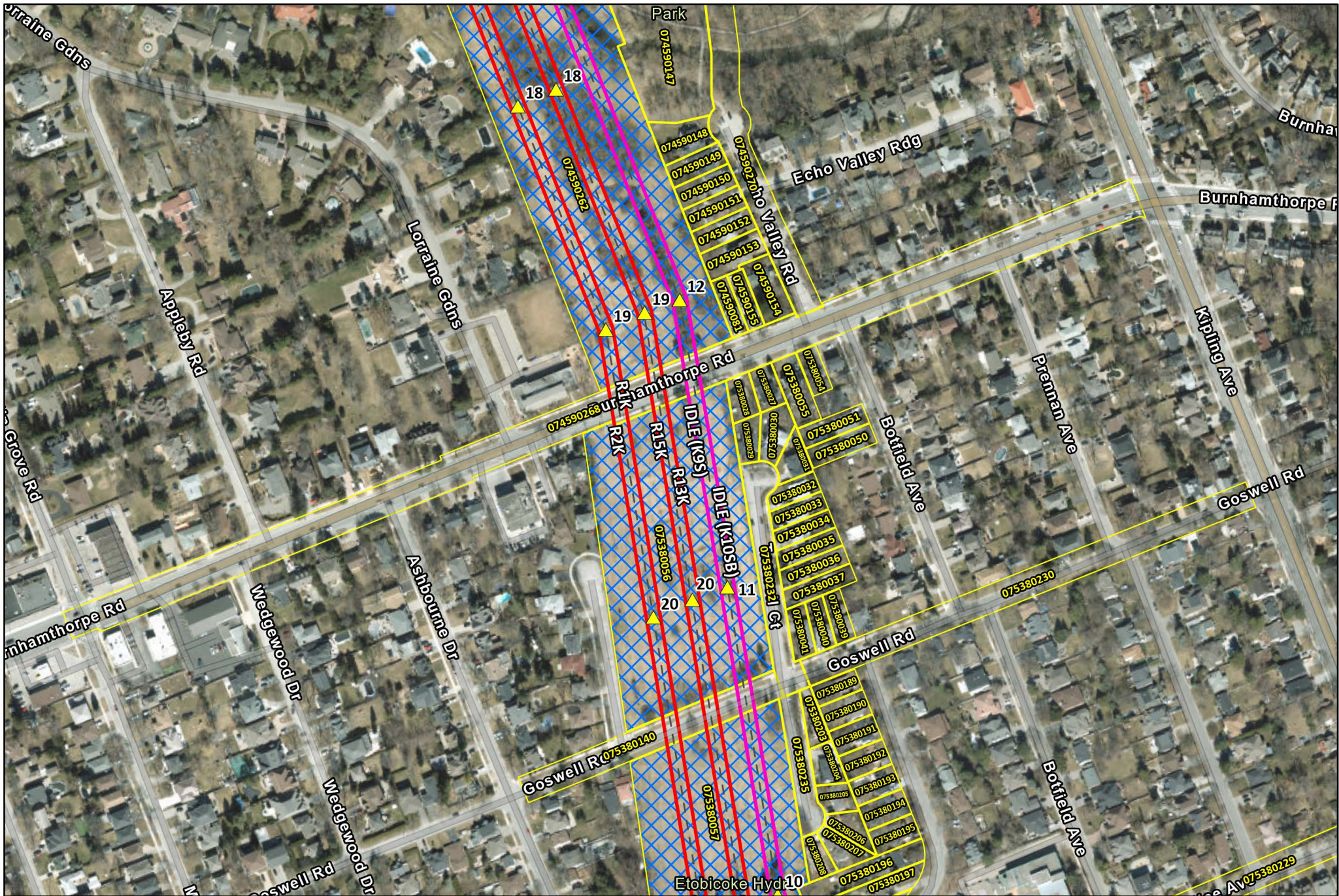



 Created by: BB Created on: July 27, 2023

This map is created from a subset of data from a variety of government and organization databases and websites. LandSolutions makes no claims, representations, nor warranties, express or implied, concerning the validity, reliability or accuracy of the GIS data and GIS data products provided by LandSolutions, including the implied validity of any uses of such data.





Circuit

- IDLE
- LIVE

Real Estate Rights

-  Easement
-  Purchased/Bill 58

- - - Centreline
 Structure
 Property Boundary

Richview x Manby

0 50 100 N

Meters

Page 7 of 9 Scale: 1:3,500



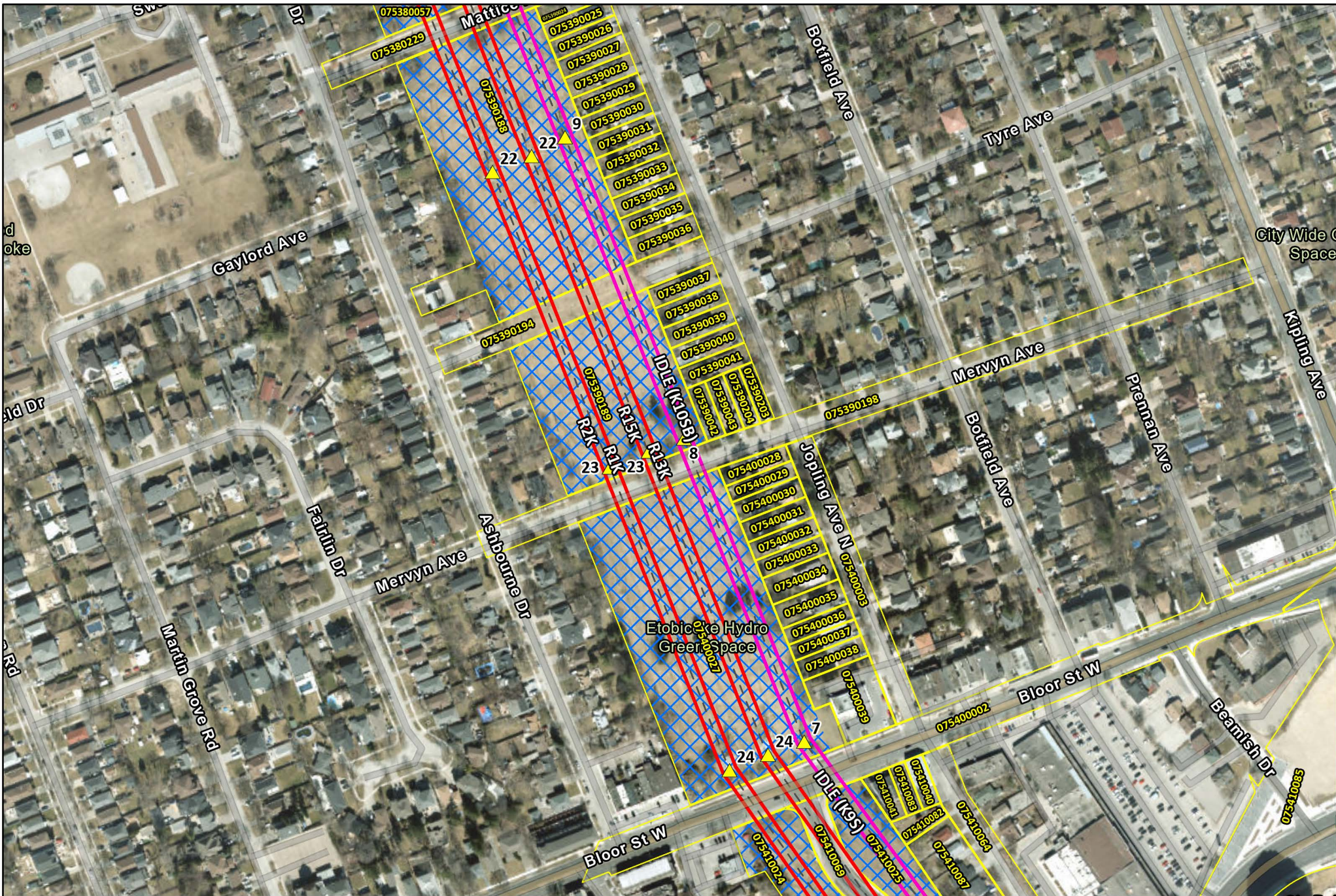

Created by: BB Created on: July 27, 2023

This map is created from a subset of data from a variety of government and organization databases and websites. LandSolutions makes no claims, representations, nor warranties, express or implied, concerning the validity, reliability or accuracy of the GIS data and GIS data products provided by LandSolutions, including the implied validity of any uses of such data



Circuit

- IDLE
- LIVE

Real Estate Rights

- ⊗ Easement
- ⊗ Purchased/Bill 58

--- Centreline

- ▲ Structure
- Property Boundary

Richview x Manby

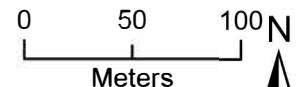

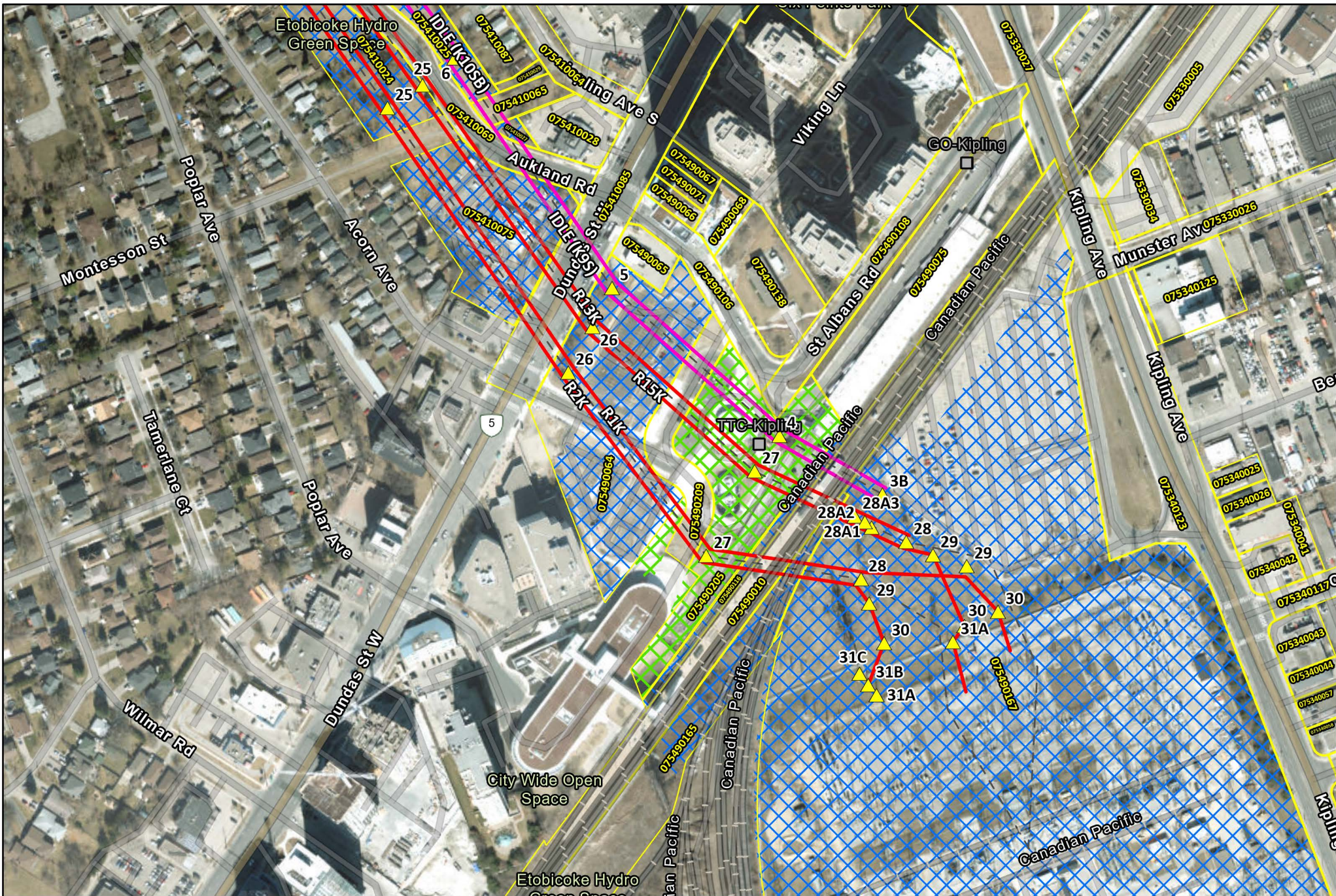

- IDLE
- LIVE

- ▨ Easement
- ▨ Purchased/Bill 58

- ▲ Structure
- Property Boundary

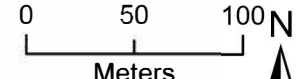

SYSTEM IMPACT ASSESSMENT

1
2
3
4
5
6
7
8
9
10
11

Please refer to **Attachment 1** for the Final SIA prepared by the IESO (SIA reference # CAA 2018-637).

The SIA concludes that the proposed connection of the project is expected to have no material adverse impact on the reliability of the integrated power system, provided that all requirements in this report are implemented.

Hydro One confirms that it will implement the requirements noted by the IESO in the SIA.

This page has been left blank intentionally.



System Impact Assessment Report

Final Report - Public

CAA ID: 2018-637

Project: Richview TS to Manby TS Transmission
Reinforcement

Connection Applicant: Hydro One Networks Inc.

February 26, 2021



Acknowledgement

The IESO wishes to acknowledge the assistance of Hydro One in completing this assessment.

Disclaimers

IESO

This report has been prepared solely for the purpose of assessing whether the connection applicant's proposed connection with the IESO-controlled grid would have an adverse impact on the reliability of the integrated power system and whether the IESO should issue a notice of conditional approval or disapproval of the proposed connection under Chapter 4, section 6 of the Market Rules.

Conditional approval of the project is based on information provided to the IESO by the connection applicant and Hydro One at the time the assessment was carried out. The IESO assumes no responsibility for the accuracy or completeness of such information, including the results of studies carried out by Hydro One at the request of the IESO. Furthermore, the conditional approval is subject to further consideration due to changes to this information, or to additional information that may become available after the conditional approval has been granted.

If the connection applicant has engaged a consultant to perform connection assessment studies, the connection applicant acknowledges that the IESO will be relying on such studies in conducting its assessment and that the IESO assumes no responsibility for the accuracy or completeness of such studies including, without limitation, any changes to IESO base case models made by the consultant. The IESO reserves the right to repeat any or all connection studies performed by the consultant if necessary to meet IESO requirements.

Conditional approval of the proposed connection means that there are no significant reliability issues or concerns that would prevent connection of the proposed project to the IESO-controlled grid. However, the conditional approval does not ensure that a project will meet all connection requirements. In addition, further issues or concerns may be identified by the transmitter(s) during the detailed design phase that may require changes to equipment characteristics and/or configuration to ensure compliance with physical or equipment limitations, or with the Transmission System Code, before connection can be made.

This report has not been prepared for any other purpose and should not be used or relied upon by any person for another purpose. This report has been prepared solely for use by the connection applicant and the IESO in accordance with Chapter 4, section 6 of the Market Rules. This report does not in any way constitute an endorsement of the proposed connection for the purposes of obtaining a contract with the IESO for the procurement of supply, generation, demand response, demand management or ancillary services.

The IESO assumes no responsibility to any third party for any use, which it makes of this report. Any liability which the IESO may have to the connection applicant in respect of this report is governed by Chapter 1, section 13 of the Market Rules. In the event that the IESO provides a draft of this report to the connection applicant, the connection applicant must be aware that the IESO may revise drafts of this report at any time in its sole discretion without notice to the connection applicant. Although the IESO will use its best efforts to advise you of any such changes, it is the responsibility of the connection applicant to ensure that the most recent version of this report is being used.

Hydro One

The results reported in this report are based on the information available to Hydro One, at the time of the study, suitable for a System Impact Assessment of this connection proposal.

The short circuit and thermal loading levels have been computed based on the information available at the time of the study. These levels may be higher or lower if the connection information changes as a result of, but not limited to, subsequent design modifications or when more accurate test measurement data is available.

This study does not assess the short circuit or thermal loading impact of the proposed facilities on load and generation customers.

In this report, short circuit adequacy is assessed only for Hydro One circuit breakers. The short circuit results are only for the purpose of assessing the capabilities of existing Hydro One circuit breakers and identifying upgrades required to incorporate the proposed facilities. These results should not be used in the design and engineering of any new or existing facilities. The necessary data will be provided by Hydro One and discussed with any connection applicant upon request.

The ampacity ratings of Hydro One facilities are established based on assumptions used in Hydro One for power system planning studies. The actual ampacity ratings during operations may be determined in real-time and are based on actual system conditions, including ambient temperature, wind speed and facility loading, and may be higher or lower than those stated in this study.

The additional facilities or upgrades which are required to incorporate the proposed facilities have been identified to the extent permitted by a System Impact Assessment under the current IESO Connection Assessment and Approval process. Additional facility studies may be necessary to confirm constructability and the time required for construction. Further studies at more advanced stages of the project development may identify additional facilities that need to be provided or that require upgrading.



Table of Contents

Acknowledgement	1
Disclaimers	2
IESO	2
Hydro One	3
Project Description	7
Notice of Conditional Approval	10
Assessment Findings	10
IESO Requirements for Connection	12
Connection Applicant Requirements	12
Appendix A: General Requirements	13



List of Figures

Figure 1:Existing and Proposed Phase 1 Transmission Circuits Between Manby TS and Richview TS	8
Figure 2:Phase 2 Revised Bus Configuration of Manby East TS and Manby West TS	9
Figure 3:Proposed Phase 2 Transmission Circuits Between Manby TS and Richview TS	9



List of Tables

No table of figures entries found.

Project Description

Hydro One Inc. (the “connection applicant” and “transmitter”) is proposing to rebuild the existing idle 115kV line between Richview TS and Manby TS into two new 230kV circuits (the “project”). This is to relieve the forecasted thermal overloading on the 230 kV transmission lines in the corridor between Manby TS and Richview TS, and to supply the load in both the western part of Metro Toronto and the stations west of Cooksville. The need to increase the transfer capability between Richview TS and Manby TS was identified in the 2019 Central Toronto Area Integrated Regional Resource Plan (IRRP) report and is being studied as part of the ongoing Toronto IRRP Addendum.

The project consists of two phases which are illustrated in Figure 1 to Figure 3:

Phase 1:

- The existing idle 115kV line between Richview TS and Manby TS will be rebuilt into two new 230kV circuits, which are then bundled into one super-circuit. The new 230 kV super-circuit will take the breaker positions of the existing circuit R15K at both ends and be designated as circuit R15K.
- The existing circuit R15K will be re-connected at both ends, taking the breaker positions of the existing circuit R1K and renamed R1K.
- The existing R1K and R2K circuits will be bundled as one new super-circuit R2K, taking the breaker positions of the existing R2K at both ends.
- The Horner TS tap point on the existing R13K circuit will be moved onto the new circuit R15K.
- Zone 1 protection of super-circuit lines R2K and R15K will be disabled while zone 2 will be retained as zone 1 protections will not be accurate for these short lines.
- The existing last section of K21C of 9 meters connected to Cooksville TS will be upgraded. The long-term thermal rating of the new line section will be at least 2000 Amps.

Phase 2:

- The super-circuits R2K and R15K will be unbundled such that there will be six 230 kV circuits in the corridor between Manby TS and Richview TS.
- Three new 230 kV circuit breakers will be added at Manby East TS and Manby West TS to allow for the termination of the two new additional 230 kV circuits.
- One circuit from the unbundled super-circuit R2K will remain as circuit R2K, and the other circuit will take the connection positions of phase 1 circuit R1K at both ends and be designated as new circuit R1K.
- Phase 1 circuit R1K will be re-terminated to the switchyard of Manby West TS at one end and the other end will tap onto circuit V79R near Richview TS, and the circuit between Claireville TS, Richview TS, and Manby West TS will be renamed V79RK.

- One circuit of the unbundled super-circuit R15K will remain as circuit R15K, and the other circuit will be terminated to the switchyard of Manby East TS at one end and the other end will tap onto circuit V73R near Richview TS, and the circuit between Claireville TS, Richview TS, and Manby East TS will be renamed V73RK.
- The Horner TS tap point on phase 1 circuit R15K will be moved onto circuit R13K.
- Zone 1 protection for super-circuits R2K and R15K, that was disabled in phase 1, will be reinstated.
- The 230 kV circuits between Claireville TS, Richview TS, and Manby TS, i.e. V73RK and V79RK, will be protected by three terminal DCB protections.

This configuration allows Richview TS to be bypassed to provide a continuous supply to Manby TS in case there is an emergency in Richview TS.

Figure 3 shows the proposed phase 2 transmission circuits between Manby TS and Richview TS.

The proposed in-service dates of the project's phase 1 and phase 2 are Q1, 2023 and Q4, 2025, respectively.

Figure 1: Existing and Proposed Phase 1 Transmission Circuits Between Manby TS and Richview TS

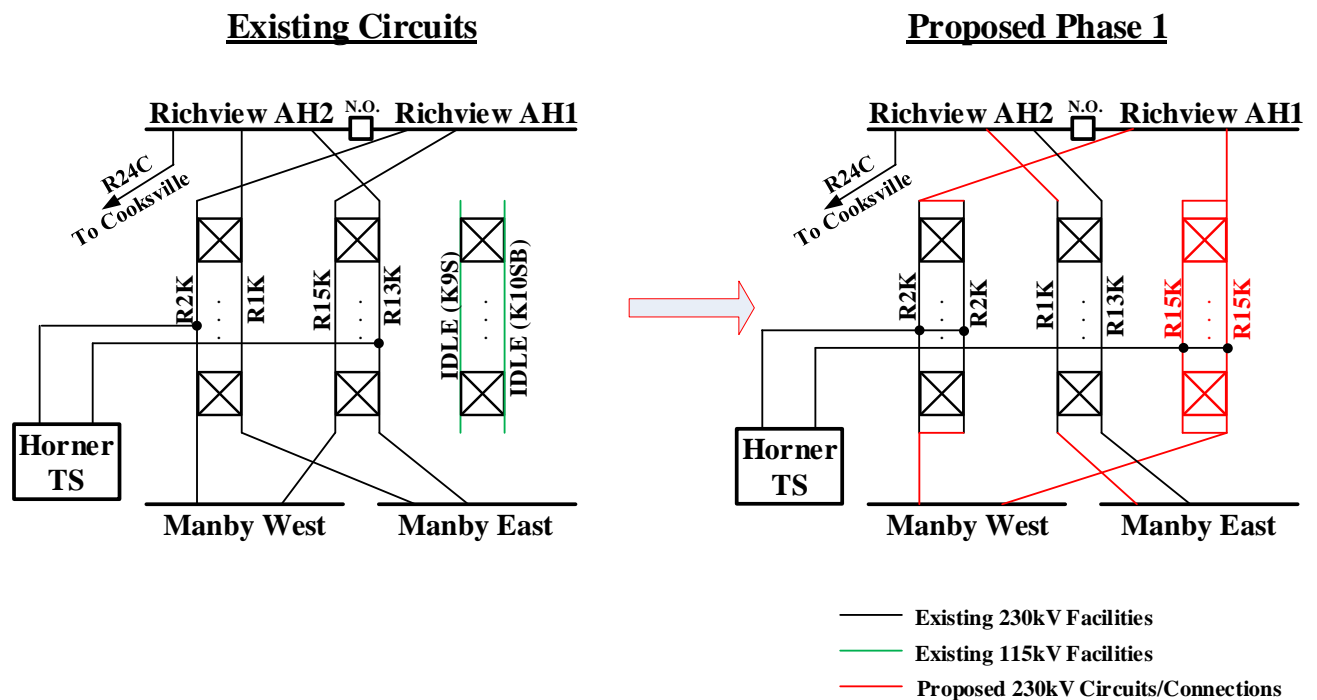
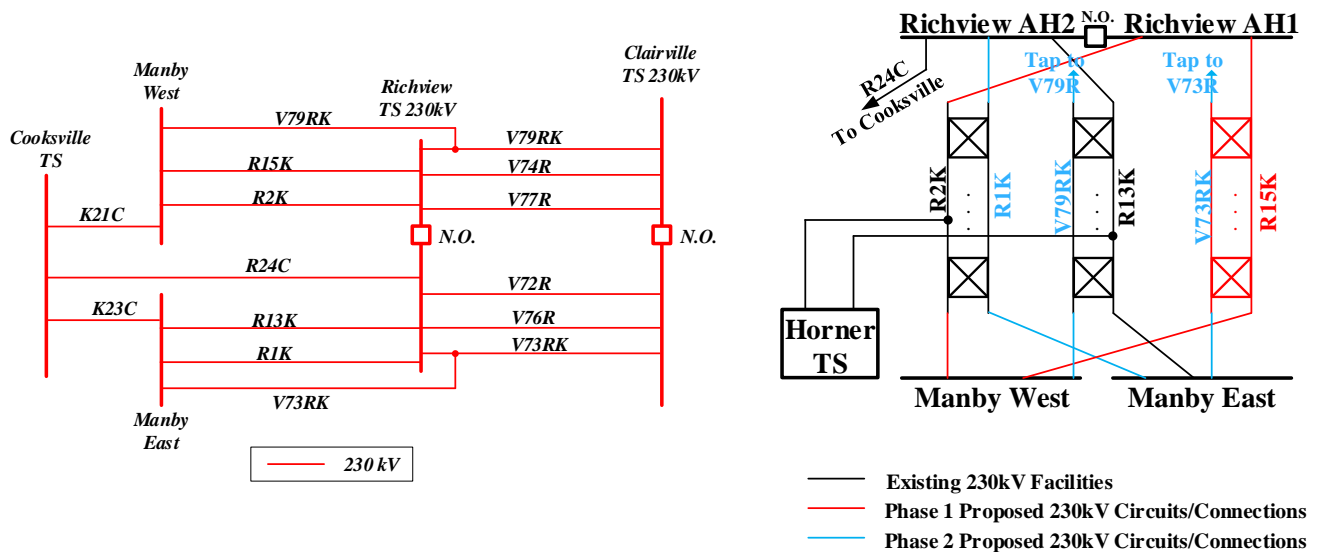

Figure 2:Phase 2 Revised Bus Configuration of Manby East TS and Manby West TS



Figure 3:Proposed Phase 2 Transmission Circuits Between Manby TS and Richview TS

Proposed Phase 2



Notice of Conditional Approval

This assessment concludes that the proposed connection of the project is expected to have no material adverse impact on the reliability of the integrated power system, provided that all requirements in this report are implemented. Therefore, the assessment supports the release of the Notification of Conditional Approval for connection of the project.

Assessment Findings

1. After the project is in-service, pre-contingency actions are no longer needed to accommodate 230 kV circuit outages; with the current system configuration, an outage to one 230 kV circuit would require load supplied by Manby East TS and Manby West TS to be transferred or curtailed.
2. The proposed protection changes for both phase 1 and phase 2 will have no material adverse impact on the IESO-controlled grid in terms of transient stability.
3. New contingencies are created due to the incorporation of the project as follows:
 - a. For phase 1 of the project, circuits R1K and R13K are sharing the same towers for more than 5 towers; therefore, the new double contingency of R1K+R13K is created. The double contingencies of R1K+R2K and R13K+R15K will no longer exist.
 - b. For phase 2 of the project, circuits R13K and V79RK; R15K and V73RK; R1K and R2K; are each sharing the same towers for more than 5 towers; therefore, the new double contingencies of R13K+V79RK, R15K + V73RK, and R1K+R2K are created.
 - c. For phase 2 of the project, there are new combinations of circuits and transformers that are tripped as a result of new Manby East TS and Manby West TS breaker failure contingencies.
4.
 - a. For phase 1 of the project, the post-contingency flow on the section of circuit K21C between Applewood Junction and Cooksville TS exceeds the long-term emergency (LTE) ratings, but is within the short-term emergency (STE) ratings following (i) the double contingency R1K+R13K when the 230 KV circuit R24C is out-of-service and (ii) the contingency of Richview TS A2L24 breaker failure when the 230 kV circuit R13K is out-of-service.
 - b. For phase 1 of the project, the post-contingency flow on the section of circuit R24C between Applewood Junction and Cooksville TS and the section of circuit V72R between Richview DESN and Claireville TS exceeds the LTE ratings, but is within the STE ratings following the double contingency R1K+R13K when the 230 KV circuit K21C is out-of-service.
 - c. For phase 2 of the project, any combination of outage and contingency that result in losing two out of the three 230 kV circuits connecting Richview TS to Manby West TS will cause post-contingency flow on the third circuit to exceed the LTE ratings, but remain within the STE ratings.

In each of the aforementioned cases, the connection applicant has committed to reducing the post-contingency loading on the overloaded circuits below their LTE ratings in the time afforded by the short-time ratings as required in section 7.1 of the ORTAC with control actions that may include manually transferring or shedding load in the Metro Toronto and the stations west of Cooksville. In the above 4.a and 4.b, load interruptions for three transmission elements on outage are acceptable under the ORTAC. In 4.c, the amount of load that would need to be interrupted is below 150 MW, which is acceptable under the ORTAC.

The transmitter has advised that the event, of having one circuit out of service during the system peak followed by the loss of an additional two circuits, is a very low probability event. The transmitter also confirmed that if such a situation were to occur, it will take control actions to reduce the remaining circuits flow to within LTE ratings in the time afforded by the short-time ratings as required in section 7.1 of the ORTAC.

IESO Requirements for Connection

Connection Applicant Requirements

General Requirements: The connection applicant shall satisfy all applicable requirements specified in the Market Rules, the TSC and reliability standards. Some of the general requirements that are applicable to this project are presented in detail in Appendix A of this report.

Appendix A: General Requirements

The connection applicant shall satisfy all applicable requirements specified in the Market Rules, the Transmission System Code (TSC) and reliability standards. This Section highlights some of the general requirements that are applicable to the project.

1. The connection applicant must notify the IESO at connection.assessments@ieso.ca as soon as they become aware of any changes to the project scope or data used in this assessment. The IESO will determine whether these changes require a re-assessment.
2. The connection applicant shall ensure that the BPS elements are in compliance with the applicable NPCC criteria and the BES elements in compliance with the applicable NERC reliability standards. To determine the standard requirements that are applicable, the IESO provides mapping tools titled "NPCC Criteria Mapping Spreadsheet" for BPS elements and "NERC Reliability Standard Mapping Tool/Spreadsheet" for BES elements at the IESO's website of [Applicability Criteria for Compliance with Reliability Requirements](#).

Note, the connection applicant may request an exception to the application of the BES definition. The procedure for submitting an application for exemption can be found in Market Manual 11.4: "[Ontario Bulk Electric System \(BES\) Exception](#)" at the IESO's website.

The IESO's criteria for determining applicability of NERC reliability standards and NPCC Criteria can be found in the Market Manual 11.1: "[Applicability Criteria for Compliance with NERC Reliability Standards and NPCC Criteria](#)" at the IESO's website.

Compliance with these reliability standards will be monitored and assessed as part of the IESO's Ontario Reliability Compliance Program. For more details about compliance with applicable reliability standards, the connection applicant is encouraged to contact orcp@ieso.ca and also visit the [Ontario Reliability Compliance Program webpage](#).

However, like any other system element in Ontario, the BPS and BES classifications of the project will be periodically re-evaluated as the electrical system evolves.

3. The connection applicant shall ensure that the project's equipment meet the voltage requirements specified in section 4.2 and section 4.3 of the Ontario Resource and Transmission Assessment Criteria (ORTAC).
4. According to Section 6.1.2 of the TSC, the connection applicant must ensure the project's transmission connection equipment is designed to withstand the fault levels in the area. According to Section 6.4.4 of the TSC, if any future system changes result in an increased fault level higher than the project's equipment capability, the connection applicant is required to replace that equipment with higher rated equipment capable of withstanding the increased fault level, up to the maximum fault level specified in Appendix 2 of the TSC.

It is the connection applicant's responsibility to verify that all equipment and circuit breakers within the project are appropriately sized for the local fault levels.

The connection applicant shall ensure that the circuit breakers installed at the project have rated interrupting time that satisfies Appendix 2 of the TSC. Fault interrupting devices installed at the

project must be able to interrupt fault currents at the applicable maximum continuous voltage as specified in Section 4.2 and Section 4.3 of ORTAC.

5. The connection applicant shall ensure that the protection systems are designed to satisfy all the requirements of the TSC. New protection systems must be coordinated with existing protection systems. Protection systems within the project shall only trip the appropriate equipment isolating the fault.

Associated overvoltage protective relaying must be set to ensure that the project's equipment does not automatically trip for voltages up to 5% above the equipment's corresponding maximum continuous voltage as specified in section 4.2 of the ORTAC.

BPS elements are deemed by the IESO to be essential to system reliability and security and must be protected by redundant protection systems in accordance with Section 8.2 of the TSC. These redundant protection systems must satisfy all requirements of the TSC, and in particular, they must be physically separated and not use common components, common battery banks, or common instrument transformer secondary windings.

The protection systems for transmission voltage BES elements (whose rated voltage is higher than 100 kV) must be redundant. Redundancy must be present in protective relaying for normal fault clearing and control circuitry associated with protective functions including trip coils of the circuit breakers or other interrupting devices. These redundant protection systems must not use common instrument transformer secondary windings. A single communication system, if used, must be monitored and reported and a single DC supply, if used, must be monitored and reported for both low voltage and open circuit.

As the electrical system evolves, transmission voltage non-BPS or non-BES elements (whose rated voltage is higher than 100 kV) within the project, may be re-classified as BPS elements or BES elements. The connection applicant is recommended to design the protection systems for these elements according to the protection requirements for BPS elements or have adequate provisions for future upgrade to meet those requirements.

As currently assessed, the project is not required to participate in a Special Protection System (SPS)/Remedial Action Scheme (RAS). However, the connection applicant is required to have adequate provision in the design of the project's protections and controls to allow for future installation of SPS/RAS equipment in case needed to improve transfer capability in the vicinity of the project or to accommodate transmission reinforcement projects. If the project is required to participate in an SPS/RAS, its SPS/RAS facilities must comply with the NPCC Reliability Reference Directory #7 for Type 1 SPS. In particular, if the SPS/RAS is designed to have redundant 'A' and 'B' protection systems at a single location, they must be on different non-adjacent vertical mounting assemblies or enclosures. Two independent trip coils are required on any breakers to be selected for L/R as part of an SPS/RAS design.

6. The connection applicant shall ensure that the connection equipment is designed to be fully operational in all reasonably foreseeable ambient conditions. Failures of the connection equipment must be contained within the project and have no adverse impact on the IESO-controlled grid.

7. In accordance with Section 7.4 of Chapter 4 of the Market Rules, the connection applicant shall provide to the IESO the applicable telemetry data listed in Appendix 4.16 of the Market Rules on a continual basis. The data shall be provided in accordance with the performance standards set forth in Appendix 4.20 and Appendix 4.21, subject to Section 7.6A of Chapter 4 of the Market Rules. The whole telemetry list will be finalized during the IESO's Market Registration process.

The connection applicant must install monitoring equipment that meets the requirements set forth in Appendix 2.2 of Chapter 2 of the Market rules. As part of the IESO's Market Registration process, the connection applicant must also complete end to end testing of all necessary telemetry points with the IESO to ensure that standards are met and that sign conventions are understood. All found anomalies must be corrected before IESO's final approval to connect any phase of the project is granted.

8. The connection applicant must initiate the IESO's Market Registration process at least eight months prior to the commencement of any project related outages.

The connection applicant is required to provide "as-built" equipment data for the project during the IESO Market Registration process. If the submitted equipment data differ materially from the ones used in this assessment, then further analysis of the project may need to be done by the IESO before final approval to connect is granted.

At the sole discretion of the IESO, performance tests may be required at generation and transmission facilities. The objectives of these tests are to demonstrate that equipment performance meets the IESO requirements, and to confirm models and data are suitable for IESO purposes. The transmitter may also have its own testing requirements. The IESO and the transmitter will coordinate their tests, share measurements and cooperate on analysis to the extent possible.

Once the IESO's Market Registration process has been successfully completed, the IESO will provide the connection applicant with a Registration Approval Notification (RAN) document, confirming that the project is fully authorized to connect to the IESO-controlled grid. For more details about this process, the connection applicant is encouraged to contact IESO's Market Registration at market.registration@ieso.ca

9. The connection applicant is currently a participant in the Ontario Power System Restoration Plan. The connection applicant is required to update its restoration participant attachment to include details regarding its proposed project. For more details, please refer to the Market Manual 7.8. Details regarding restoration participant requirements will be finalized during the IESO Market Registration process.

As currently assessed by the IESO, the project is classified as a Key Facility that is required to establish a Basic Minimum Power System following a system blackout. Testing requirements of Critical Components belonging to Key Facilities are provided in Market Manual 7.8. Key Facility, Basic Minimum Power System and Critical Component terms are defined in the NPCC Glossary of Terms.

10. The Ontario Resource and Transmission Assessment (ORTAC) states that the transmission system must be planned such that, following design criteria contingencies on the transmission system, affected loads can be restored with the restoration times listed below:

- a. All load must be restored within approximately a target of 8 hours;
 - b. When the amount of load interrupted is greater than 150MW, the amount of load in excess of 150MW must be restored within approximately a target of 4 hours;
 - c. When the amount of load interrupted is greater than 250MW, the amount of load in excess of 250MW must be restored within a target of 30 minutes.
11. As per Market Manual 2.10, the connection application will be required to provide a status report of its proposed project with respect to its progress upon request of the IESO using the [project status report form](#) on the IESO website. Failure to comply with project status requirements listed in Market Manual 2.10 will result in the project being withdrawn.

The connection applicant will be required to also provide updates and notifications in order for the IESO to determine if the project is “committed” as per Section 3.3 of Market Manual 2.10.

**Independent Electricity
System Operator**

1600-120 Adelaide Street West
Toronto, Ontario M5H 1T1

Phone: 905.403.6900

Toll-free: 1.888.448.7777

E-mail: customer.relations@ieso.ca

ieso.ca

 [@IESO_Tweets](https://twitter.com/IESO_Tweets)

 facebook.com/OntarioIESO

 linkedin.com/company/IESO

CUSTOMER IMPACT ASSESSMENT

1

2

3 Please refer to **Attachment 1** for the Final CIA prepared by Hydro One.

This page has been left blank intentionally.



Hydro One Networks Inc.
483 Bay Street
Toronto, Ontario
M5G 2P5

CUSTOMER IMPACT ASSESSMENT
HORNER TS: ADD SECOND 75/125 MVA, 230/27.6kV DESN
AND
RICHVIEW TS X MANBY TS: REINFORCE TRANSMISSION

CIA ID: 2019-04
Revision: Final
Date: April 23, 2021

Issued by:
System Planning Division
Hydro One Networks Inc.

Prepared by:

Approved by:

Saleem Shaikh
Network Management Engineer
System Planning Division
Hydro One Networks Inc.

Farooq Qureshy P.Eng
Manager, Transmission Planning (C& E)
System Planning Division
Hydro One Networks Inc.

Disclaimer

This Customer Impact Assessment was prepared based on preliminary information available about the Horner TS – new additional 2nd DESN project and the Richview TS to Manby TS – Reinforce Transmission project. It is intended to highlight significant impacts, if any, to affected transmission customers early in the project development process and thus allow an opportunity for these parties to bring forward any concerns that they may have, including those needed for the review of the connection and for any possible application for Leave to Construct. Subsequent changes to the required modifications or the implementation plan may affect the impacts of the proposed connection identified in this Customer Impact Assessment. The results of this Customer Impact Assessment and the estimate of the outage requirements are subject to change to accommodate the requirements of the IESO and other regulatory or municipal authority requirements. The fault levels computed as part of this Customer Impact Assessment are meant to assess current conditions in the study horizon and are not intended to be for the purposes of sizing equipment or making other project design decisions.

Hydro One Networks shall not be liable to any third party which uses the results of the Customer Impact Assessment under any circumstances whatsoever, for any indirect or consequential damages, loss of profit or revenues, business interruption losses, loss of contract or loss of goodwill, special damages, punitive or exemplary damages, whether any of the said liability, loss or damages, arises in contract, tort or otherwise.

Table of Contents

1.0	Introduction	4
1.1	<i>Purpose</i>	4
1.2	<i>Background</i>	4
1.3	<i>Connected Customers</i>	5
2.0	Study Results.....	5
2.1	<i>Load Flow Analysis.....</i>	6
2.2	<i>Short- Circuit Study</i>	6
2.3	<i>Reliability</i>	6
2.4	<i>Preliminary Outage Impact Assessment.....</i>	7
3.0	Conclusions	7
	<i>Appendix A1: Horner TS - Existing and Proposed Configuration</i>	8
	<i>Appendix A2: Richview TS and Manby TS - Existing and Proposed System Configuration</i>	9
	<i>Appendix B: Short Circuit Levels.....</i>	11

Customer Impact Assessment
Horner TS- Add Second DESN and
Reinforce Richview TS to Manby TS Transmission

1.0 **INTRODUCTION**

1.1 **Purpose**

This Customer Impact Assessment (CIA) study assesses the potential impact of the addition of a second 230/27.6 kV 75/125 MVA DESN unit at Horner TS and the proposed reinforcement of the Richview TS to Manby TS transmission system on the transmission customers in the South West GTA area.

This study is intended to supplement the IESO System Impact Assessment (SIA) reports CAA ID 2016-574, dated December 5th, 2016 for the proposed new Horner DESN and CAA ID 2018-637, dated February 26th, 2021 for the proposed Richview TS to Manby TS Transmission Reinforcement Project.

In accordance with Section 6 of the Ontario Energy Board’s Transmission System Code (TSC), Hydro One Networks Inc. (Hydro One) is to carry out a Customer Impact Assessment study to assess the impact of the proposed project on existing customers in the affected area.

This is the final Customer Impact Assessment for the addition of the second DESN at Horner TS and the reinforcement of the Richview to Manby transmission system. A draft CIA was issued for area customers comments on February 21, 2020. All customer comments have been incorporated.

1.2 **Background**

Manby TS and Horner TS are two 230/27.6 kV transformer stations supplying the load demand in the southwest end of Toronto. Based on the current forecasts, the combined station capacity of the two stations is forecast to be exceeded by summer 2021. Additional step down transformation is required to provide relief.

To address the need for additional step down transformation capacity in the South West Toronto area, the 2016 Metro Toronto Regional Infrastructure Plan report¹ had recommended building a second 230/27.6kV DESN at the existing Horner TS site. Toronto Hydro has asked Hydro One to proceed with building the new facilities. Two 75/125MVA transformers will be installed at the

¹Metro Toronto Regional Infrastructure Plan Report dated January 16, 2016
<https://www.hydroone.com/abouthydroone/CorporateInformation/regionalplans/metrotoronto/Documents/RIP%20Report%20Metro%20Toronto.pdf>

CIA – Horner TS: Add 2nd DESN and Reinforce Richview to Manby Transmission

station along with a new 27.6kV MVGIS with twelve 27.6kV feeders. The existing and proposed facilities at Horner TS are given in Appendix A1 - Figure 1 and 2. The currently planned in-service date for this project is Q1 2022.

The 2016 Metro Toronto Regional Infrastructure Plan report had also identified the need to reinforce the Richview TS to Manby TS transmission system by adding a third double circuit line between Richview TS. This work will be done in two stages as follows:

1. Stage 1 - Operate R2K and R15K circuits as super circuits using the new line.
2. Stage 2 - Unbundle the super circuits and reconfigure with three 230kV circuits connecting Richview TS to Manby East 230kV bus and three 230kV circuits connecting Richview TS to the Manby West 230kV bus. This configuration allows Richview TS to be bypassed and permits continued supply to Manby TS should there be an emergency at Richview TS

The existing and proposed transmission facilities for Stage 1 and Stage 2 work are given in Appendix A2 – Figures 1 to 3.

The Metro Toronto Working Group is currently reviewing the need date for Stage 1 of the project with a decision expected by Q2 2021. The earliest feasible date is for completion of Stage 1 facilities is Q2 2025. The in-service date of Stage 2 facilities has also been revised to coordinate with station sustainment work at Manby TS and it is now planned to be completed by Q4 2030.

1.3 Connected Customers

The focus of this study is on transmission-connected customers supplied by 230kV R1K/R2K, R13K/R15K and the R24C circuits. The customers are listed in Table 1 below.

Table 1. Transmission Connected Customers

Station	Customer
Horner TS	Toronto Hydro
Manby TS	Toronto Hydro
Manby TS	Kinectrics*
Cooksville TS	Alectra
Richview TS	Alectra, Toronto Hydro
Lorne Park TS	Alectra
Ford CTS	Ford Motor Company
Oakville TS	Alectra

*Connected to tertiary winding of the Manby E autotransformers

2.0 STUDY RESULTS

Load flows and short circuit analysis were conducted to assess the impact of the proposed Horner TS second DESN and the Richview TS x Manby TS transmission reinforcement. The voltages were assessed as per IESO's Market Rules for buses 50 kV and above and CSA 235 for buses

CIA – Horner TS: Add 2nd DESN and Reinforce Richview to Manby Transmission

below 50 kV as recommended in the Appendix 2 of Ontario Energy Board’s Transmission System Code (TSC).

2.1 Load Flow Analysis

The forecast loading on the new station will result in an increase in flow on the 230kV double circuit lines R2K/R13K. As part of the proposed transmission reinforcement Horner TS will be tapped off circuits R2K and R15K. The expected in-service date for Stage 1 is Q2 2025.

With the completion of the Stage 2 transmission reinforcement work supply to Horner TS will be moved back to 230kV circuits R2K and R13K.

All line flows are within limit for forecast loading over the next 10 years for all normal single contingencies.

This CIA also assessed the area voltage after the incorporation of second DESN at Horner TS for the base case (with all facilities in service) and for either of the two supply circuits out of service. All bus voltages are within criteria and no voltage violations were found for these conditions.

2.2 Short-Circuit Study

The addition of the second Horner DESN does not result in a significant change in fault level at most buses. However, there is an increase in the fault level primarily at the Manby TS 230kV buses and Cooksville TS 230kV bus as a result of the transmission reinforcement. The short circuit levels at all area HV and LV buses are given in Appendix B (Tables B1 and B2) for four system conditions:

- Case 0 – Existing system
- Case 1 – Existing system with Horner 2nd DESN
- Case 2 – Connection of DESN with Stage 1 of transmission reinforcement
- Case 3 – Connection of DESN with Stage 2 of transmission reinforcement

All area customers are advised to review the short circuit results to ensure that their equipment ratings are adequate to for the increased fault current level.

2.3 Reliability

The proposed transmission reinforcement work will increase supply reliability and adequacy for customers connected in the Southwest Toronto and the Manby East/Manby West 115kV systems.

THESL have advised us of their concern about two 230kV circuits supplying Horner TS and that supply to the station can be affected under N-1-1 events. One way to remedy this deficiency is to consider a third supply to Horner TS. While the current arrangement is in accordance with the

CIA – Horner TS: Add 2nd DESN and
Reinforce Richview to Manby Transmission

ORTAC criteria, it is recommended that supply to Horner TS be reviewed in the next round of Regional Planning Studies.

2.4 Preliminary Outage Impact Assessment

Exact outage schedule will be made available during the execution phase of the project and will be established in consultation with load customers in the area. The outage duration, if any, will be minimized and risk managed with proper outage planning and co-ordination.

3.0 CONCLUSIONS

This report concludes that the incorporation of second DESN at Horner TS and the proposed transmission reinforcement will not have any adverse effect on the voltage in the area and the project will improve the supply reliability to the South West Toronto area.

The fault levels at all stations in the area experience a minor increase except for Manby TS and Cooksville TS, which see an increase as a result of the transmission reinforcement. Customers are requested to review the fault levels provided in Appendix B to ensure to ensure that the capability of their equipment is not exceeded.

Appendix A1: Horner TS - Existing and Proposed Configuration

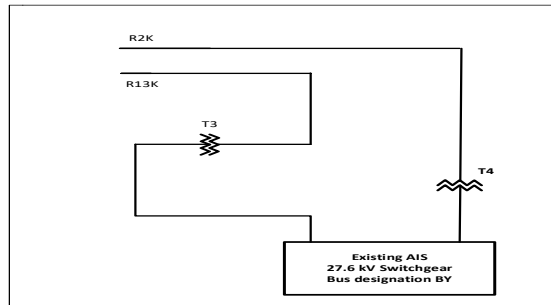

Figure 1- Horner TS: Existing Facilities

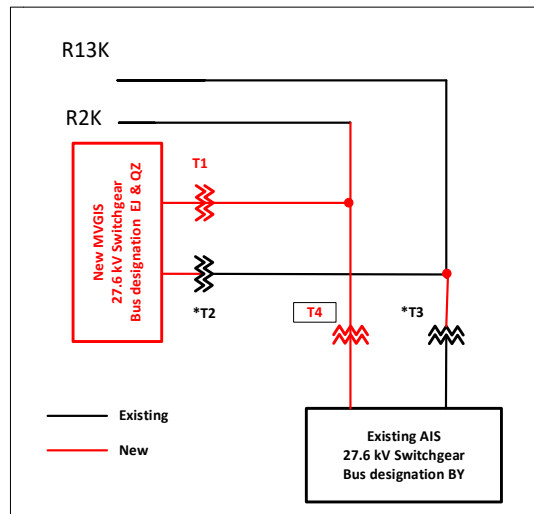

Figure 2- Horner TS: Proposed Facilities

Notes.

*The existing T3 transformer is designated as T2. Existing transformer T4 will be renamed T3

Appendix A2: Richview TS and Manby TS - Existing and Proposed System Configuration

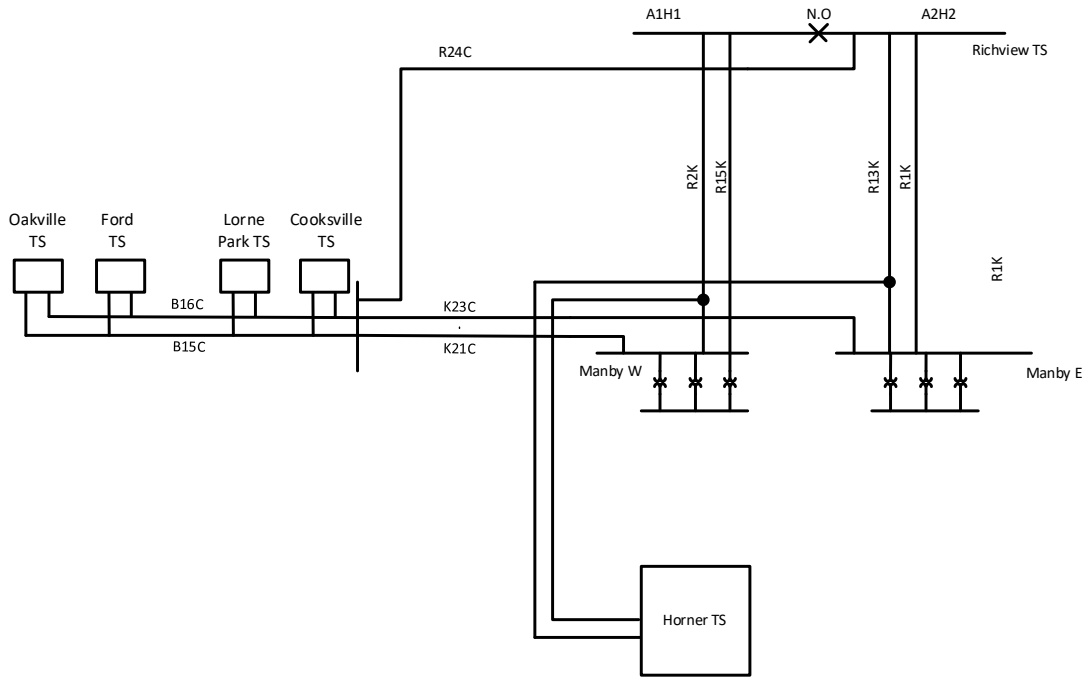
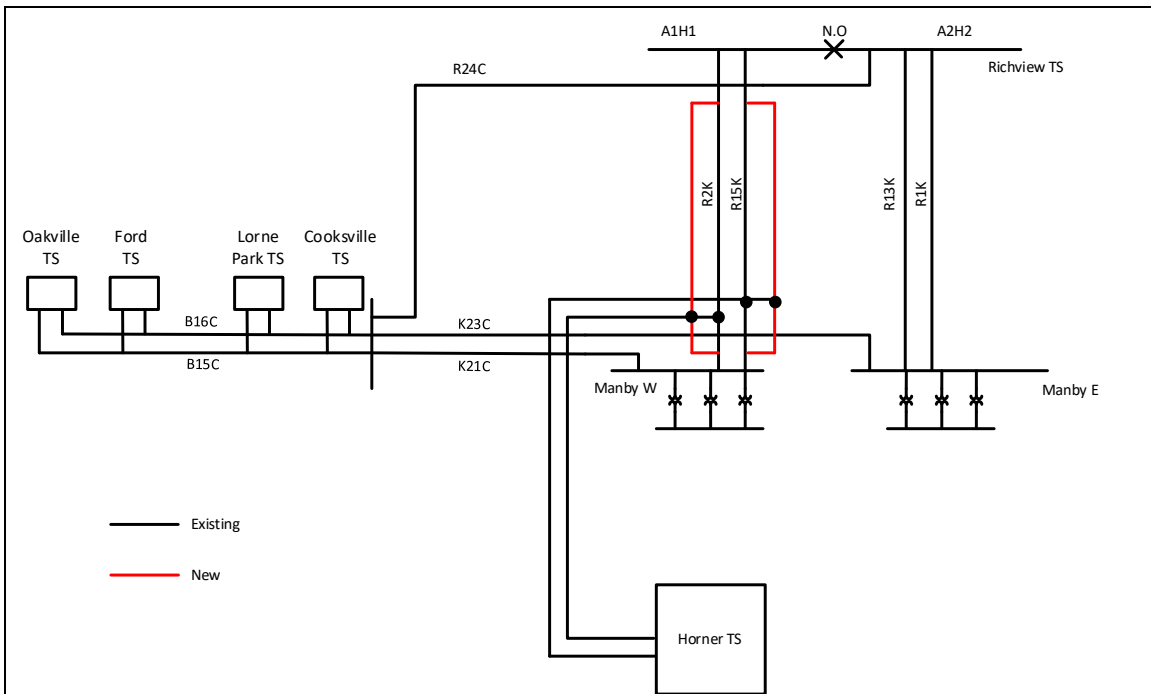

Figure 1- Richview TS x Manby TS Transmission – Existing facilities



L21C

Figure 2- Richview TS x Manby TS Transmission – Stage 1 facilities

CIA – Horner TS: Add 2nd DESN and Reinforce Richview to Manby Transmission

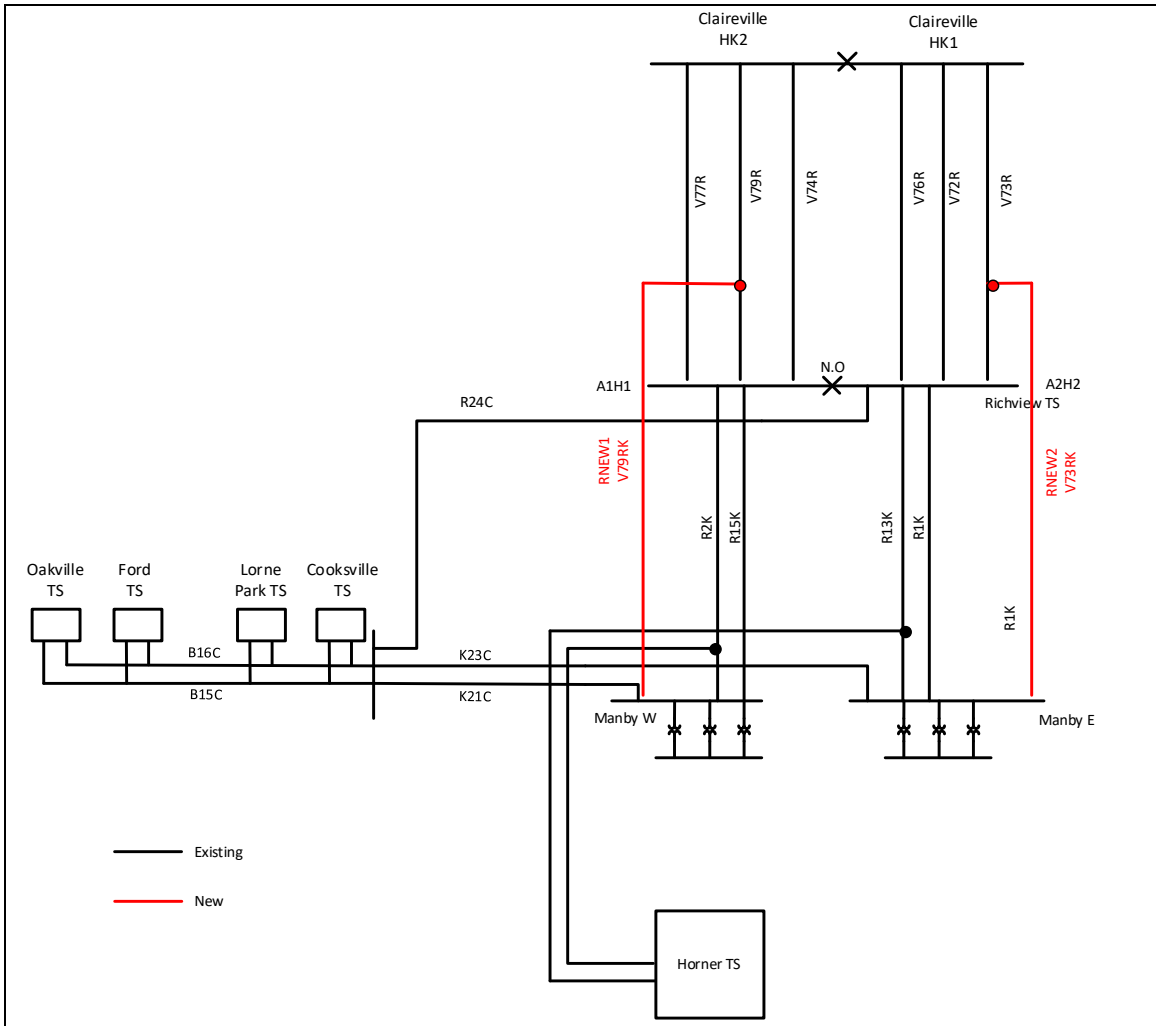

Figure 3- Richview TS x Manby TS Transmission – Stage 2 facilities

CIA – Horner TS: Add 2nd DESN and
Reinforce Richview to Manby Transmission

Appendix B: Short Circuit Levels

Table B1 and B2 show the short circuit levels for the areas HV and LV buses. The fault studies are based on the IESO 2020 System Short Circuit Base case and includes Maximum System Generation with Richview TS and Claireville TS 230kV bus tie breakers operated open. Local Generation at Horner TS includes three generators totaling 12.5MW connected to Bus#3685.

Table B1(a). Short circuit Levels (3-Ph.) for 220kV & 118kV Buses

BASKV	BUS#	Bus Name	3 Ph Sym				3 Ph Asym				Breaker Ratings	
			Case-0	Case-1	Case-2	Case-3	Case-0	Case-1	Case-2	Case-3	Sym (kA)	Asym (kA)
220	3100	HORNER R13K	33.3	33.6		35.9	39.7	40.5		43.3		
	3100	HORNER R15K			38.5				45.6			
	3101	HORNER R2K	35.3	35.6	38.5	37.8	42.1	42.8	45.6	45.5		
	3107	MANBY EAST	44.5	44.6	45.0	49.2	55.3	55.6	55.8	61.6	63.0	78.8
	3108	MANBY WEST	47.1	47.2	53.1	51.3	58.5	58.7	66.5	64.1	63.0	81.9
	4100	CLAIRVIL HK1	62.8	62.8	62.9	63.0	85.9	85.9	86.0	86.1	80.0	96.0
	4103	RICHVIEW AH2	62.6	62.6	63.0	63.2	80.6	80.7	81.1	81.5	80.0	104.0
	4105	RICHVIEW AH1	61.6	61.6	62.3	62.3	78.4	78.5	79.4	79.4	80.0	104.0
	4108	CLAIRVIL HK2	63.6	63.6	63.8	63.8	86.7	86.7	87.0	86.9	80.0	96.0
	4145	COOKSVILLE	44.0	44.0	46.7	46.4	54.8	54.8	58.2	57.8	63.0	81.9
	4146	COOKSVIL B16	44.0	44.0	46.7	46.4	54.8	54.8	58.2	57.8		
	4147	COOKSVIL PHJ	44.0	44.0	46.7	46.4	50.4	50.4	53.5	53.1		
	4159	FINCH J C4R	27.0	27.0	27.1	27.1	28.9	28.9	29.0	29.0		
	4160	FINCH J P21R	29.7	29.7	29.8	29.8	32.3	32.3	32.4	32.4		
	4161	FINCH J P22R	30.5	30.5	30.5	30.5	33.5	33.5	33.6	33.6		
	4165	FINCH TS C4R	26.3	26.3	26.4	26.4	28.1	28.1	28.2	28.2		
	4192	LORNE PK B15	26.9	26.9	27.9	27.8	30.4	30.4	31.5	31.4		
	4193	LORNE PK B16	26.8	26.8	27.7	27.6	30.2	30.2	31.3	31.2		
	4200	REXDALE V74R	47.0	47.1	47.2	47.2	54.4	54.4	54.6	54.6		
	4201	REXDALE V76R	46.9	46.9	47.0	47.0	54.5	54.5	54.6	54.7		
4202	TOMKEN R14T	33.7	33.7	33.7	33.7	36.3	36.3	36.4	36.4			
4203	TOMKEN R17T	33.9	33.9	34.0	34.0	36.6	36.6	36.7	36.7			
4204	TOMKEN R19T	39.4	39.4	39.4	39.4	42.8	42.8	42.8	42.9			
5187	FORD OAKVL15	16.5	16.5	16.8	16.8	18.5	18.5	18.9	18.9			
5188	FORD OAKVL16	16.4	16.4	16.7	16.7	18.4	18.4	18.8	18.8			
5240	OAKVIL #2B15	16.3	16.3	16.7	16.6	20.0	20.0	20.4	20.4			
5241	OAKVIL #2B16	16.3	16.3	16.6	16.6	19.9	19.9	20.3	20.3			
118.05	3302	MANBY EAST	27.7	27.7	27.8	28.6	35.8	35.9	35.9	37.2	50.0	75.0
	3303	MANBY WEST	28.6	28.7	29.6	29.3	37.0	37.1	38.6	38.2	63.0	75.6
	3367	FAIRBANK K1W	13.3	13.3	13.3	13.5	14.4	14.4	14.4	14.6		
	3368	FAIRBANK K3W	13.3	13.3	13.3	13.5	14.4	14.4	14.4	14.6		
	3377	JOHN TS	20.5	20.5	21.0	20.9	22.9	22.9	23.4	23.3	34.7	41.6
	3391	RUNNYMED K11	19.7	19.7	19.7	20.1	23.8	23.8	23.8	24.4		
	3392	RUNNYMED K12	19.7	19.7	19.7	20.1	23.8	23.8	23.8	24.4		
	3395	STRACHAN H2J	19.7	19.7	20.1	20.0	21.8	21.8	22.3	22.1		
	3396	STRACHAN K6J	19.7	19.7	20.1	20.0	21.8	21.8	22.3	22.2		
	3409	WILTSHIRE H2	21.1	21.1	21.2	21.6	25.6	25.7	25.7	26.3	31.0	34.1
3410	WILTSHIR H13	21.1	21.1	21.2	21.6	25.6	25.7	25.7	26.3	31.0	34.1	
3439	STRACH PHE13	19.7	19.7	20.2	20.0	21.7	21.7	22.2	22.0			
3440	STRACH PHE14	19.7	19.7	20.2	20.0	21.7	21.7	22.2	22.0			

Table B1(b). Short circuit Levels (L-G) for 220kV & 118kV Buses

BASKV	BUS#	Bus Name	SLG-Sym				SLG-Asym				Breaker Ratings	
			Case-0	Case-1	Case-2	Case-3	Case-0	Case-1	Case-2	Case-3	Sym (kA)	Asym (kA)
220	3100	HORNER R13K	27.8	28.2		30.1	31.5	32.0		34.0		
	3100	HORNER R15K			32.7				36.8			
	3101	HORNER R2K	29.7	30.0	32.7	32.0	33.7	34.2	36.9	36.2		
	3107	MANBY EAST	40.2	40.5	41.3	45.0	51.1	51.5	52.1	57.3	63.0	78.8
	3108	MANBY WEST	42.6	42.9	49.0	47.1	55.1	55.5	63.2	60.8	63.0	81.9
	4100	CLAIRVIL HK1	63.6	63.7	63.7	63.8	87.6	87.6	87.6	87.8	80.0	96.0
	4103	RICHVIEW AH2	56.6	56.7	57.0	57.6	72.1	72.3	72.5	73.7	80.0	104.0
	4105	RICHVIEW AH1	54.2	54.3	56.3	55.7	68.1	68.3	71.7	70.6	80.0	104.0
	4108	CLAIRVIL HK2	64.1	64.1	64.6	64.5	87.1	87.1	87.8	87.6	80.0	96.0
	4145	COOKSVILLE	36.1	36.2	38.2	37.9	44.4	44.6	46.8	46.5	63.0	81.9
	4146	COOKSVIL B16	36.1	36.2	38.2	37.9	44.4	44.6	46.8	46.5		
	4147	COOKSVIL PHJ	36.1	36.2	38.2	37.9	40.9	41.0	43.1	42.8		
	4159	FINCH J C4R	20.9	20.9	21.1	21.0	22.1	22.1	22.3	22.3		
	4160	FINCH J P21R	23.7	23.7	23.9	23.9	25.1	25.1	25.4	25.3		
	4161	FINCH J P22R	24.5	24.5	24.5	24.6	26.0	26.0	26.0	26.1		
	4165	FINCH TS C4R	20.4	20.4	20.6	20.5	21.6	21.6	21.8	21.7		
	4192	LORNE PK B15	20.3	20.4	21.0	20.9	21.7	21.7	22.4	22.3		
	4193	LORNE PK B16	20.2	20.3	20.9	20.8	21.6	21.6	22.2	22.2		
	4200	REXDALE V74R	43.1	43.1	43.6	43.4	47.4	47.4	47.9	47.8		
	4201	REXDALE V76R	43.2	43.2	43.2	43.4	47.7	47.7	47.7	47.9		
	4202	TOMKEN R14T	26.0	26.0	26.2	26.1	27.5	27.5	27.7	27.6		
	4203	TOMKEN R17T	26.5	26.5	26.7	26.7	28.0	28.0	28.2	28.1		
	4204	TOMKEN R19T	33.6	33.7	33.7	33.7	36.1	36.1	36.1	36.2		
	5187	FORD OAKVL15	12.0	12.0	12.2	12.2	12.7	12.7	12.9	12.9		
	5188	FORD OAKVL16	11.9	11.9	12.1	12.1	12.6	12.6	12.8	12.8		
5240	OAKVIL #2B15	11.9	11.9	12.1	12.1	13.3	13.3	13.5	13.5			
5241	OAKVIL #2B16	11.9	11.9	12.1	12.0	13.2	13.3	13.5	13.4			
118.05	3302	MANBY EAST	32.6	32.7	32.8	33.7	42.9	43.0	43.1	44.7	50.0	75.0
	3303	MANBY WEST	33.5	33.6	34.9	34.5	44.4	44.5	46.5	46.0	63.0	75.6
	3367	FAIRBANK K1W	8.7	8.7	8.7	8.8	9.2	9.2	9.2	9.2		
	3368	FAIRBANK K3W	8.7	8.7	8.7	8.8	9.2	9.2	9.2	9.2		
	3377	JOHN TS	16.0	16.1	16.3	16.3	17.3	17.3	17.6	17.5	34.7	41.6
	3391	RUNNYMED K11	16.2	16.3	16.3	16.5	17.9	17.9	18.0	18.2		
	3392	RUNNYMED K12	16.2	16.2	16.3	16.5	17.9	17.9	18.0	18.2		
	3395	STRACHAN H2J	15.3	15.3	15.6	15.5	16.3	16.3	16.6	16.5		
	3396	STRACHAN K6J	15.4	15.4	15.6	15.6	16.4	16.4	16.6	16.6		
	3409	WILTSHIRE H2	15.1	15.1	15.1	15.3	17.4	17.4	17.4	17.6	31.0	34.1
	3410	WILTSHIR H13	15.0	15.0	15.0	15.2	17.3	17.3	17.3	17.5	31.0	34.1
	3439	STRACH PHE13	15.2	15.2	15.5	15.4	16.1	16.1	16.3	16.3		
	3440	STRACH PHE14	15.2	15.2	15.5	15.4	16.1	16.1	16.4	16.3		

CIA – Horner TS: Add 2nd DESN and
Reinforce Richview to Manby Transmission

Table B2(a). Short circuit Levels (3-Ph.) for 44kV, 27.6kV and 13.8kV Buses

BASKV	BUS#	Bus Name	3 Ph Sym				3 Ph Asym				Ratings		
			Case-0	Case-1	Case-2	Case-3	Case-0	Case-1	Case-2	Case-3	Sym (kA)	Asym (kA)	
44	4736	TOMKEN TS BY	15.3	15.3	15.3	15.3	16.5	16.5	16.5	16.5	17.0	18.7	
	4737	TOMKEN TS EZ	14.9	14.9	14.9	14.9	16.5	16.5	16.5	16.5	23.0	27.6	
27.6	3678	FAIRBANK BQ	14.5	14.5	14.5	14.5	14.9	14.9	14.9	14.9	15.0	18.1	19.9
	3679	FAIRBANK YZ	14.2	14.2	14.2	14.3	14.7	14.7	14.7	14.7	18.1	19.9	
	3684	HORNER TS B	14.0	14.0	13.9	14.0	16.0	16.0	15.8	16.0	18.1	19.9	
	3685	HORNER TS Y	14.7	14.7	14.6	14.8	16.8	16.8	16.6	16.8	18.1	19.9	
	3734	MANBY E QZ	11.8	11.9	11.9	11.9	12.4	12.4	12.4	12.4	18.1	19.9	
	3740	MANBY W FV	14.7	14.7	14.8	14.8	17.1	17.1	17.2	17.2	18.1	19.9	
	3742	MANBY W BY	12.6	12.6	12.7	12.7	13.2	13.2	13.2	13.2	18.1	19.9	
	3757	RUNNYMED JQ	13.9	13.9	13.9	14.0	15.2	15.2	15.2	15.3	31.5	37.8	
	3758	RUNNYMEDE BY ²	14.6	14.6	14.6	14.7	15.7	15.7	15.7	15.7	18.1	19.9	
	4629	COOKSVIL EZ	19.1	19.1	19.1	19.1	20.8	20.8	20.9	20.9	31.5	37.8	
	4631	COOKSVIL JQ	16.7	16.7	16.8	16.8	18.5	18.5	18.5	18.5	18.1	19.9	
	4658	FINCH TS B	13.6	13.6	13.6	13.6	14.3	14.3	14.3	14.3	29.9	32.8	
	4659	FINCH TS Y	14.1	14.1	14.1	14.1	14.9	14.9	14.9	14.9	29.9	32.8	
	4660	FINCH TS Q	14.6	14.6	14.6	14.6	15.4	15.4	15.4	15.4	29.9	32.8	
	4661	FINCH TS J	14.5	14.5	14.5	14.5	15.3	15.3	15.3	15.3	29.9	32.8	
	4697	LORNE PARK B	13.6	13.6	13.7	13.7	14.7	14.7	14.7	14.7	29.9	32.8	
	4723	REXDALE BY	14.1	14.1	14.1	14.1	16.2	16.2	16.2	16.2	31.5	34.7	
	4727	RICHVIEW BY	16.5	16.5	16.5	16.5	18.5	18.5	18.5	18.5	18.1	19.9	
	4728	RICHVIEW E	14.8	14.8	14.8	14.8	15.7	15.7	15.7	15.7	29.9	32.8	
	4729	RICHVIEW J	14.9	14.9	14.9	14.9	15.7	15.7	15.7	15.7	29.9	32.8	
6050	FORD OAKVL	12.4	12.4	12.4	12.4	13.3	13.3	13.3	13.3				
6168	OAKVILLE #2E	13.7	13.7	13.8	13.8	14.5	14.5	14.5	14.5	29.9	32.8		
6169	OAKVILLE #2Z	13.9	13.9	13.9	13.9	14.6	14.6	14.6	14.6	29.9	32.8		
36861	HORNER EJ ³		13.3	13.2	13.3		15.3	15.1	15.3	31.5	37.8		
36871	HORNER QZ ³		13.3	13.2	13.3		15.2	15.1	15.3	31.5	37.8		
13.8 ¹	3687	JOHN TS A3A4	16.7	16.7	16.7	16.7	16.7	16.7	16.7	16.7	35.2	38.7	
	3696	JOHN TSA1112	15.6	15.6	15.6	15.6	16.2	16.2	16.3	16.2	24.3	26.7	
	3697	JOHN TS A1314 ⁴	19.7	19.7	19.7	19.7	19.8	19.8	19.8	19.8	17.5	19.2	
	3698	JOHN TSA1516	15.6	15.6	15.6	15.6	16.2	16.2	16.3	16.2	29.6	32.5	
	3701	JOHN TSA1718	16.4	16.4	16.4	16.4	16.7	16.7	16.8	16.7	19.0	20.9	
	3702	JOHN TS A5A6	16.7	16.7	16.7	16.7	16.7	16.7	16.7	16.7	35.2	38.7	
	3735	MANBY E T7 ⁵	49.9	49.9	49.9	50.2	57.2	57.3	57.3	57.7	63.0	75.6	
	3736	MANBY E T8 ⁵	45.5	45.5	45.5	45.7	48.6	48.7	48.7	49.0	63.0	75.6	
	3737	MANBY E T9 ⁵	49.9	49.9	49.9	50.1	57.2	57.3	57.3	57.7	63.0	75.6	
	3759	STRACHAN A12	16.9	16.9	17.0	17.0	17.7	17.7	17.8	17.8	25.0	27.5	
	3762	STRACH A1112	17.2	17.2	17.3	17.3	17.7	17.7	17.7	17.7	31.5	34.7	
	3781	WILTSH A1112	16.0	16.0	16.0	16.0	17.6	17.6	17.6	17.6	25.0	27.5	
	3783	WILTSHIR A56	16.5	16.5	16.5	16.5	17.3	17.3	17.3	17.3	20.4	20.4	
3784	WILTSH A1314	15.9	15.9	15.9	16.0	17.5	17.5	17.5	17.6	25.0	30.0		
3787	STRACH A910	17.6	17.6	17.7	17.6	18.4	18.4	18.5	18.5	40.0	48.0		

For Notes – See next page

Table B2(b). Short circuit Levels (L-G) for 44kV, 27.6kV and 13.8kV Buses

BASKV	BUS#	Bus Name	SLG-Sym				SLG-Asym				Bkr Ratings	
			Case-0	Case-1	Case-2	Case-3	Case-0	Case-1	Case-2	Case-3	Sym (kA)	Asym (kA)
44	4736	TOMKEN TS BY	7.0	7.0	7.0	7.0	8.5	8.5	8.5	8.5	17.0	18.7
	4737	TOMKEN TS EZ	6.9	6.9	6.9	6.9	8.5	8.5	8.5	8.5	23.0	27.6
27.6	3678	FAIRBANK BQ	11.1	11.1	11.1	11.1	12.3	12.3	12.3	12.4	18.1	19.9
	3679	FAIRBANK YZ	10.6	10.6	10.6	10.7	11.8	11.8	11.8	11.8	18.1	19.9
	3684	HORNER TS B	10.5	10.5	10.5	10.6	12.9	12.9	12.9	13.0	18.1	19.9
	3685	HORNER TS Y	12.1	12.1	12.0	12.1	14.7	14.7	14.6	14.7	18.1	19.9
	3734	MANBY E QZ	9.8	9.8	9.8	9.8	11.3	11.3	11.3	11.4	18.1	19.9
	3740	MANBY W FV	11.0	11.0	11.0	11.0	13.0	13.0	13.1	13.1	18.1	19.9
	3742	MANBY W BY	10.1	10.1	10.2	10.1	11.8	11.8	11.8	11.8	18.1	19.9
	3757	RUNNYMED JQ	10.8	10.8	10.8	10.8	12.9	12.9	12.9	13.0	31.5	37.8
	3758	RUNNYMED TS ²	12.5	12.5	12.5	12.5	13.2	13.2	13.2	13.2	18.1	19.9
	4629	COOKSVIL EZ	12.5	12.5	12.6	12.6	15.2	15.2	15.2	15.2	31.5	37.8
	4631	COOKSVIL JQ	11.7	11.7	11.7	11.7	14.3	14.3	14.3	14.3	18.1	19.9
	4658	FINCH TS B	10.5	10.5	10.5	10.5	12.3	12.3	12.3	12.3	29.9	32.8
	4659	FINCH TS Y	10.7	10.7	10.7	10.7	12.6	12.6	12.6	12.6	29.9	32.8
	4660	FINCH TS Q	10.7	10.7	10.7	10.7	12.7	12.7	12.7	12.7	29.9	32.8
	4661	FINCH TS J	10.7	10.7	10.7	10.7	12.6	12.6	12.6	12.6	29.9	32.8
	4697	LORNE PARK B	10.4	10.4	10.4	10.4	12.4	12.4	12.4	12.4	29.9	32.8
	4723	REXDALE BY	10.6	10.6	10.6	10.6	13.0	13.0	13.0	13.0	31.5	34.7
	4727	RICHVIEW BY	11.7	11.7	11.7	11.7	14.3	14.3	14.3	14.3	18.1	19.9
	4728	RICHVIEW E	10.8	10.8	10.8	10.8	12.9	12.9	12.9	12.9	29.9	32.8
	4729	RICHVIEW J	10.9	10.9	10.9	10.9	12.9	12.9	12.9	12.9	29.9	32.8
	6050	FORD OAKVLAB	11.9	11.9	12.0	12.0	14.1	14.1	14.1	14.1		
	6168	OAKVILLE #2E	10.5	10.5	10.5	10.5	12.3	12.3	12.3	12.3	29.9	32.8
	6169	OAKVILLE #2Z	10.5	10.5	10.5	10.5	12.3	12.3	12.3	12.3	29.9	32.8
36861	HORNER EJ ³		10.3	10.2	10.3		12.7	12.6	12.7	31.5	37.8	
36871	HORNER QZ ³		10.3	10.2	10.3		12.8	12.7	12.8	31.5	37.8	
13.8 ¹	3687	JOHN TS A3A4	1.9	1.9	1.9	1.9	2.3	2.3	2.3	2.3	35.2	38.7
	3696	JOHN TSA1112	1.9	1.9	1.9	1.9	2.4	2.4	2.4	2.4	24.3	26.7
	3697	JOHN TS A1314 ⁴	2.3	2.3	2.3	2.3	2.8	2.8	2.8	2.8	17.5	19.2
	3698	JOHN TSA1516	1.9	1.9	1.9	1.9	2.4	2.4	2.4	2.4	29.6	32.5
	3701	JOHN TSA1718	1.9	1.9	1.9	1.9	2.4	2.4	2.4	2.4	19.0	20.9
	3702	JOHN TS A5A6	1.9	1.9	1.9	1.9	2.3	2.3	2.3	2.3	35.2	38.7
	3735	MANBY E T7 ⁵	0.0	0.0	0.0	0.0	0.0	0.0	0.0	0.0	63.0	75.6
	3736	MANBY E T8 ⁵	0.0	0.0	0.0	0.0	0.0	0.0	0.0	0.0	63.0	75.6
	3737	MANBY E T9 ⁵	0.0	0.0	0.0	0.0	0.0	0.0	0.0	0.0	63.0	75.6
	3759	STRACHAN A12	10.0	10.0	10.0	10.0	11.7	11.7	11.7	11.7	25.0	27.5
	3762	STRACH A1112	1.7	1.7	1.7	1.7	2.0	2.0	2.0	2.0	31.5	34.7
	3781	WILTSH A1112	9.7	9.7	9.7	9.7	11.9	11.9	11.9	11.9	25.0	27.5
	3783	WILTSHIR A56	9.8	9.8	9.8	9.8	11.3	11.3	11.3	11.3	20.4	20.4
	3784	WILTSH A1314	9.7	9.7	9.7	9.7	11.9	11.9	11.9	11.9	25.0	30.0
	3787	STRACH A910	10.2	10.2	10.2	10.2	11.9	11.9	11.9	11.9	40.0	48.0

Notes:

1. Ratings shown for Hydro One transformer breakers. THESL owns all 13.8kV feeder breakers at listed stations except for Manby TS.
2. Runnymede TS BY bus (#3758) breakers are rated $I_{sym}=18.1kA$, $I_{asym}=19.9kA$. However, the BY bus is being replaced with new MVGIS equipment and new breakers will be rated $I_{sym}=31.5kA$, $I_{asym}=37.8kA$.
3. Second Horner (Bus# 36861 & 36871) new MVGIS and breakers will be rated $I_{sym}=31.5kA$, $I_{asym}=37.8kA$.
4. Ratings are for transformer breakers. The fault current seen by these breakers is half of the bus fault current.
5. These breakers (Bus#3735 & 3736) are supplied from the Tertiary winding of Manby autotransformer T7, T8 & T9.

This page has been left blank intentionally.



Toronto Integrated Regional Resource Plan Addendum: Richview x Manby 230 kV Circuit Upgrades

November 2021

Table of Contents

Table of Contents	1
1 Executive Summary	2
2 Background	4
3 Updated Assumptions	5
3.1 Updated Demand Forecast	5
3.2 Updated Conservation and Demand Management Assumptions	7
3.3 Dufferin TS Supply	8
3.4 Updated Contingencies Considered	10
4 Updated Richview x Manby Needs Assessment	11
5 Updated Options Analysis	12
5.1 Incremental CDM	12
5.2 Distributed Energy Resources	14
5.3 FACTS Devices	15
5.4 Richview x Manby Transmission Reinforcement	18
6 Revised Planning Outcomes	19
6.1 Preferred Solution	19
6.2 Potential Mitigation Measures Before Implementation of Preferred Solution	20

1 Executive Summary

This Toronto Integrated Regional Resource Plan (IRRP) addendum is recommending that Hydro One proceed with the reinforcement of the Richview TS to Manby TS (Richview x Manby) transmission corridor, targeting an in-service date of 2025, which the working group understands is the earliest possible in-service date given the project lead-time. The reinforcement includes replacing the idle 115 kV double circuit line with a new double circuit 230 kV line and the associated connection work at each end. This reinforcement was found to be the most feasible and cost-effective means of addressing an immediate supply capacity need in the Richview South area, and is consistent with the recommendation made in the 2019 Toronto IRRP.

Since the publication of the 2019 Toronto IRRP, there have been changes in planning assumptions that have necessitated re-studying a key recommendation in the 2019 IRRP to reinforce the Richview x Manby transmission corridor to meet a near-term supply capacity need. These changes include an updated Conservation and Demand Management (CDM) Achievable Potential Study, the launch of the 2021-2024 CDM Framework, and updates to the demand forecast in the area. These changes are relevant as they impact both the characteristics of the supply capacity need and the options available to meet this need.

The Addendum Study was initiated specifically to study the electricity reliability needs in the area served by the Richview x Manby transmission corridor (the "Richview South" area) given the updated demand forecast and other system assumptions, and the options to address this need given the updated information with respect to CDM and other non-wires alternatives as applicable. One such system assumption that has a significant impact on the evaluation of alternatives relates to changes in operating policy which require Dufferin TS to be transferred from Leaside TS supply to Manby TS supply during certain system conditions. This transfer has the effect of increasing the magnitude of the supply capacity need and therefore feasible alternatives should have the capability to supply this additional load when these transfers occur.

The reassessment of the need confirmed that there is a supply capacity need along the Richview x Manby transmission corridor starting in 2021; however, the magnitude of this need has increased compared to that in the 2019 IRRP. This increase is attributable to an increase in the demand forecast for the area, as a result of increased customer connections, and is further increased when considering the operating policy and Dufferin TS transfers to Manby TS. Following a review of options, including consideration of non-wires alternatives such as incremental cost-effective CDM, storage and demand response, as well as flexible AC transmission system (FACTS) devices, the recommendation for a transmission upgrade to address the Richview x Manby need has been reaffirmed. The transmission upgrade remains the most cost-effective option that alleviates the supply capacity need and maintains system reliability.

Given that the need is present day, and the transmission upgrade is not expected to come into service until 2025 given its lead-time, it is recommended that short-term measures, such as incremental cost-effective CDM and demand response (such as THESL's Local Demand Response program), be pursued where feasible and cost-effective to assist in reducing customer reliability risk until the transmission upgrade can come into service. While the Local Initiatives Program as part of the 2021-2024 CDM Framework will acquire a portion of the incremental cost-effective CDM, a new implementation mechanism would need to be developed to acquire the remaining portion.

2 Background

The Toronto IRRP, published August 9, 2019, identified a key near-term need associated with electricity supply capacity to the Richview South area. This area is defined electrically as being served by the Richview x Manby transmission corridor, and roughly comprises the western half of central and downtown Toronto, from the financial district in the east, Lawrence avenue to the north, and Etobicoke to the west, and portions of southern Mississauga and Oakville.

To address this need, the IRRP recommended that Hydro One reinforce the Richview TS to Manby TS transmission corridor. This corridor currently consists of two active 230 kV double circuit lines, and an idle 115kV double circuit line. The reinforcement would replace the idle 115 kV double circuit line with a new double circuit 230 kV line, in addition to associated connection work at each end. Following the 2019 IRRP, the regional planning Technical Working Group (consisting of IESO, Hydro One and Toronto Hydro) continued to recommend the Richview TS to Manby TS reinforcement in the Regional Infrastructure Plan published by Hydro One in March 2020.

As part of its ongoing planning efforts, the Technical Working Group continues to monitor developments in the region, even after plan completion, to identify signposts of change that should be considered in terms of their impact on the plan recommendations. In the case of the 2019 Toronto IRRP, there have been a number of changes including: the release of the 2021-2024 Conservation and Demand Management (CDM) Framework, additional information on the cost-effective CDM potential in the region through the Achievable Potential Study, and updates to the demand forecast. These changes should be considered as they impact both the characteristics of the supply capacity need and the options available to address this need.

As a result of these changes, and their potential impact on the Toronto IRRP recommendations, the IESO has undertaken an addendum study focused specifically on the area served by the Richview x Manby transmission corridor (i.e., the Richview South Area) so as to explore these changes and update or confirm the plan recommendations as appropriate.

3 Updated Assumptions

This section summarizes updates to the planning assumptions considered in the revised assessment of needs undertaken as part of this Addendum Study. Study assumptions not described in this Section are consistent with those in the 2019 IRRP.

3.1 Updated Demand Forecast

Toronto Hydro (THESL) provided an updated coincident demand forecast which reflects the most recent information with respect to customer connections. Due to the narrowed area of focus of the Addendum Study, updated forecasts were only provided for stations within the Richview South Area¹. Demand forecasts for the applicable stations in southern Mississauga and Oakville were aligned with those used in the 2021 GTA West IRRP².

The graph below in Figure 1 compares the 2019 IRRP forecast with the updated forecast provided by THESL, for the area covered by this addendum. Note that in both cases, the impact of past conservation programs (i.e., those as part of the Conservation First Framework and Interim Framework) is included. The impact of CDM is described in Section 3.2.

¹ A forecast was also provided for Dufferin TS, which is normally supplied by Leaside TS but transferred to Manby TS under certain system conditions.

² GTA West Regional Planning, <https://www.ieso.ca/en/Get-Involved/Regional-Planning/GTA-and-Central-Ontario/GTA-West>

Figure 1 | Summer Coincident Peak Demand – 2020 THESL update vs 2019 Toronto IRRP³

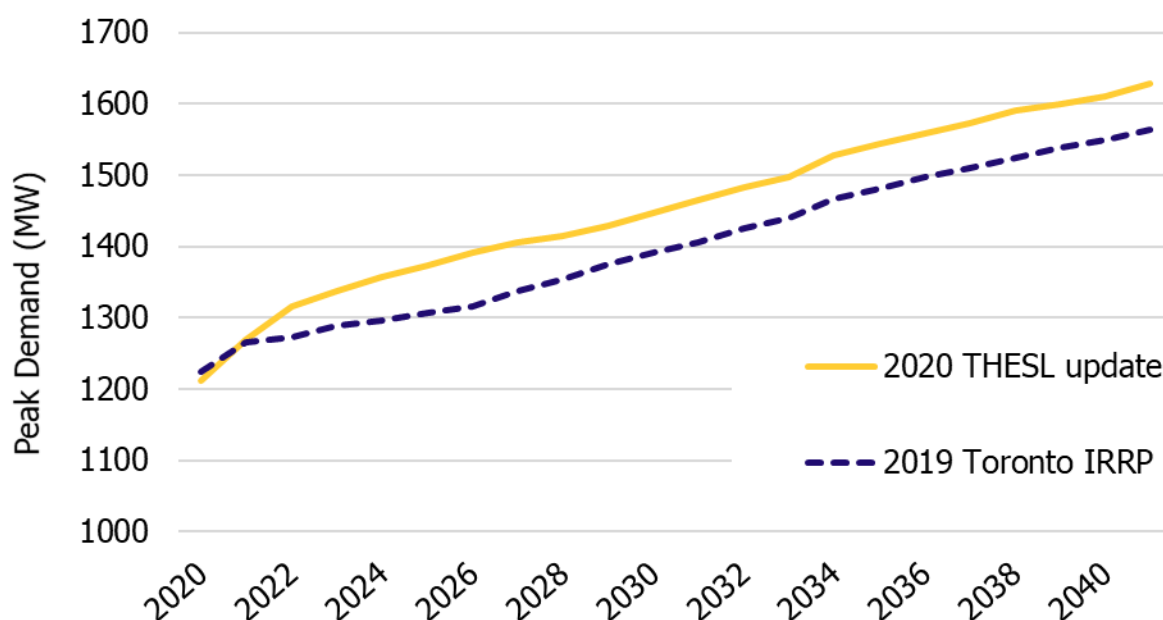

The updated forecast shows higher demand growth rate over the first three to five years of the forecast period compared to the 2019 IRRP forecast, followed by a rate of growth consistent with the 2019 IRRP forecast thereafter. After the first five years of the forecast, the demand from the THESL stations is approximately 60 MW higher (on average, per year) than the 2019 IRRP forecast for the remainder of the forecast period. THESL has indicated that a key driver of the changes in the 2020 demand forecast is new connection requests for primarily residential and commercial development.

Interest in electrification initiatives to reduce reliance on fossil fuels, and thereby greenhouse gas emissions, has been increasing in recent years and is a central theme in the City of Toronto's Transform TO Net Zero Strategy (which is under development and expected to be submitted to City Council at the end of 2021). While uncommitted initiatives as part of this draft strategy have not been accounted for in the demand forecast, these initiatives have the potential to further increase peak demand electricity use depending on the type of end use which is targeted. For example, electrification of transit, either public or private, can have a significant impact on electrical demand during late afternoons during summer, which coincides with when the transmission system is typically most constrained. Fuel switching for space heating, on the other hand, tends to have a larger impact during winter months, which are not typically as constraining for the transmission system in the GTA.

³ These forecasts include Dufferin TS. Only THESL loads are included in this graph.

3.2 Updated Conservation and Demand Management Assumptions

For the purposes of regional planning, conservation assumptions, including impacts of Codes and Standards, and CDM programs, are typically accounted for in two different ways. Firstly, the anticipated impacts of existing programs and the impacts of future committed programs which have been approved and funded are subtracted from the demand forecast to produce a net forecast which is used in the technical analysis of system performance. This ensures that identified system needs account for the anticipated impacts of committed conservation programs. Secondly, incremental cost-effective CDM potential, beyond committed programs as part of existing frameworks and policy is considered as part of the identification and evaluation of potential options to address needs. This section describes the way in which CDM has been built into the forecast; consideration of incremental cost-effective CDM as part of the identification and evaluation of options is discussed further in Section 4.1⁴.

In the 2019 IRRP, no adjustments were made to the demand forecast to account for future initiatives (e.g., CDM programs) because, at the time of IRRP development, conservation programs were being developed according to the Conservation First Framework, which was set to expire in 2020. As a result, information about future conservation initiatives, including targets and funding, was limited, and therefore future conservation assumptions were not accounted for.

Since publication of the 2019 IRRP, Ontario has released the 2021-2024 CDM Framework. For the purposes of this addendum, this framework has been the primary source of information to assist in developing assumptions about the future impact of provincially driven conservation savings. Anticipated impacts of conservation were developed on a station by station basis, and subtracted from the THESL forecast update to produce the final 2021 addendum forecast. The methodology used to develop these CDM assumptions is described in Appendix A.

The graph below in Figure 2 shows the original 2019 IRRP forecast, the updated forecast provided by THESL in 2020, and the final net 2021 addendum forecast used in the technical assessment of needs.

⁴ Note that impacts of previous programs (e.g., Conservation First Framework, Interim Framework) are inherently included in the forecast provided by THESL.

Figure 2 | Summer Coincident Peak Demand - 2021 Net Forecast

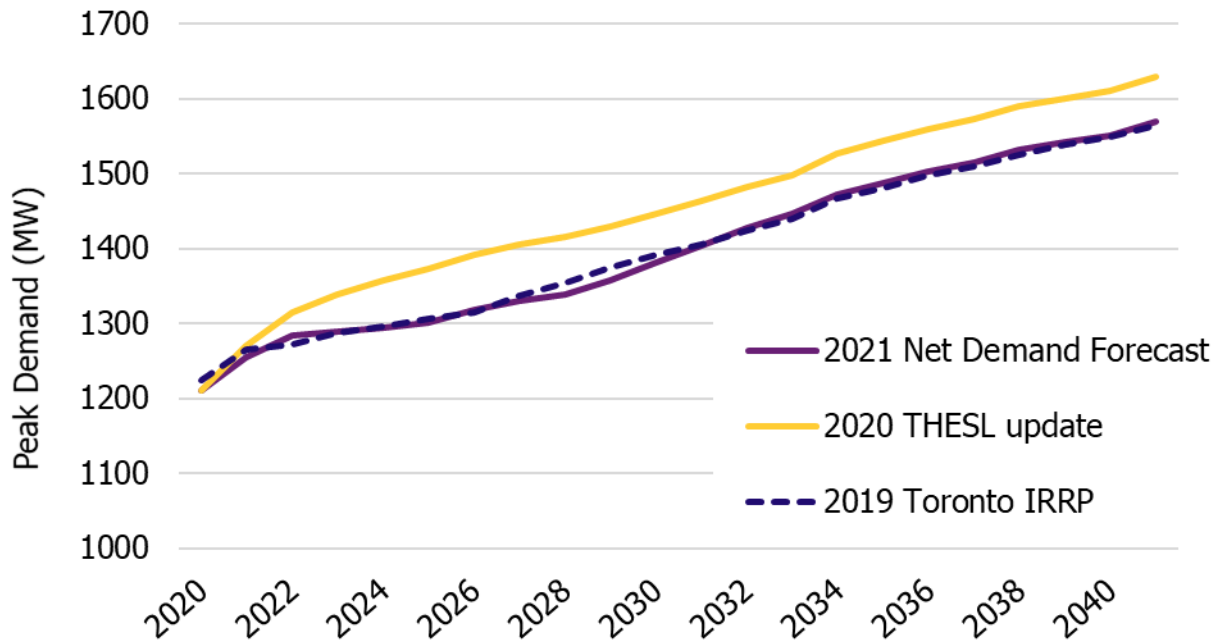

Note that the impact of the 2021-2024 CDM Framework largely offsets the additional demand growth observed in the first three to five years of the forecast. The end result is a final net demand forecast for the 2021 addendum that is similar to the 2019 IRRP demand forecast; the key difference is that the updated net demand forecast includes the impact of the 2021-2024 CDM Framework, whereas the forecast in the 2019 IRRP does not. There is also minimal impact on the forecast resulting from existing distributed generation.

3.3 Dufferin TS Supply

Dufferin TS is a step down transformer station located in central Toronto which typically peaks at approximately 125 MW. It has the ability to be served from either the Leaside sub-system, or the Manby sub-system (via the Richview x Manby corridor). While under normal operating conditions Dufferin TS is supplied via Leaside, operators have the ability to transfer Dufferin to Manby supply as an interim measure to manage periods of high demand on the Leaside sub-system, or as a result of system or resource outages which are impactful to the Leaside sub-system. Table 1 shows the historical use of this operational measure and increased use in recent years.

Table 1 | Table showing Percentage of Time Leaside loads are transferred to Manby and Manby Loads transferred to Leaside

	Leaside loads transferred to Manby		Manby loads transferred to Leaside	
	Percentage of year	Percentage of summer	Percentage of year	Percentage of summer
2018	2%	4%	2%	0%
2019	16%	0%	0%	0%
2020	31%	52%	2%	0%

One of the factors which has increased the frequency with which this measure is deployed is the removal of a bulk contingency exception on the Leaside TS x Cherrywood TS corridor in summer 2020, due to the broader bulk electricity system impacts from contingencies involving these facilities. Before the exemption was removed, operators did not need to respect the sudden loss of two circuits along this corridor⁵, as this event was not expected to impact the bulk power system outside of the Toronto area. Recent technical assessments have shown that this type of contingency can have a cascading impact on the broader bulk electricity system, including systems outside Ontario, under certain import conditions. As a result, operators must now ensure that at any time a sudden loss of two circuits will not cause this adverse impact. This becomes more likely as the load served by the Leaside sub-system increases, and particularly when Portlands GS or transmission assets are out of service pre-contingency. Transferring Dufferin TS to Manby supply lowers the amount of load served by the Leaside sub-system, and is therefore one way that operators can manage this condition.

Because transfer of Dufferin TS to Manby TS is not a standard operating condition, it has not been included as a basecase assumption in this addendum for the purposes of establishing system need. At the same time, given the frequency with which this action is taken, and the likelihood that it will remain a valuable tool for operators to maintain reliability in the future, it is strongly recommended that any solution to address the Richview x Manby supply capacity need be sized to ensure the continued viability of this action. Of particular interest, Hydro One has indicated that the use of this operating measure is expected to increase throughout the 2020s in order to accommodate outages required in the vicinity of Leaside TS to enable work on the Ontario Line transit project.

In other words, a solution that addresses the Richview x Manby capacity need must also be able to withstand the added load of supply to Dufferin TS. Otherwise, any solution would address one sub-system need (Manby), while introducing constraints to operator actions on a different sub-system (Leaside). In practical terms, this means that establishing the need

⁵ Regional Reliability Reference Directory #1: Design and Operation of the Bulk Power System, NPCC

date associated with Richview x Manby will be done assuming Dufferin supply via Leaside. However, when evaluating potential solutions to address this need, the required capacity will be considered under a Dufferin supply via Manby scenario.

3.4 Updated Contingencies Considered

A study to determine the load meeting capability (LMC) of the existing Richview by Manby corridor was conducted using the updated demand forecast and system topology assumptions. Additional technical details can be found in Appendix C.

The planning criteria applied in this study are in accordance with planning events and performance as detailed by:

- North American Electric Reliability Corporation ("NERC") TPL-001 "Transmission System Planning Performance Requirements" ("TPL-001"),
- Northeast Power Coordinating Council ("NPCC") Regional Reliability Reference Directory #1 "Design and Operation of the Bulk Power System ("Directory #1"), and
- IESO Ontario Resource and Transmission Assessment Criteria ("ORTAC").

Under these standards and requirements, and in this particular part of the system, load rejection/curtailment of up to 150 MW is permissible following the loss of two transmission elements. ORTAC does not specify a limit to the amount of load rejection/curtailment allowed following the loss of three or more elements so long as the load rejection/curtailment does not impact other areas outside the IESO controlled grid. For clarity, no load rejection/curtailment is allowed following the loss of one transmission element in this part of the system.

The following summarizes the critical single and double contingencies studied, consistent with NERC and NPCC planning events, for scenarios with all elements in-service and with one element initially out-of-service. In addition, this study considered the most limiting contingency of the existing system as identified by the Richview to Manby Reinforcement SIA (2018-637); namely the R24C + K23C double contingency following an R15K outage. This extra contingency was compared to the studied contingencies below to determine the LMC of the system.

The studied N-1 contingencies are:

- R1K
- R2K
- R13K
- R15K
- R24C

The studied N-2 contingencies are:

- R1K + R2K
- R13K + R15K

4 Updated Richview x Manby Needs Assessment

After accounting for updated system models and assumptions as described in Section 3, a needs assessment was carried out for the Richview x Manby corridor to produce a revised need statement. The limiting phenomenon observed continues to be loading on the R2K circuit following the loss of R15K and occurs in 2021. This contingency was limiting under the basecase scenario (an N-1 contingency), and the Dufferin supply from Manby scenario. Additional technical details can be found in Appendix C.

Table 2 shows the amount of peak demand forecast in excess of the load meeting capability of the corridor based on the limiting phenomenon. Also included is the original 2019 peak capacity need by year, for comparison:

Table 2 | Table showing the Richview x Manby Peak Demand Need in the 2019 IRRP vs. 2021 Addendum

Peak Demand (MW)	2021	2022	2023	2024	2025	2026	2027	2028	2029	2030
2019 IRRP Original Need										
2019 Supply Requirement	-	11	29	38	49	59	79	97	117	133
2021 Addendum Revised Need										
2021 Supply Requirement (Basecase)	1	24	35	48	58	77	90	102	119	142

Under basecase assumptions, needs have increased slightly compared to the original 2019 IRRP, largely as a result of higher than anticipated near term growth rates, as well as updates to the operational configuration of the system (operating Claireville and Richview buses as split). It is worth noting again that the revised needs include the impact of the 2021-2024 CDM Framework, while the 2019 IRRP did not have any CDM impacts included.

5 Updated Options Analysis

This section explores potential options that may assist in meeting the Richview x Manby corridor needs. These potential options include non-wires alternatives (NWAs), such as incremental CDM programs and other DER technologies, FACTS devices and the Richview x Manby transmission reinforcement. While this Addendum Study has considered non-wires alternatives, the primary focus is on incremental CDM programs in light of the updated information available with respect to this option through the Achievable Potential Study and the 2021-2024 CDM Framework. The feasibility of employing DERs and FACTS devices to meet the Richview x Manby corridor needs were not explicitly explored in the first cycle of regional planning for Toronto. In this addendum, DERs and FACTS devices are explored as part of the options analysis.

Given the importance of maintaining the capability to supply Dufferin TS from the Manby sub-system, as described in Section 3.3, the potential options have been evaluated against their capability to provide the required capacity including Dufferin TS.

5.1 Incremental CDM

In addition to the expected impact of conservation programs and savings embedded into the demand forecast (described in Section 3.1 above), the addendum also considered the potential for additional incremental CDM savings to target the Richview x Manby transmission corridor need. The potential for new CDM in the study area was developed by taking the 2019 Achievable Potential Study (APS)⁶, and scaling the results for the study area based on customer composition and peak demand. These values were further reduced to account for the savings already accounted for through the provincial 2021-2024 framework, which was not accounted for when the 2019 APS was developed. This produced an estimated incremental achievable cost effective potential for the area of 27 MW in 2025, and 121 MW in 2030. Table 3 shows the expected cumulative CDM potential, by year. Note that these savings forecasts are estimates and can be further refined as programs are developed to target local CDM opportunities.

⁶ 2019 Conservation Achievable Potential Study (<https://www.ieso.ca/2019-conservation-achievable-potential-study>)

Table 3 | Incremental Cost Effective Achievable CDM Potential

	2022	2023	2024	2025	2026	2027	2028	2029	2030
Incremental Cost Effective Achievable CDM Potential (MW)⁷	3	7	14	27	44	61	78	100	121
Local Incentive Program Target (MW)	2.8	5.4	8	8	8	-	-	-	-

Although the anticipated amount of incremental achievable cost effective CDM in the study area is insufficient to fully meet the supply capacity need under either the basecase and Dufferin TS supply from Manby scenarios (refer to Table 2), this option can still be leveraged in two ways:

- Incremental cost effective achievable CDM may be considered with other options which may, together, fully meet the need, and;
- Incremental cost effective achievable CDM will help lower customer exposure to reliability risk by reducing the number of hours and/or magnitude of need when peak demand is expected to exceed planning ratings. This could be particularly useful in mitigating risk before other solutions can come into service given their lead time.

One program that has recently been developed to target some of this potential in the Richview south area is the Local Initiative Program, or LIP. As part of the 2021-2024 Conservation and Demand Management CDM Framework, the LIP will develop local initiatives to deliver CDM savings in targeted areas of the province with identified system needs. Under this program, up to 8 MW (out of a total 44 MW in Table 3 above) is expected to be achieved in the study area by 2026. Additional information on this program is available on the IESO website⁸. It should be noted that alternate mechanisms would be needed to acquire remaining portion of incremental cost effective achievable CDM beyond the LIP.

This section does not include a cost evaluation of the CDM measures (whether it be from 2021-2024 CDM Framework or the LIP) as they are considered to be committed by way of Ministerial directive, and, as such, already passed a system cost-effectiveness test. While the remaining portion of the incremental cost effective achievable CDM is not committed, it has been determined to be cost effective from a system perspective.

⁷ Note that this potential includes the funded Local Initiative Program and as of yet unfunded CDM potential

⁸ Save on Energy, Local Initiatives <https://saveonenergy.ca/en/For-Business-and-Industry/Programs-and-incentives/Local-Initiatives>

5.2 Distributed Energy Resources

Distributed Energy Resources, or DERs, are a range of technologies which work by meeting system capacity needs locally. They include numerous technologies including, but not limited to, solar PV, energy storage, behind-the-meter generation, and demand response. They provide an alternate source of electricity, thereby reducing the electricity demanded from the grid and alleviating the strain on the electricity system. The Addendum Study has reviewed DER options in this context, to ensure there are no significant changes that would change the ability of DERs to defer the needs.

The study team considered the amount of DER required to defer the Richview x Manby transmission reinforcements (the status quo recommendation from the 2019 IRRP) from its anticipated in-service date of 2025 to 2030. This assumption balances the lead-time of the transmission reinforcement with the capacity of DER required in the specific Richview South area. No DER costs are included between 2021 and 2024 as they will impact all options equally (given the anticipated in-service dates of the other options) and are thus not required for comparison of the options.

The maximum annual capacity required by DER solutions to fully address the system capacity need was informed by the net peak demand forecast used in this addendum and assumes that all incremental cost effective achievable CDM is acquired first. Additionally, a sample load duration profiles was developed in order to estimate the number of cumulative hours and total energy required for each event when the net peak load exceeds the LMC of the Richview x Manby transmission corridor. Details on how these load profiles were developed are provided in Appendix B. Taken together, the annual capacity, duration and energy requirements help to identify which DER technologies are technically capable of meeting the need.

Because the need identified in the Richview South area occurs during summer peak conditions, only DERs which are able to dispatch when required during late summer afternoons are considered technically feasible. Consideration was given to the following resource types:

- Resources that have cost and operating characteristics equivalent to a Simple Cycle Gas Turbine (SCGT); any other mention of SCGT in the report is meant in this context.
- Battery Storage - This technology works by charging during periods when electricity is less costly and the system is not constrained (such as overnight), and discharging during peak conditions when the need occurs.
- Demand Response (DR)- This technology relies on customers within the target area reducing their net demand (through load shifting, curtailment, or behind-the-meter generation) when a signal is received.

As shown in the table above, the amount of DERs required, in addition to all incremental cost effective achievable CDM, is significant, particularly to accommodate Dufferin TS transfers. The technical working group ruled out further consideration of DERs on this basis as further described below.

- An SCGT of this magnitude is unlikely to be feasible to site in the specific Richview South area and would cost orders of magnitude more than other solutions.
- Battery energy storage is also unlikely to be feasible when considering the characteristics of the need and current battery technology and costs.
- Demand response is not considered a feasible means of meeting the need, particularly considering Dufferin TS transfers, given that peak demand offsets would be equivalent to around 15% of total peak load being curtailed in the specific Richview South study area. In addition, based on the results from the 2020 Capacity Auction the total additional potential for DR in the Toronto Zone (i.e., wider Greater Toronto Area) is approximately 186 MW. In order to meet the supply capacity need, approximately 170 MW (assuming also that all incremental cost effective achievable CDM is acquired) of this potential would need to be achieved annually in the specific Richview South area.

5.3 FACTS Devices

Flexible AC Transmission System (or FACTS devices) are a broad category of electrical equipment which can be used to dynamically control voltages within the system, and influence how power flow is distributed across multiple circuits. In the case of Richview South, system needs are driven by flow along the limiting Richview x Manby corridor. A separate circuit in the area, i.e., Richview x Cooksville (R24C), is not as heavily loaded during typical summer peak conditions and presents an opportunity to offload the Richview x Manby corridor if power could be diverted to this circuit. One particular type of FACTS device, Static Synchronous Series Capacitors (SSSCs), has been evaluated for technical feasibility and cost considerations for this application. SSSCs work by injecting a voltage in series with the line, which introduces an inductive or capacitive reactance and influences the share of power which will flow through that circuit, compared to other parallel routes.

This analysis was undertaken by Smart Wires Inc., a technology company with experience in building and installing SSSCs devices.

The basecase model developed for the addendum was used to evaluate performance of the SSSC device following the same limiting contingencies observed for the loss of R15K, with and without the Dufferin TS supply scenario from the Manby system. A three phase installation of SSSCs were assumed to be installed along the less utilized R24C circuits, to carry additional power flows which would otherwise flow along, and exceed planning limits of, R2K. This is shown conceptually with sample flows and ratings in Figure 3.

Figure 3 | Diagram showing most limiting contingency and element and proposed location of SSSC technology (Source: Smart Wires Inc.)

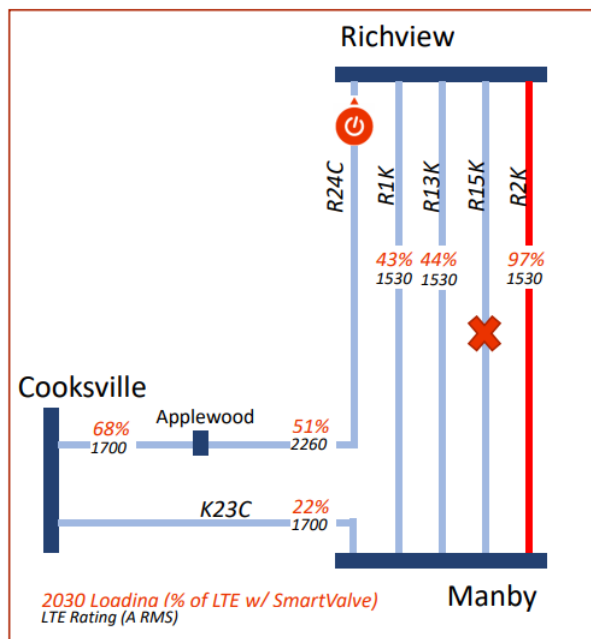

Based on the evaluation carried out, the SSSC device would defer the supply capacity need up to approximately 2028 with Dufferin TS supplied by Manby, after which, the Richview x Manby transmission reinforcements would be required. Although all relevant performance criteria would be met under this alternative up until 2028, this solution would require the use of Load Rejection (L/R) under certain contingencies, such as the loss of two circuits mentioned in Section 3.4. This is considered an acceptable practice under established planning criteria to recognize the relatively low probability of multi-order contingencies occurring at the same time as high system loading, however this has been cited as a concern by THESL which has expressed its preference for solutions that reduce the likelihood of implementing load rejection for dense urban areas.

The SSSC facilities could be deployed within one year of the equipment order, at a cost approximately \$4-6 M, with ongoing annual maintenance costs of around \$50,000-80,000. However, additional costs, time, and considerations are required to ensure a suitable location exists to accommodate this type of facility. Hydro One has indicated that given the maximum short circuit rating of the SSSC equipment (68 kA), it would have to be installed some distance from Richview TS (where equipment must accommodate short circuit ratings of 70 kA). This would mean finding a suitable location along the R24C corridor between Richview TS and Cooksville TS, and designing and constructing a fenced in facility with Environmental Assessment (EA) approvals, protections, control, and telemetry equipment.

Using the timeline and costs for building similar facilities within the GTA, Hydro One estimated that the necessary development costs would add approximately \$6-8 M to the

SSSC equipment, and could be completed within approximately 30 months. The facility itself would also take up significant space in the existing right of way, and could introduce a risk of community opposition as a result. Delays with the EA process could also potentially add a year or more to the project timeline, depending on the level of involvement and whether a full class EA is triggered.

Additional concerns have also been raised regarding timelines for detailed engineering evaluation and approval for the use of SSSC, given that this technology has not been used in Ontario before. Both Hydro One and the IESO would require a detailed review of this technology and its performance characteristics before it could be approved for connection to Hydro One facilities or the interconnected grid. These concerns include dynamic performance of the technology under fault conditions, and testing of equipment at low temperatures.

Hydro One has indicated that testing of new technology may add additional time to the approvals process before development can be undertaken. The total cost and timeline of the Smart Wires solution is estimated at least \$10.5 M, with an earliest in-service date of 2025. The total NPV cost of this option, including the cost of the Richview x Manby transmission reinforcements which would be required by 2029, is approximately \$32 M.

5.4 Richview x Manby Transmission Reinforcement

The transmission based solution studied in this addendum is the same solution initially recommended in the 2019 IRRP; that is rebuilding an idle 115 kV double circuit line as a 230 kV double circuit line. This is outlined in the proposed Richview TS by Manby TS upgrades as found in the System Impact Assessment (SIA) Report ID 2018-637.

According to the SIA Report, the RxK upgrades involves the following:

- The existing idle 115 kV line between Richview TS and Manby TS will be rebuilt as a new 230 kV double circuit line, with both circuits tied together to form one super-circuit. The new 230 kV super-circuit will take the breaker positions of the existing circuit R15K at both ends and be designated as circuit R15K.
- The existing circuit R15K will be re-connected at both ends, taking the breaker positions of the existing circuit R1K and renamed R1K.
- The existing R1K and R2K circuits will be bundled as one new super-circuit R2K, taking the breaker positions of the existing R2K at both ends.
- The Horner TS tap point on the existing R13K circuit will be moved onto the new circuit R15K.
- The existing last section of K21C of nine meters connected to Cooksville TS will be upgraded. The long-term thermal rating of the new line section will be at least 2000 Amps.

Based on the study results found in Appendix D, under the updated demand forecast, it is found that the most limiting contingency will not result in any violations of planning criteria. Load rejection up to 350 MW may be required under certain scenarios (i.e. when three elements are out of service on the Richview South area) which is still acceptable under applicable planning criteria. Therefore, it is expected that the proposed transmission solution can meet the demand as forecasted in the Toronto IRRP addendum up to the end of the study period in 2040. Based on current estimates from Hydro One, the upgrade would be complete by Q2 2025 and will cost approximately \$23 M (NPV) assuming development work begins immediately.

6 Revised Planning Outcomes

After completing the revised needs statement, a review of technically feasible options was undertaken using updated assumptions, particularly related to incremental cost effective achievable CDM. A preferred solution was identified on the basis of technical feasibility, cost, and ability to fully meet system needs over the long term. The results of this assessment are included in Section 6.1 below.

It is also recognized that the urgency of this system need, coupled with the expected timeline to implement the preferred solution, will result in a multi-year period in which loads in the Richview South area may be at increased risk of experiencing lowered reliability. Optional measures to mitigate this risk, including activities already underway, are explored in Section 6.2.

6.1 Preferred Solution

Based on the updated review of system needs associated with the Richview x Manby transmission corridor and evaluation of options to address this need, the transmission upgrade option continues to be the preferred option to address system capacity needs in the Richview South area. A transmission upgrade, including rebuilding an idle 115 kV double circuit line to 230 kV, and associated connection work at Richview TS and Manby TS, with an expected in-service date of 2025 is the only solution which is able to meet needs associated with anticipated load growth over the medium and long term at the lowest cost to Ontario ratepayers. A summary of the economic assumptions and results can be found in Appendix E.

By providing a significant increase in both supply meeting capability and customer reliability, this solution is also the only alternative that will allow for the continued transfer of Dufferin TS to the Manby system beyond 2028 while still respecting standard planning criteria and ratings. Based on the updated load forecast, the need for this transmission upgrade is present day. Notably, the transfer of Dufferin TS during peak summer conditions have already caused the load meeting capability of the Richview x Manby corridor to be exceeded during summer peak in 2020, when considering planning criteria⁹. The frequency with which this event occurs is expected to increase throughout the 2020s as a result of continued forecast growth throughout Toronto, as well as increased operator transfers of Dufferin TS to Manby supply to accommodate outages associated with the construction of the Ontario Line.

⁹ Note that the limiting contingency (loss of R15K) did not occur in 2020. It was a risk of the need materializing when considering planning ratings.

It is therefore recommended that Hydro One immediately proceed with work on this project targeting an in-service date of 2025. Note that the technical working group understands this is the earliest possible in-service date given the project lead time.

Use of SSSCs has the potential to meet the needs until approximately 2028 with Dufferin TS transferred to Manby. However, when compared to a transmission solution, this option will be more expensive and would expose customers to greater potential levels of load rejection under certain contingencies (though still within acceptable ranges under established criteria). Additionally, potential delays associated with study and approval of a technology untested in Ontario would add additional time and uncertainty to implement this solution, while costs associated with building a site suitable for accommodating this technology would add both costs and risk from a project planning perspective. For these reasons, an SSSC is not recommended as a solution in this application.

6.2 Potential Mitigation Measures Before Implementation of Preferred Solution

As discussed above, this addendum has validated the need for transmission upgrades of the Richview x Manby corridor to meet anticipated near term supply capacity needs in the Richview South area. However, due to the anticipated timelines associated with design, approvals, and construction of this project, it is unlikely to be in service until summer of 2025, even though need is present day. As a result, even if the recommended actions are pursued, customers in the Richview South area remain exposed to greater reliability risks than permitted under standard planning criteria for the next three to four years.

The periods of time where load may be at risk following a single element outage can emerge when load served by the Richview x Manby corridor exceeds its LMC. Any measure which is able to reduce customer demand during summer hours would lower the amount of load which could potentially be at risk of interruption by an equal amount. In other words, any decrease in load above the LMC would carry a reliability benefit, even if it is not able to keep loads below this threshold entirely.

However, quantifying the value of this reliability benefit is challenging, as there is no associated transmission deferral. Instead, it is recommended that NWA be considered within the context of broader provincial supply and demand needs, and be prioritized in the Richview South area and pursued where cost effective. Among the NWA considered in this addendum, both CDM and DR have the potential to lower exposure to customer reliability needs until the transmission upgrade can come into service, and may be cost effective from a system benefit perspective.

In the case of CDM, the Local Initiatives Program will identify and procure cost effective opportunities in the Richview South area. Targeting spending in areas with known reliability benefit or local deferral value is consistent with the objectives laid out in the 2021-2024

Conservation Framework. More information on this initiative is available on the IESO website.¹⁰

There is opportunity to leverage THESL's flagship Non-Wires Alternatives program, Local Demand Response (DR), which has been deployed successfully since 2018. Local DR is a big step forward in evolving conventional utility station planning to include the consideration of non-wires alternatives alongside traditional poles and wires investments. This program is designed to help address short-to-medium term capacity constraints at targeted transformer stations by identifying opportunities where behind-the-meter, customer-owned DERs, can be leveraged to support the broader distribution system cost-effectively. The 2020-2024 Local DR program will target three station areas, including Basin TS, Manby TS, and Horner TS, with the goal of competitively procuring up to 17 MW of DR capacity to be deployed in 2022. This program supports broad regional planning goals and provides the opportunity to realize benefits at both the distribution level and the transmission level in the Richview south area.

¹⁰ Save on Energy, Local Initiatives <https://saveonenergy.ca/en/For-Business-and-Industry/Programs-and-incentives/Local-Initiatives>

**Independent Electricity
System Operator**

1600-120 Adelaide Street West
Toronto, Ontario M5H 1T1

Phone: 905.403.6900

Toll-free: 1.888.448.7777

E-mail: customer.relations@ieso.ca

ieso.ca

 [@IESO_Tweets](https://twitter.com/IESO_Tweets)

 facebook.com/OntarioIESO

 linkedin.com/company/IESO

Toronto Region: Integrated Regional Resource Plan

August 9, 2019

Toronto Region

Integrated Regional Resource Plan

This Integrated Regional Resource Plan (IRRP) was prepared by the Independent Electricity System Operator (IESO) pursuant to the terms of its Ontario Energy Board license, EI-2013-0066.

The IESO prepared the IRRP on behalf of the Toronto Regional Planning Working Group (Working Group), which included the following members:

- Independent Electricity System Operator
- Toronto Hydro-Electric System Limited (Toronto Hydro)
- Hydro One Networks Inc. (Hydro One)

The Working Group developed a plan that considers the potential for long term electricity demand growth and varying supply conditions in the Toronto region, and maintains the flexibility to accommodate changes to key conditions over time.

Table of Contents

1. Introduction	1
2. Summary of the Recommended Plan	4
2.1 The Plan	4
3. Development of the Plan	7
3.1 The Regional Planning Process	7
3.2 Toronto Region Working Group and IRRP Development	7
4. Background and Study Scope	9
4.1 Study Scope	10
5. Peak Demand Outlook	14
5.1 Demand Outlook Methodology	14
5.2 The Outlook for Energy Efficiency	15
5.3 Outlook for Distributed Energy Resources	16
6. Power System Needs	18
6.1 Needs Assessment Methodology	18
6.2 Power System Needs	19
6.2.1 End-of-life Asset Replacement Needs	19
6.2.2 Supply Capacity Needs	28
6.2.3 Load Security Needs	37
6.2.4 Load Restoration Needs	37
6.2.5 Discretionary Reliability Needs	38
6.2.6 System Resilience for Extreme Events	39
6.3 Summary of Needs Identified	40
7. Plan Options and Recommendations	42
7.1 Evaluating Plan Options for Addressing Needs Identified in Toronto	43
7.1.1 Options for Addressing End of Life Asset Replacement	44
7.2 Options for Addressing Supply Capacity Needs	51
7.3 Options for Addressing Regional Supply Capacity Needs	53
7.4 Options for Addressing Discretionary Reliability Needs	54
7.5 The Recommended Plan	54
7.5.1 Implementation of Recommended Plan	56

8. Community and Stakeholder Engagement	59
8.1 Engagement Principles	59
8.2 Creating an Engagement Approach	60
8.3 Engage Early and Often.....	60
8.4 Outreach with Municipalities.....	61
9. Conclusion.....	62

List of Figures

- Figure 1-1: Location of the Toronto Region..... 2
- Figure 4-1: The Regional Transmission System Supplying Toronto 12
- Figure 4-2: The Toronto Region Electrical System (Single-Line Diagram) 13
- Figure 6-1: Leaside to Bloor Street Junction 115 kV Overhead Transmission Lines 21
- Figure 6-2: Leaside to Balfour 115kV Overhead Transmission Lines..... 22
- Figure 6-3: Location of Main TS..... 23
- Figure 6-4: C5E/C7E 115 kV Underground Transmission Cables..... 24
- Figure 6-5: Location of Manby TS..... 25
- Figure 6-6: Location of John TS 26
- Figure 6-7: Location of Bermondsey TS..... 27
- Figure 6-8: Location of Local (Transformer Station) Capacity Needs 29
- Figure 6-9: Demand Outlook for Strachan TS DESNs Compared to Capacity 30
- Figure 6-10: Demand Outlook for Basin TS DESN Compared to Capacity..... 31
- Figure 6-11: Demand Outlook for Leslie TS Compared to Capacity 32
- Figure 6-12: Demand Outlook for Wiltshire TS DESN Compared to Capacity 34
- Figure 6-13: Load Restoration Criteria..... 38
- Figure 9-1: IESO Engagement Principles..... 59

List of Tables

Table 4-1: Summary of Station Facilities (230 kV and 115 kV) 10

Table 4-2: Summary of Transmission Circuits (230 kV and 115 kV) 11

Table 5-1: Estimated Peak Demand Savings from Codes and Standards 16

Table 6-1: Toronto Region End-of-life Asset Replacement Needs (Near term) 20

Table 6-2: Toronto Region End-of-life Asset Replacement Needs (Medium term) 23

Table 6-4: Load Security Criteria 37

Table 6-5: Summary of Needs Identified 40

Table 7-1: Options for Addressing Leaside Junction to Bloor Street Junction 115 kV Lines 45

Table 7-2: Options for Addressing Leaside TS to Balfour Junction Transmission 46

Table 7-3: Options for Addressing Main TS End-of-life Assets 48

Table 7-4: Summary of Needs and Recommended Actions in Toronto Region 57

List of Appendices

- Appendix A: Overview of the Regional Planning Process
- Appendix B: Peak Demand Outlook for Toronto 2017-2041
- Appendix C: Energy Efficiency Forecast
- Appendix D: Toronto IRRP Study Results
- Appendix E: Station Capacity Assessment
- Appendix F: Richview TS to Manby TS Corridor Needs Study
- Appendix G: Responses to Public Feedback on Proposed Recommendations

List of Acronyms

Acronym/ Alternative	Description
CHP	Combined Heat and Power
DER	Distributed Energy Resource
DESN	Dual Element Spot Network
DR	Demand Response
EA	Environmental Assessment
FIT	Feed-in Tariff
GTA	Greater Toronto Area
Hydro One	Hydro One Networks Inc.
IESO	Independent Electricity System Operator
IRRP	Integrated Regional Resource Plan
kV	Kilovolt
LAC	Local Advisory Committee
LDC	Local Distribution Company
LMC	Load Meeting Capability
LTE	Long-term Emergency Rating
LTR	Limited Time Rating
MVA	Mega Volt Ampere
MW	Megawatt
NWA	Non-wires Alternative
OEB	Ontario Energy Board
ORTAC	Ontario Resource and Transmission Assessment Criteria
PEC	Portlands Energy Centre
PV	Photo-voltaic (Solar)
RAS	Remedial Action Scheme
RIP	Regional Infrastructure Plan
SS	Switching Station

Acronym/ Alternative	Description
STE	Short-term Emergency Rating
Toronto Hydro	Toronto Hydro-Electric System Limited
TPSS	Traction Power Sub-station
TS	Transmission Station or Transformer Station
Working Group	Technical Working Group for Toronto Region IRRP

1. Introduction

This Integrated Regional Resource Plan (IRRP) addresses the regional electricity needs for the City of Toronto (Toronto region) between 2019 and 2040.¹ This report was prepared by the Independent Electricity System Operator (IESO) on behalf of a Working Group comprising the IESO, Toronto Hydro-Electric System Limited (Toronto Hydro), and Hydro One Networks Inc. (Hydro One).

In Ontario, planning to meet the electrical supply and reliability needs of a large area or region is carried out through regional electricity planning, a process that was formalized by the Ontario Energy Board (OEB) in 2013. In accordance with this process, transmitters, distributors and the IESO are required to carry out regional planning activities for 21 electricity planning regions across Ontario, at least once every five years. The Toronto region, shown in Figure 1-1, corresponds with the municipal boundaries of the City of Toronto. Other electricity planning regions adjacent to the Toronto region include Greater Toronto Area (GTA) West, GTA East, and GTA North.

¹ The planning horizon year is 2040: the different time frames within the plan period include the near term (up to five years out); medium term (six to 10 years out); and long term (11 to 20 years out).

Figure 1-1: Location of the Toronto Region

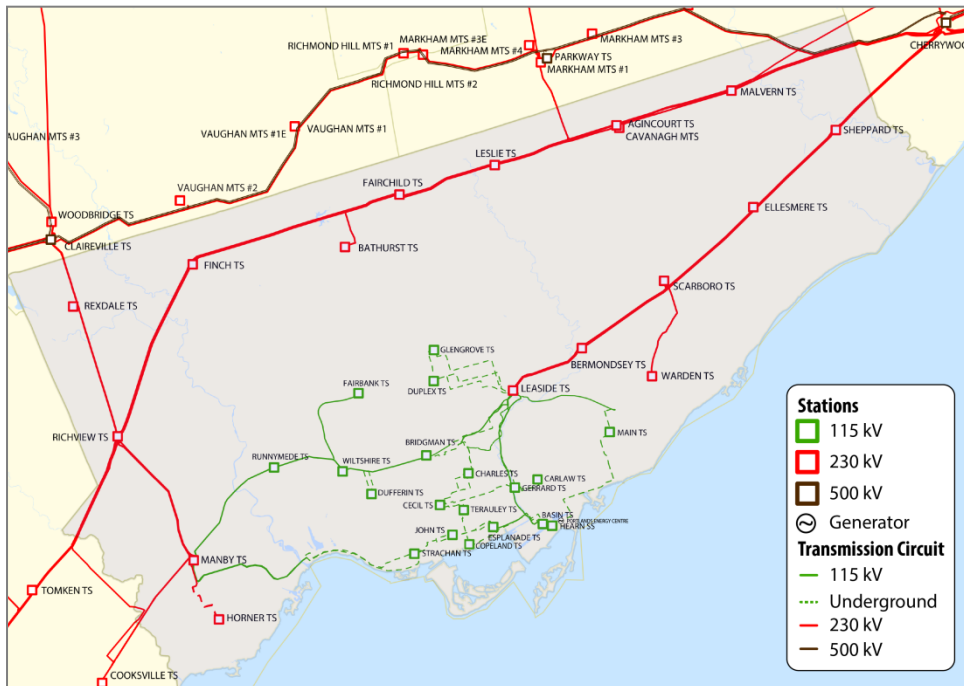

This IRRP reaffirms the needs and plans previously identified in the Metro Toronto Regional Infrastructure Plan (RIP) published in January 2016, and the Needs Assessment report completed in 2017. It identifies new capacity and reliability needs of the electric transmission system, and recommends approaches to ensure that Toronto’s electricity needs can be met over the planning horizon. Specifically, the plan recommends approaches for addressing a number of end of life asset replacement needs and potential longer-term capacity needs to accommodate growth and city development.

For needs that may emerge in the longer term (11 to 20 years out), the plan maintains flexibility for new solutions. As the long term needs highlighted by the technical studies are subject to uncertainty related to future electricity demand and technological change, this IRRP does not recommend specific investments to address them at this time.

The plan identifies some near term actions to monitor demand growth, explore possible long term solutions, engage with the community, and gather information to lay the groundwork for determining options for future analysis. The near term actions recommended are intended to be completed before the next regional planning cycle, scheduled for 2024 or sooner, depending on demand growth or other factors that could trigger early initiation of the next planning cycle.

This report is organized as follows:

- A summary of the recommended plan for the Toronto region is provided in Section 2;
- The process and methodology used to develop the plan are discussed in Section 3;
- The context for regional electricity planning in the Toronto region and the study scope are discussed in Section 4;
- The demand outlook scenarios, and energy efficiency and distributed energy resource (DER) assumptions, are described in Section 5;
- Electricity needs in the Toronto region are presented in Section 6;
- Options and recommendations for addressing the needs are described in Section 7;
- A summary of engagement activities to date, and moving forward, is provided in Section 8; and
- A conclusion is provided in Section 9.

2. Summary of the Recommended Plan

The recommendations in this IRRP are focused on replacement of assets at their end of life, and preparing to address local and regional capacity needs emerging in the longer term.

The successful implementation of the recommended actions summarized below is expected to address the region's electricity needs until at least the late 2020s.

2.1 The Plan

This plan re-affirms the needs and plans identified in the previous regional planning cycle that concluded in January 2016, and recommends the actions described below to address the region's transmission needs until at least the late 2020s or early 2030s.

The recommendations set forth in this plan are summarized as follows:

Replace end of life overhead line sections H1L/H3L/H6LC/H8LC and L9C/L12C

The Working Group recommends that Hydro One proceed with planning for the like for like replacement of these overhead line sections.

Replace end of life transformers at Main TS

The Working Group recommends that Hydro One proceed with planning to replace the existing transformers with 60/100 MVA transformers.

Continue planning for replacement of C5E/C7E underground transmission cables

The Working Group recommends that Hydro One continue planning to replace the existing cables.

Continue planning to determine end of life approaches for Manby TS, John TS, and Bermondsey TS

Manby TS and John TS: The Working Group recommends that detailed planning for end of life of these assets continue, starting with the RIP.²

Bermondsey TS: The Working Group recommends that the plan to replace the two end of life transformers at Bermondsey TS be completed within the scope of the RIP.

Gather information to inform future capacity planning for Basin TS

Since there is currently insufficient information to characterize the needs at Basin TS and inform specific recommendations in this IRRP, the Working Group proposes that any recommendation on potential solutions be deferred until the next cycle of regional planning, or earlier, as required.

Specifically, the Working Group recommends that Toronto Hydro coordinate continued planning activities related to defining the nature, scope and timing of the future capacity need at Basin TS, and assessment of possible wires and non-wires alternative (NWA) solutions to address the need.

Proceed with reinforcement of the Richview TS to Manby TS 230 kV corridor

The Working Group recommends that Hydro One proceed with the reinforcement of the Richview TS to Manby TS 230 kV corridor and begin community engagement, as well as initiate the environmental assessment (EA).

Keep options available to address long term regional supply capacity needs

For the longer-term regional capacity needs, including the Leaside TS and Manby TS autotransformers, Manby TS to Riverside Junction lines, and Bayview Junction to Balfour Junction circuit section, the Working Group recommends that the IESO coordinate continued planning work and engagement with stakeholders and the community to:

- Define and communicate, as soon as practicable, the longer-term capacity needs

² The RIP is described in Section 3.1.

- Identify opportunities for a range of cost-effective solutions, including NWAs such as DERs and energy efficiency
- Identify potential wires solutions and avoidable costs should these needs be deferred through NWAs

The information and insights developed through these activities will be used to inform the next regional planning cycle.

3. Development of the Plan

3.1 The Regional Planning Process

In Ontario, planning to meet an area's electricity needs at a regional level is completed through the regional planning process, which assesses regional needs over the near, medium, and long term, and develops a plan to ensure cost-effective, reliable electricity supply. A regional plan considers the existing transmission electricity infrastructure in an area, local supply resources, forecast growth and area reliability; evaluates options for addressing needs; and recommends actions to be undertaken.

The current regional planning process was formalized by the OEB in 2013, and is conducted for each of the province's 21 electricity planning regions by the IESO, transmitters and local distribution companies (LDCs) on a five-year cycle.

The process consists of four main components:

- 1) A needs assessment, led by the transmitter, which completes an initial screening of a region's electricity needs;
- 2) A scoping assessment, led by the IESO, which identifies the appropriate planning approach for the identified needs and the scope of any recommended planning activities;
- 3) An IRRP, led by the IESO, which identifies recommendations to meet needs requiring coordinated planning; and/or
- 4) An RIP led by the transmitter, which provides further details on recommended wires solutions.

More information on the regional planning process and the IESO's approach to regional planning can be found in Appendix A: Overview of the Regional Planning Process.

3.2 Toronto Region Working Group and IRRP Development

Development of the Toronto region IRRP was initiated in late 2017 with the release of a needs assessment prepared by Hydro One on behalf of the Toronto Regional Planning Working Group comprised of the IESO, Toronto Hydro, Alectra Utilities, Veridian Connections (now elexicon energy) and Hydro One Distribution. The report identified transmission needs that may require coordinated planning in the Toronto region, with needs limited to the electrical system within the municipal boundaries of the City of Toronto.

Subsequent to the [Needs Assessment Report](#), the IESO prepared a [Scoping Assessment Outcome Report](#), which recommended that an IRRP be undertaken to address a number of needs, owing to the potential for coordinated solutions. No sub-regions were identified for the purpose of carrying out this IRRP. Given the location of the needs identified, the IRRP Working Group was determined at the scoping assessment stage to include the IESO, Toronto Hydro and Hydro One.³

In 2018, the Working Group began gathering data, conducting assessments to identify near term to long term needs in the area, and recommending actions to address Toronto's electricity transmission needs.

³ Distribution system planning does not fall within the scope of a regional planning study, though regional plans may inform distribution system plans. Distribution system plans are undertaken by local distribution companies and reviewed and approved by the OEB under a separate process.

4. Background and Study Scope

This is the second cycle of regional planning for the Toronto region. When the OEB formalized the regional planning process in 2013, planning was already underway in the Central Toronto area, a sub-region of Toronto that includes the downtown core. As such, Central Toronto became one of the Group 1 planning regions, and the first to participate in the formalized regional planning process.

The first cycle of regional planning for the Toronto region was completed in January 2016 with the publication of Hydro One's RIP for the Central Toronto area. Subsequent to the completion of an IRRP for Central Toronto (in April 2015), the IESO published an update to the IRRP that accounted for plans to convert commuter heavy rail in the GTA from diesel to electric power.

The second cycle of regional planning for Toronto was initiated by Hydro One in mid-2017. Following publication of a needs assessment in October 2017, a scoping assessment, released in February 2018, identified a number of needs requiring further regional coordination, and recommended that an IRRP for the Toronto region be initiated. No sub-regions within Toronto were recommended for this IRRP.

Building on past regional studies and taking into account updates to activities, including investments in electricity infrastructure and Toronto Hydro's long term outlook for electricity, this IRRP focuses on:

- Identifying recommendations for replacing assets that are reaching end of life
- Supporting and enabling growth and planned urban development
- Maintaining a high level of reliability performance

To set the context for this IRRP, the scope of the planning study and the area's existing electricity system are described in Section 4.1.

4.1 Study Scope

This IRRP, prepared by the IESO on behalf of the Working Group, recommends options to meet the regional electricity needs of the Toronto region. Guided by the principle of maintaining an adequate level of reliability performance as per the *Ontario Resource and Transmission Assessment Criteria* (ORTAC), this study recognizes the importance of electricity service to the functioning of a large urban centre. The [Toronto Region Scoping Assessment Outcome Report](#) established the objectives, scope, roles and responsibilities, and timelines for this IRRP. The plan considers the long term outlook for electricity peak demand, energy efficiency, and transmission system capability and transmission asset condition. Options for addressing needs also considered relevant transmission and distribution system projects and capabilities, community plans, and distributed energy resources (DERs).

The transmission facilities that were included in the scope of this study are presented in Table 4-1 (stations) and Table 4-2 (circuits).

Table 4-1: Summary of Station Facilities (230 kV and 115 kV)

Leaside 115 kV	Manby 115 kV	East 230 kV	North 230 kV	West 230 kV
Basin TS	Copeland TS	Bermondsey TS	Agincourt TS	Horner TS
Bridgman TS	Fairbanks TS	Ellesmere TS	Bathurst TS	Manby TS ³
Carlaw TS	John TS	Leaside TS ⁴	Cavanagh TS	Rexdale TS
Cecil TS	Runnymede TS	Scarboro TS	Fairchild TS	Richview TS
Charles TS	Strachan TS	Sheppard TS	Finch TS	
Dufferin TS	Wiltshire TS	Warden TS	Leslie TS	
Duplex TS			Malvern TS	
Esplanade TS				
Gerrard TS				
Glengrove TS				
Main TS				
Terauley TS				
Hearn SS ⁵				

⁴ Includes the step-down transformers and 230/115 kV autotransformers

⁵ Hearn Switching Station (SS)

Table 4-2: Summary of Transmission Circuits (230 kV and 115 kV)

230 kV	115 kV	
C10A	C5E	K11W
C14L	C7E	K12W
C15L	D11J	K13J
C16L	D12J	K14J
C17L	D6Y	K1W
C20R	H10DE	K3W
C2L	H11L	K6J
C3L	H12P	L12C
C4R	H13P	L13W
R1K	H14P	L14W
R2K	H1L	L15
R13K	H2	L16D
R15K	H2JK	L18W
R24C	H3L	L2Y
K21C	H6LC	L4C
K23C	H7L	L5D
	H8LC	L9C
	H9DE	

Transmission supply is provided to Toronto Hydro from 35 step-down transformer stations that are supplied by transmission voltages operating at either 230 kV or 115 kV. Toronto Hydro delivers electricity from these transmission supply points to its customers through its own electricity distribution system. Eighteen 230 kV step-down transformer stations supply the eastern, western and northern parts of Toronto (18 of these stations supply 27.6 kV voltage and two also supply 13.8 kV electricity to the distribution system); and 17 115 kV step-down stations supply the Central Toronto area (15 at 13.8 kV and two at 27.6 kV on the distribution side). The supply to these central 115 kV stations comes from two 230 kV/115 kV autotransformer stations (Leaside TS and Manby TS). The Toronto region also includes the Portlands Energy Centre (PEC) connected to the 115 kV transmission system (within the Leaside TS sector). The PEC 550 MW combined-cycle power plant plays an important role locally, and for the provincial electricity system, in providing reliable capacity to meet electricity demand, as well as reactive power and voltage support. Hearn SS provides 115 kV switching facilities for the Leaside area and also connects PEC to this system.

The Toronto region and its transmission supply infrastructure are shown in Figure 4-1 (map) and Figure 4-2 (single line diagram). Transmission circuit nomenclature used throughout this report (e.g., H1L, H3L, etc.) can be referenced using the single line diagram.

Figure 4-1: The Regional Transmission System Supplying Toronto

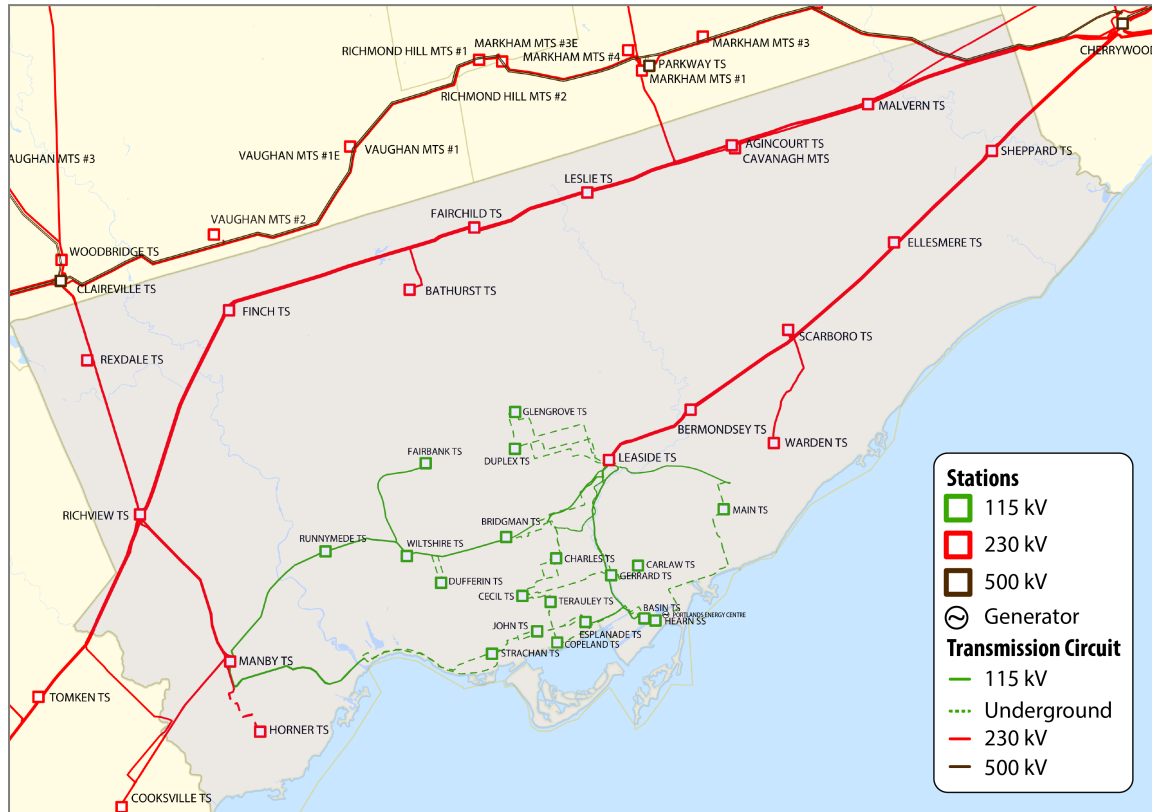
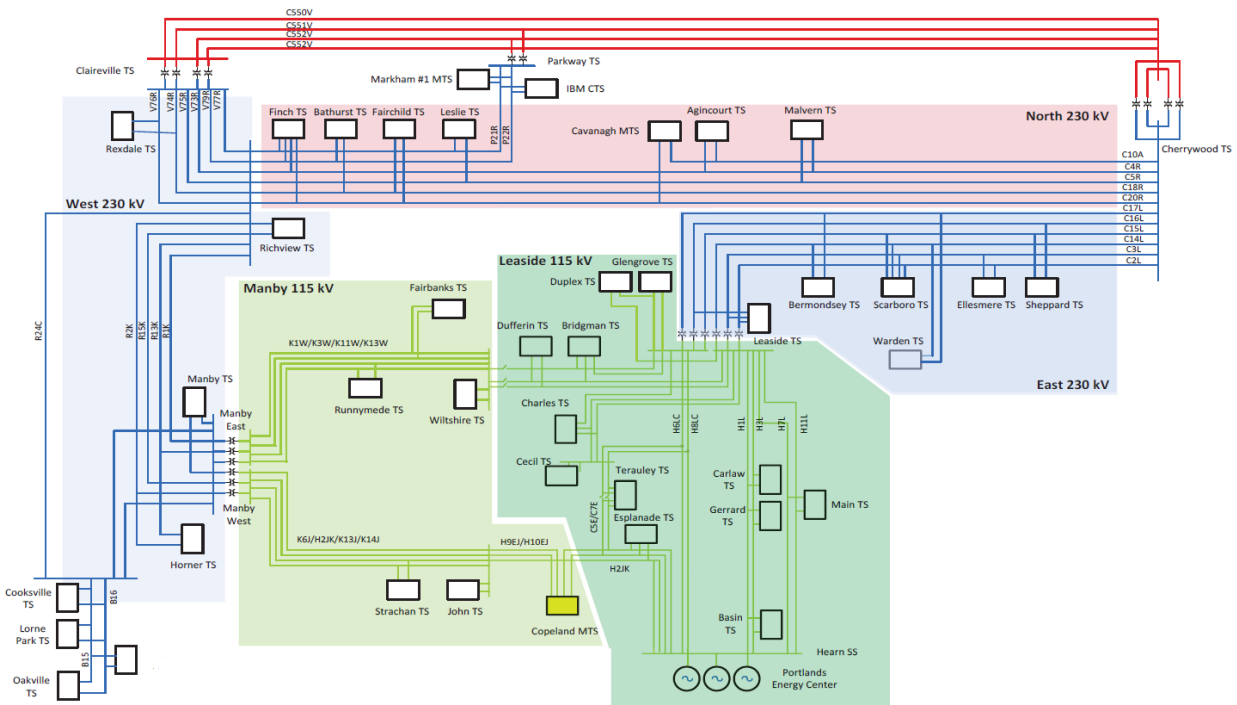

Figure 4-2: The Toronto Region Electrical System (Single-Line Diagram)



Completing the Toronto IRRP involved:

- Preparing a long term electricity peak demand outlook (forecast);
- Examining the load meeting capability and reliability of the transmission system supplying the region, taking into account facility ratings and performance of transmission elements, transformers, local generation, and other facilities (such as reactive power devices);
- Assessing system needs by applying a contingency-based assessment and reliability performance standards for transmission MTS supply in the IESO-controlled grid as described in Section 7 of ORTAC;
- Confirming identified end of life asset replacement needs and timing with Hydro One;
- Establishing alternatives to address system needs, including, where feasible and applicable, possible energy efficiency, generation, transmission and/or distribution, and other approaches such as NWAs;
- Engaging with the community on needs, findings, and possible alternatives;
- Evaluating alternatives to address near and long term needs; and
- Communicating findings, conclusions, and recommendations within a detailed plan.

5. Peak Demand Outlook

The electricity system needs that are in scope for regional planning are driven by the limits of the transmission infrastructure supplying an area, which is sized to meet peak demand requirements (rather than energy demand requirements).⁶ Peak demand requirements appearing at the station level are aggregated to understand the limits of the regional transmission system supplying the area as well as individual stations. Regional planning typically focuses on the regional-coincident peak demand to assess regional transmission needs, and individual station peaks to assess local transformer station capacity needs (the demand outlook is broken down spatially by transformer station, or each dual element spot network (DESN) that makes up a station⁷).

Individual stations within the Toronto study area typically experience peak loading at around the same time (e.g., weekdays, generally between 4 and 6 p.m. in summer, after consecutive hot days). There is also a high degree of coincidence between when individual stations peak and when the region peaks.

5.1 Demand Outlook Methodology

Toronto Hydro, in consultation with the Working Group, prepared a peak demand outlook at the transformer station bus level per IESO requirements for performing this study.

The outlook was developed in two parts:

1. Development of the Gross Peak Demand Outlook (Gross Outlook)
2. Development of the Net Peak Demand Outlook (Net Outlook)

The Gross Outlook recognizes the strengths of different forecasting methodologies for different time periods. The first 10 years is based upon the linear regression of past peak demands combined with known load additions and load redistributions. The period beyond 10 years is

⁶ Peak demand of the electric system is typically measured in terms of megawatts (MW) capacity; energy is the capacity needed over a period of time, for example, one megawatt used over one hour is a megawatt-hour (MWh).

⁷ A DESN refers to a standard station layout, where two supply transformers are configured in parallel to supply one or two medium-voltage switchgear (for example, 13.8 kV or 27.6 kV), which the distributor uses to supply load customers. This parallel dual supply ensures reliability can be maintained in the event of an outage or planned maintenance. A single local transformer station can have one, two, or more individual DESNs.

based upon the growth rates predicted from an econometric model that takes population, employment, and long term weather into account.

The Gross Outlook is a "business-as-usual" peak demand forecast under extreme weather. The Net Outlook considers load drivers that are over and above those considered in the "business as usual" Gross Outlook. These "new and emerging" load drivers were:

- electric vehicles
- electrification of mass transit
- fuel switching from natural gas to electric for space heating and water heating
- energy storage

The result was a station-by-station outlook of annual peak demand through to 2041. More details may be found in Appendix B: Peak Demand Outlook for Toronto 2017-2041.

5.2 The Outlook for Energy Efficiency

The outlook for future peak demand savings is based on mandated efficiencies from Ontario building codes and equipment standards, which set minimum energy efficiency levels through codes and regulations. To estimate the impact of efficiency codes and standards in the Toronto region, the peak demand savings for the residential, commercial and industrial sectors were estimated at the provincial level, compared with Toronto's station-based peak demand forecast, and expressed as a percentage of peak demand offset on an annual basis. This estimation took into account the breakdown of the peak demand at the station of residential, commercial, and industrial sector demand. Estimated peak demand savings, in MW, were calculated based on the percentage demand offset and the Demand Outlook described in Section 5.1.

These savings were subtracted from the demand outlook, and this forecast with efficiency codes and standards was used to test the sensitivity of the need dates as identified by the Net Outlook described in Section 5.1.

Table 5-1 shows the total peak demand savings attributable to efficiency codes and standards for the Toronto area, for selected years within the planning horizon.

Table 5-1: Estimated Peak Demand Savings from Codes and Standards

Year	2020	2025	2030	2040
Estimated savings (MW)	86	159	242	311

Source: IESO

A more detailed methodology on the outlook for energy efficiency, including assumptions and a breakdown by station and year, is provided in Appendix C: Energy Efficiency Forecast.

5.3 Outlook for Distributed Energy Resources

In addition to energy efficiency, DERs in the Toronto region have previously offset, and are expected to continue to offset peak demand. Previous procurements, including the Feed-in Tariff (FIT) Program, have helped to increase the amount of renewable DERs in Toronto. Other competitive generation procurements have also resulted in additional DER types, such as combined heat and power (CHP) projects.⁸ The DERs under contract with the IESO include a mix of solar photovoltaics (PV), CHP, and wind resources.

Further to these, competitive procurement pilots run by the IESO for energy storage resources have resulted in some energy storage projects in the region, and are supporting efforts to better understand the barriers related to integration of energy storage into Ontario's electricity market.

The peak demand impact of DERs that were connected to the system at the time the demand outlook was produced would be implicitly accounted for in the outlook. Given the difficulty of predicting where future DERs may be located, and uncertainty around future DER uptake, no further assumptions have been made regarding future DER growth. Instead of assuming future DER growth implicitly as a load modifier in the demand outlook, the potential of future DERs will be considered as potential solution options.

While the FIT Program and other competitive procurements for small-scale generation, including CHP, have ended, the IESO has been engaged in developing market-based mechanisms to enable a variety of electricity resources to compete in the electricity market. In addition, the IESO is engaged in several activities to enable DERs as alternatives to wires-based solutions. This includes working with other sector participants to identify and overcome

⁸ Since the IRRP forecast was developed, contracts for some generators included in the 2017 list have been terminated.

barriers to DER participation and implementation, as many of the issues extend beyond the IESO's mandate.

The IESO's work and other electricity sector initiatives related to DER barriers are expected to inform ongoing discussions on possible future DER options in Toronto, as per the recommendations made in this IRRP.

6. Power System Needs

Based on the demand outlook, system capability, identified end of life asset replacement needs, and application of provincial planning criteria, the Working Group identified electricity needs in the Toronto region in the near, medium, and long term.

6.1 Needs Assessment Methodology

ORTAC,⁹ the provincial criteria for assessing the reliability of the transmission system, was applied to assess supply capacity and reliability needs. ORTAC includes criteria related to the assessment of both the bulk transmission system and local or regional reliability requirements. See Appendix D: Toronto IRRP Study Results, and Appendix E: Station Capacity Assessment, for more details.

In applying ORTAC, three broad categories of needs can be identified:

- **Local Capacity** describes the electricity transmission system's ability to deliver power to LDCs through regional step-down transformer stations. This is determined by the Limited Time Rating (LTR) of the station, which is typically determined by the rating of its smallest transformer(s), under the assumption that the largest transformer is out of service.¹⁰
- **Regional Capacity** is the electricity transmission system's ability to provide continuous supply to LDCs in a local area, which is limited by the load meeting capability (LMC) of the transmission facilities in the area. The LMC is determined by evaluating the maximum peak demand that can be supplied to an area accounting for limitations of the transmission element(s) (e.g., a transmission line, group of lines or autotransformer), when subjected to contingencies and criteria prescribed by ORTAC. LMC studies are conducted using power system simulations analysis (see Appendix D, Toronto IRRP Study Results, for more details). Regional capacity needs are identified when the peak demand for the area exceeds the LMC of regional transmission facilities.
- **Load Security and Restoration** is the electricity transmission system's ability to minimize the impact of potential supply interruptions in the event of a credible contingency (e.g., a transmission outage considered for planning purposes), such as an outage on a double-circuit tower line resulting in the loss of both circuits. Load security

⁹ http://www.ieso.ca/imoweb/pubs/marketadmin/imo_req_0041_transmissionassessmentcriteria.pdf

¹⁰ A station's rating is determined by its most limiting component(s), which may not always be the transformer(s).

describes the maximum limit of load interruption that is permissible in the event of a transmission outage considered for planning. These limits reflect past planning practices in Ontario. Load restoration describes the electricity transmission system's ability to restore power to a transmission customer (e.g., LDC) affected by a transmission outage within specified time frames. Specific requirements can be found in ORTAC, Section 7, Load Security and Restoration Criteria.

The plan also identifies requirements related to the end of life of transmission assets. End-of-life asset replacement needs are identified by the transmitter based on a variety of factors, such as asset age, condition, expected service life, and risk associated with the failure of the asset. Replacement needs identified in the near and early medium term time frame typically reflect the assessed condition of the assets, while replacement needs identified in the longer term are often based on the equipment's expected service life. As such, any recommendations for medium term needs or those farther out reflect a potential for the need date to change based on priority and/or updates to asset condition.

6.2 Power System Needs

Through the planning studies for the Toronto IRRP, the Working Group identified four main categories of needs: (1) end of life asset replacement, (2) local transformer station capacity, (3) regional supply capacity, and (4) load security and restoration. In addition, pursuant to ORTAC provisions, maintaining a higher level of reliability performance (i.e., above the minimum standards) was also considered which identified some 'discretionary' reliability needs.¹¹ The specific needs under each of these categories are explained in the sections that follow.

6.2.1 End-of-life Asset Replacement Needs

Hydro One identified a number of end of life transmission asset replacement needs for the Toronto region in the needs assessment phase of this regional planning cycle, with several needs arising in the near to medium term.

¹¹ 'Discretionary' reliability needs are transmission system issues that are flagged through the application of a uniform set of planning criteria for all of Toronto's transmission system (e.g., by applying 'bulk power system' criteria to 'local area' facilities). This identifies issues that are discretionary in the sense that the reliability performance of the system complies with the criteria; but may represent opportunities to improve reliability to an area if cost-effective opportunities are available.

Since end of life needs are based on the best available asset condition information at a given point, the timing of asset replacement can change, as more recent asset condition results become available. If asset deterioration occurs faster than predicted, need dates may need to be advanced. As a result, the scope and timing of some of these needs have been updated since the needs and scoping assessments were completed.

6.2.1.1 Near-term Asset End-of-life Replacement Needs

Three near term asset end of life replacement needs were addressed within the scope of this plan (Table 6-1). These needs are described further in this Section. The options considered for addressing these needs are described in Section 7.1.1.

Table 6-1: Toronto Region End-of-life Asset Replacement Needs (Near term)

Facilities	Need	Expected Timing
Leaside Junction to Bloor Street 115 kV overhead transmission lines (H1L/H3L/H6LC/H8LC)	End of life of the approximate 2-km overhead line sections	2022-2023
Leaside TS to Balfour Junction 115 kV overhead transmission lines (L9C/L12C)	End of life of the approximate 3.6-km overhead line sections	2023-2024
Main TS	End of life of transformers T3 and T4, 115 kV line disconnect switches, and 115 kV current voltage transformers	2021-2022

Leaside to Bloor Street 115 kV overhead transmission lines (H1L/H3L/H6LC/H8LC)

The 115 kV overhead transmission lines H1L, H3L, H6LC, and H8LC provide supply to the eastern part of central Toronto from Leaside TS. The end of life part of the line is a 2-km section that runs from Leaside Junction to Bloor Street Junction in the Don Valley, and is on a common tower with four circuits (Figure 6-1). Hydro One has determined the conductors are reaching the end of their useful life, and will need to be replaced by 2022-2023 to maintain safety and reliability.

Figure 6-1: Leaside to Bloor Street Junction 115 kV Overhead Transmission Lines

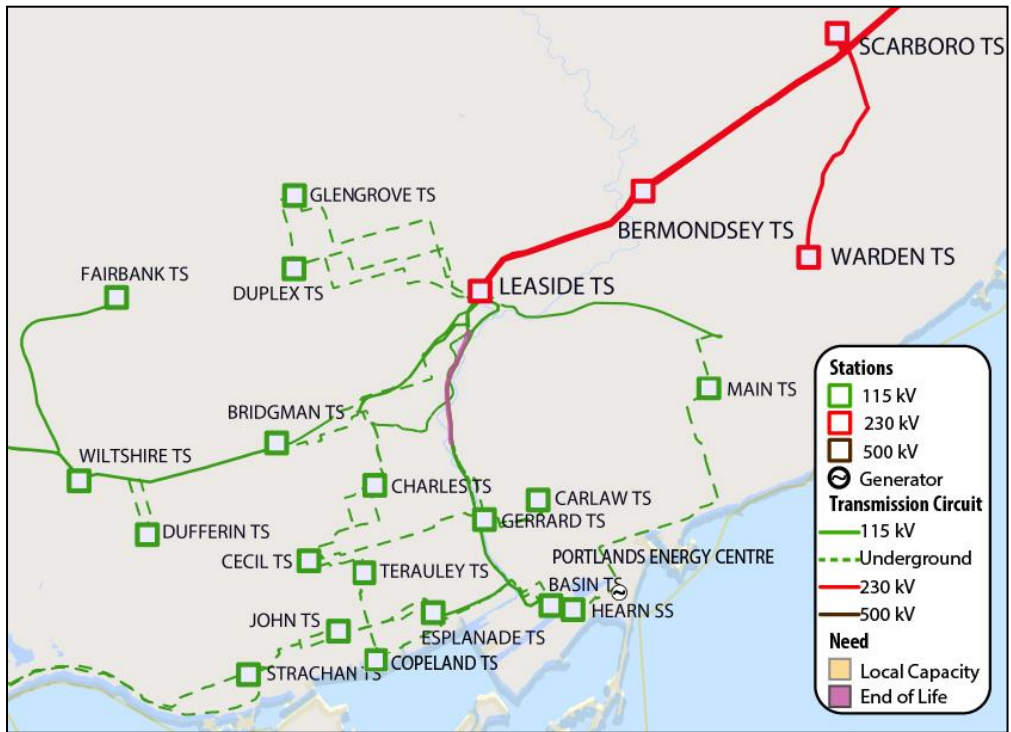

Leaside to Balfour 115kV overhead transmission lines (L9C/L12C)

The 115 kV overhead transmission lines L9C and L12C provide supply to central Toronto from Leaside TS (to Cecil TS). The section of the line that runs between Leaside TS and Balfour Junction is about 3.6 km in length, and runs through the Don Valley and along an existing rail corridor (Figure 6-2). This line is more than 80 years old and the conductors have been identified by Hydro One as reaching the end of their useful life, and requiring replacement by 2023-2024 to maintain safety and reliability.

Figure 6-2: Leaside to Balfour 115kV Overhead Transmission Lines

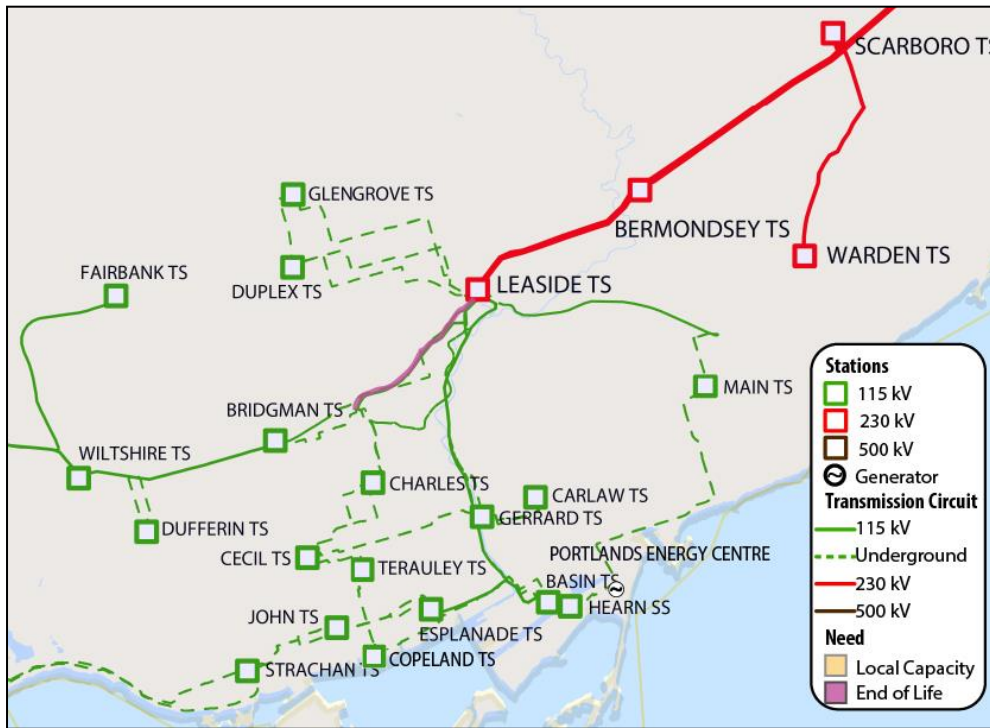

Main TS transformers and associated station equipment

Main TS is a local transformer station serving approximately 60 MW of load in east-central Toronto, including the Danforth and Beach neighbourhoods (Figure 6-3). The two transformers at the station, T3 and T4, are currently about 50 years old. Hydro One is currently working with Toronto Hydro to replace the end of life transformers, along with other equipment, such as 115 kV line disconnect switches, current transformers and voltage transformers.

Main TS is supplied by a combination of overhead and underground 115 kV circuits from Leaside TS to Hearn TS (H7L and H11L). Two sections of the original underground cable supply circuits are currently undergoing refurbishment due to their age (about 60 years old) and condition.

The station is currently more than 70 per cent utilized and resupplying the area load via adjacent station facilities is not possible. As with many established areas of the city, urban growth and development is likely in the Main TS area.

Figure 6-3: Location of Main TS

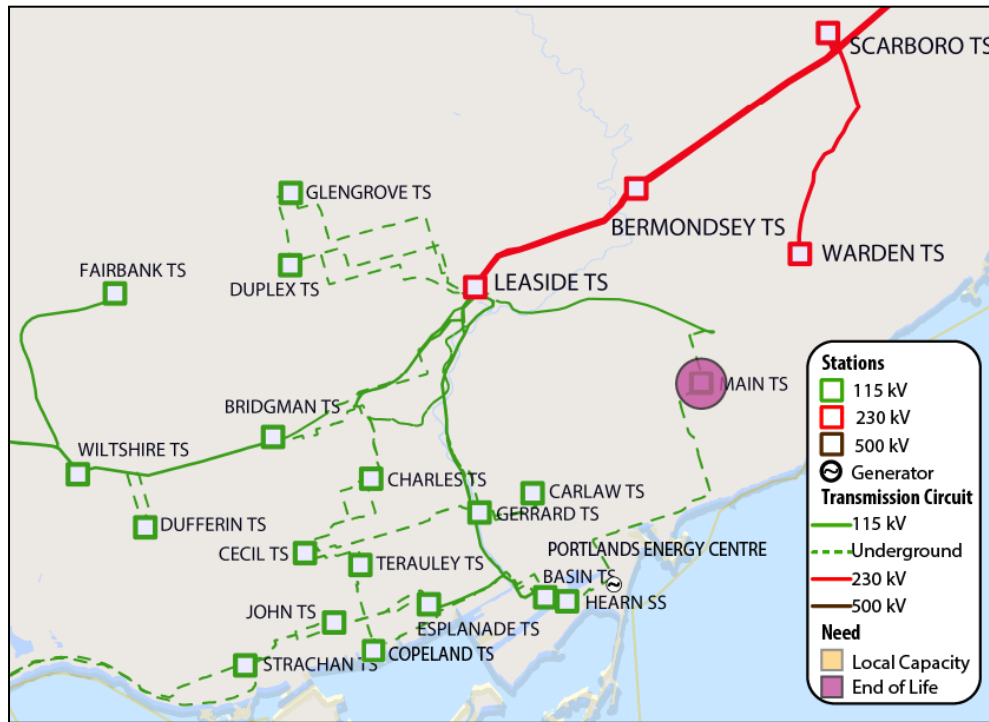

6.2.1.2 Medium-term Asset End-of-life Replacement Needs

Four asset end of life replacement needs occurring in the medium term were considered within the scope of this plan (Table 6-2). These needs are described further in this Section. The options considered for addressing these needs are described in Section 7.1.1.

Table 6-2: Toronto Region End-of-life Asset Replacement Needs (Medium term)

Facilities	Need	Expected Timing
Esplanade TS to Terauley TS 115 kV underground transmission cables (C5E and C7E)	End of life of underground cables from Esplanade TS to Terauley TS in downtown Toronto	2024-2025
Manby TS	End of life of major station equipment, including: autotransformers T7, T9, and T12, step-down transformer T13, and the 230 kV yard	2025-2026
John TS	End of life of transformers T1, T2, T3, T4, T6, and 115 kV breakers	2026-2027
Bermondsey TS	End of life of transformers T3 and T4	2025-2026

C5E/C7E 115 kV underground transmission cables

The 115 kV underground transmission cables C5E and C7E provide supply to Terauley TS in Toronto's downtown core. Installed more than 58 years ago, these paper-insulated, low-pressure oil filled cables extend about 3.6 km from Esplanade TS to Terauley TS, and are partially routed near Lake Ontario (Figure 6-4). They have been deemed by Hydro One to be at the end of their useful life, and requiring replacement as soon as possible, given that the risk of cable failure resulting in oil leaks and adverse environmental impacts is increasing with time.

Figure 6-4: C5E/C7E 115 kV Underground Transmission Cables

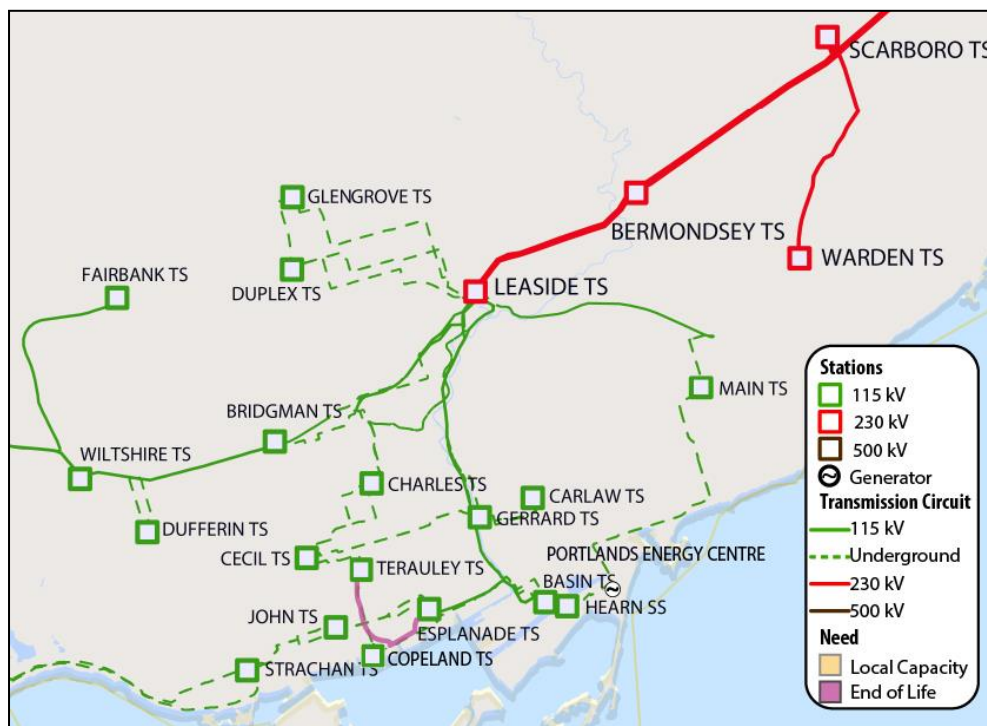

Manby TS

Manby TS is a major switching and autotransformer station supplying the western portion of the central Toronto 115 kV transmission system (Figure 6-5). Station facilities include six 230 kV/115 kV autotransformers (T1, T2, T7, T8, T9 and T12), a 230 kV switchyard, a 115 kV switchyard, and three DESNs with six 230/27.6 kV step-down transformers that supply customers in the immediate vicinity of the station. Three of the autotransformers (T7, T9 and T12) and one of the step-down transformers (T13) are close to 50 years old and, along with the 230 kV oil circuit breakers, have been identified to be at the end of their useful life. All of this end of life equipment is scheduled to be replaced in 2025-2026.

Addressing end of life needs at Manby TS represents a major undertaking that needs to be well coordinated in consideration of Toronto’s long term needs and future supply options.

Figure 6-5: Location of Manby TS

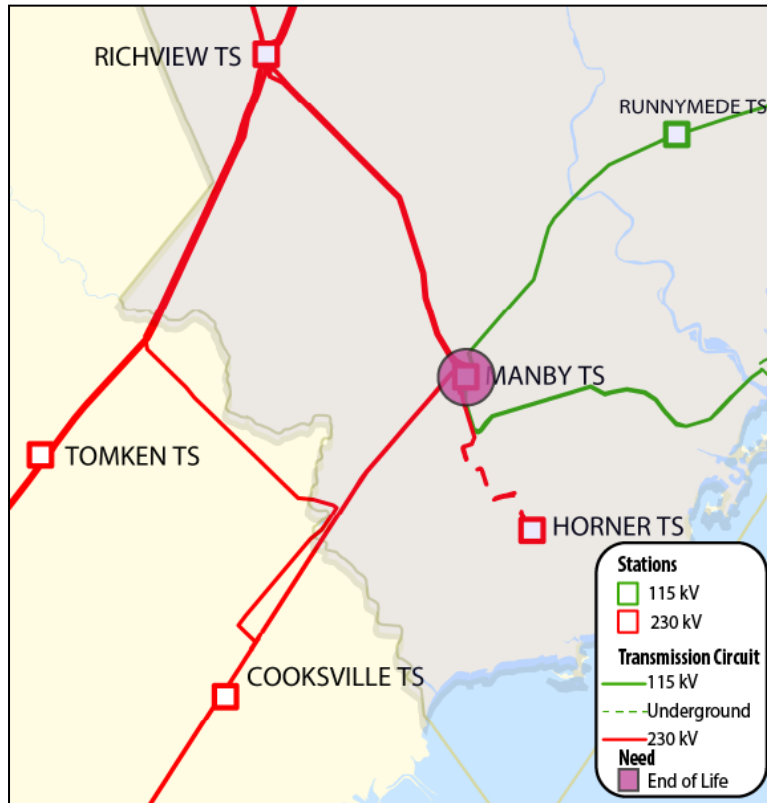

John TS

Built in the 1950s, John TS is connected to the 115 kV Manby West system and supplies much of Toronto’s downtown financial district (Figure 6-6). Station facilities include six 115/13.8 kV step-down transformers (T1, T2, T3, T4, T5 and T6) and a 115 kV switchyard. Toronto Hydro’s switchgear at the station has reached the end of its useful life, and is expected to be replaced starting in 2024-2025. In addition, Hydro One has identified the step-down transformers at John TS (T1, T2, T3, T6), as well as the 115 kV breakers to be at the end of their useful life and require replacement within the near to medium term. Because of their deteriorated condition, transformer T4 has already been replaced and T1 is scheduled to be replaced in Q4 2019. The approximate timing for the station refurbishment is 2026-2027.

Figure 6-6: Location of John TS

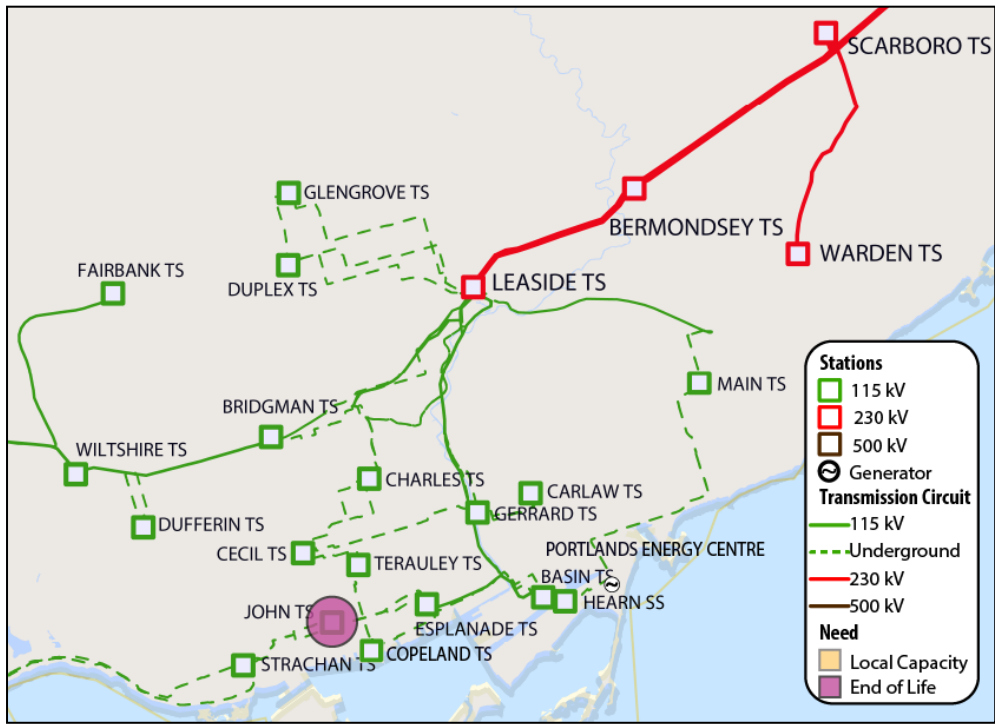

Bermondsey TS

Bermondsey TS supplies customers in the western part of Scarborough (Figure 6-7). The station is comprised of two DESNs, one of which (T3/T4 DESN 2) was built in 1965, and the other (T1/T2 DESN 1) in 1990. DESN 2 has been identified by Hydro One to be at its end of life and is expected to be replaced by 2025-2026. Bermondsey TS has a total of 18 distribution feeders supplying Toronto Hydro customers: the older T3/T4 DESN 2 has 12 feeders, while the newer T1/T2 DESN 1 has six feeders. The total loading on the station is forecast to remain below its capacity over the planning horizon. This provides an opportunity to review configuration and component sizes to best meet future needs.

Figure 6-7: Location of Bermondsey TS

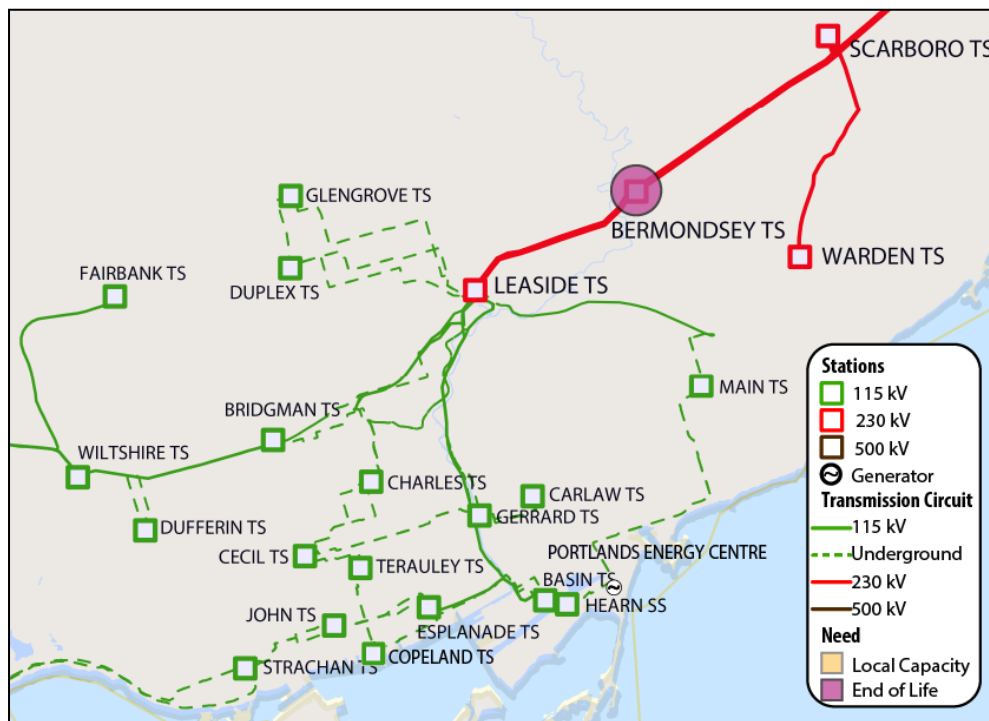

6.2.2 Supply Capacity Needs

Supply capacity needs at local step-down transformer stations were found at five transformer stations. A breakdown by year of the forecasted station loadings, as well as a more detailed description of the methodology for carrying out this assessment, is provided in Appendix E: Station Capacity Assessment.

6.2.2.1 Local Transformer Station Capacity Needs

Table 6-3: Toronto Region Transformer Station Capacity Needs

Station	Description	Timing ^{12,13}
Manby TS	A transformer capacity need was identified for the load supplied by all three DESNs ¹⁴	2023 for T5/T6 2032 for T3/T4 2034 for T13/T14
Strachan TS	A transformer capacity need was identified for the load supplied by both DESNs	2030 for T13/T15 2033 for T12/T14
Basin TS	A transformer capacity need was identified for the load supplied by the T3/T5 DESN (the only DESN at Basin)	2033
Leslie TS	A transformer capacity need was identified for the load supplied by the T3/T4 DESN	2033
Wiltshire TS	A transformer capacity need was identified for the load supplied by the T1/T6 DESN	2035

The locations of the local capacity needs are shown in Figure 6-8; four of the five local capacity needs are situated in the Central Toronto area.

¹² The timing presented in the table is consistent with the demand outlook provided by Toronto Hydro (net of new energy efficiency and distributed energy resources until the end of 2020); the timing of these capacity needs inclusive of future energy efficiency codes and standards is discussed in the subsections following the table.

¹³ Even though local transformer station capacity needs are presented in terms of the individual DESNs within the station, for the purpose of planning and implementing solutions, the needs at each station are generally addressed as one need requiring a holistic solution.

¹⁴ This need was identified and a solution was recommended in the 2015 Central Toronto IRRP. The status of the 2015 recommendation is discussed in Section 7.2.

Figure 6-8: Location of Local (Transformer Station) Capacity Needs

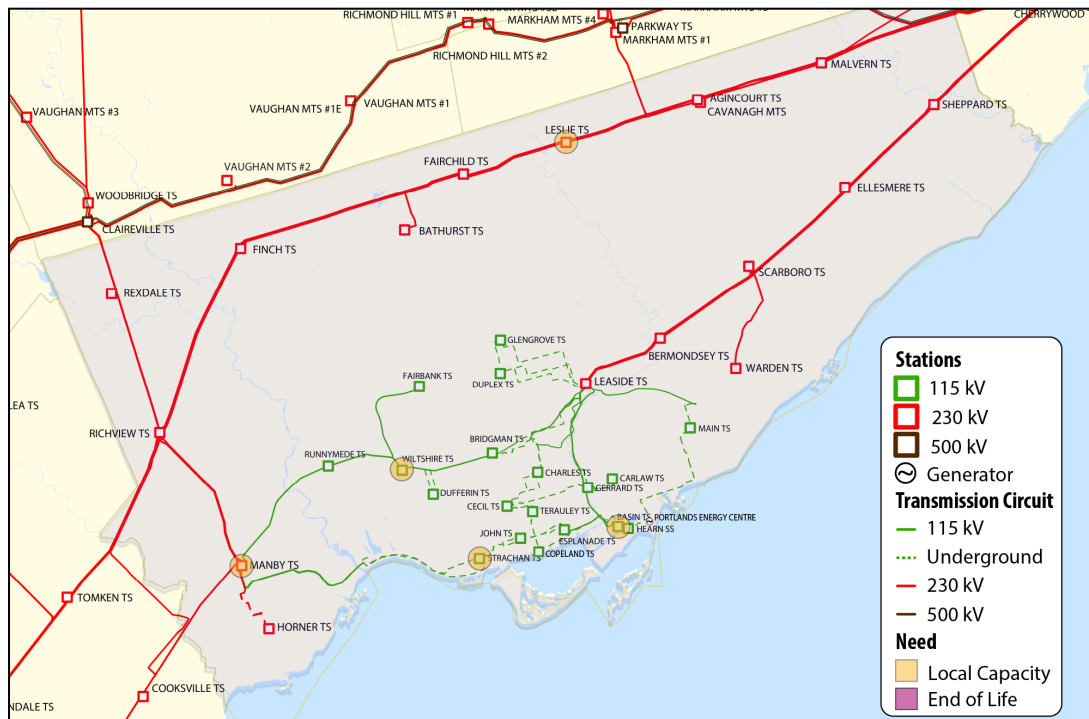

Manby TS (step-down transformation capacity)

Manby TS currently consists of three DESNs connected to the 230 kV system. This step-down transformer station, which supplies customers in the area surrounding Islington Town Centre from the Humber River west to the Toronto City limit, shares a yard with, but is separate from, the larger Manby 230/115 kV autotransformer station that provides 115 kV supply to the western portion of downtown Toronto. With a combined capacity of 240 MVA (216 MW), all three DESNs are forecast to exceed their capacity, starting in 2023 for the T5/T6 DESN 2, 2032 for the T3/T4 DESN 1, and 2034 for T13/T14 DESN 3.

The peak demand impacts of efficiency codes and standards were not taken into account for the timing of this need. Demand at Manby TS has already exceeded the station’s capacity in several recent years. This issue was discussed in the 2015 Central Toronto IRRP, solutions were evaluated, and the recommendations to address the need are currently being implemented by Hydro One and Toronto Hydro. These include building a second DESN at Horner TS in south Etobicoke, and transferring load from Manby TS to the new Horner DESN.

Strachan TS

Strachan TS consists of two DESNs connected to the 115 kV system supplied from Manby TS (West Yard). Strachan TS supplies load to the west of the downtown core at 13.8 kV distribution voltage. The two DESNs have a combined capacity of 188 MVA, or 169 MW (80 MVA for T12/T14 DESN 1, and 108 MVA for T13/T15 DESN 2).

The T13/T15 DESN 2 is forecast to reach its capacity as early as 2030, while the T12/T14 DESN 1 is forecast to reach its capacity as early as 2033. Assuming the future potential impact of efficiency codes and standards, the timing of this need is deferred to 2033 and 2038 for the T13/T15 DESN 1 and T12/T14 DESN 2, respectively.

Figure 6-9 shows the demand outlook for the two DESNs at Strachan TS, as compared to the individual capacity of each DESN.

Figure 6-9: Demand Outlook for Strachan TS DESNs Compared to Capacity

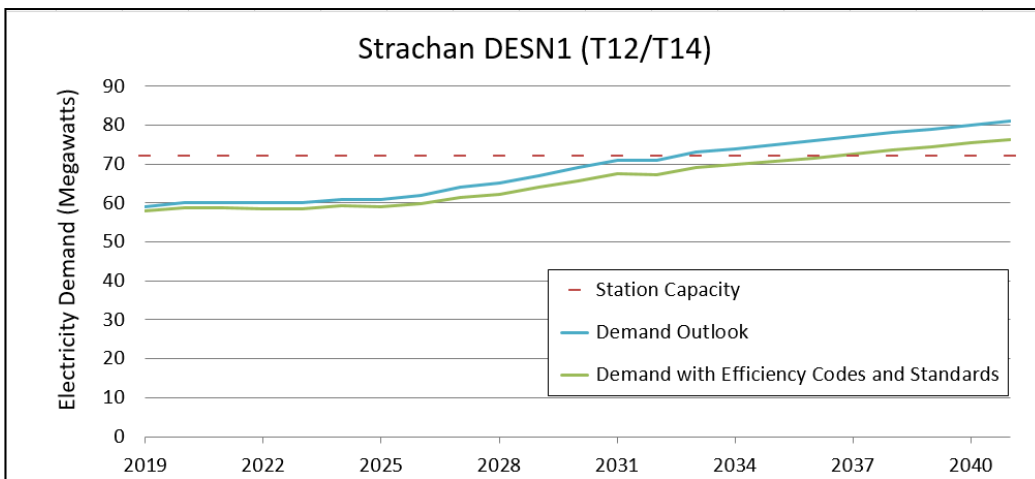

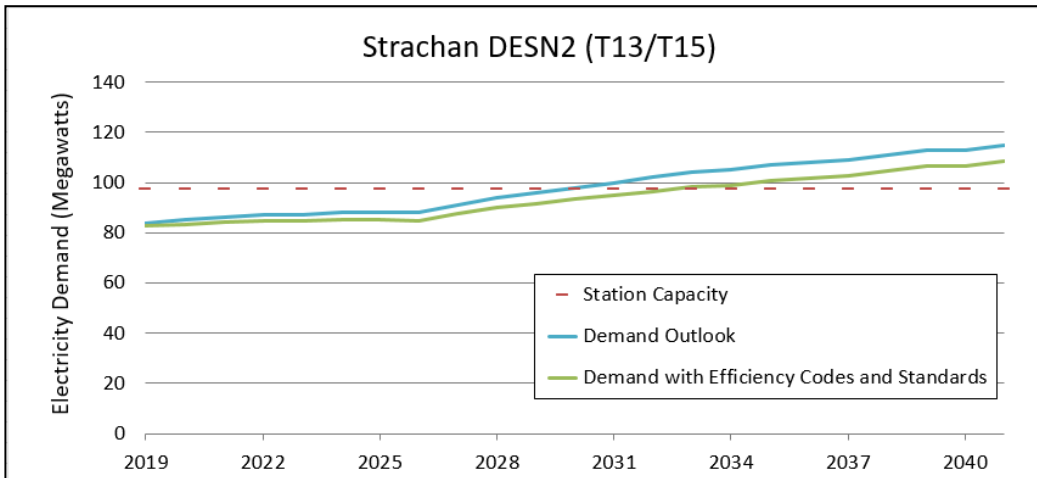

Basin TS

Basin TS has a single DESN (T1/T2) connected to the 115 kV system, supplying two low-voltage switchgear at a distribution voltage of 13.8 kV. The station has a total capacity of 98 MVA, or approximately 88 MW.

Basin TS is forecast to reach its capacity as early as 2033. Assuming the future potential impact of efficiency codes and standards (post-2020), the timing of this need is deferred to 2040.

Figure 6-10 shows the demand outlook for Basin TS, as compared to the station capacity.

Figure 6-10: Demand Outlook for Basin TS DESN Compared to Capacity

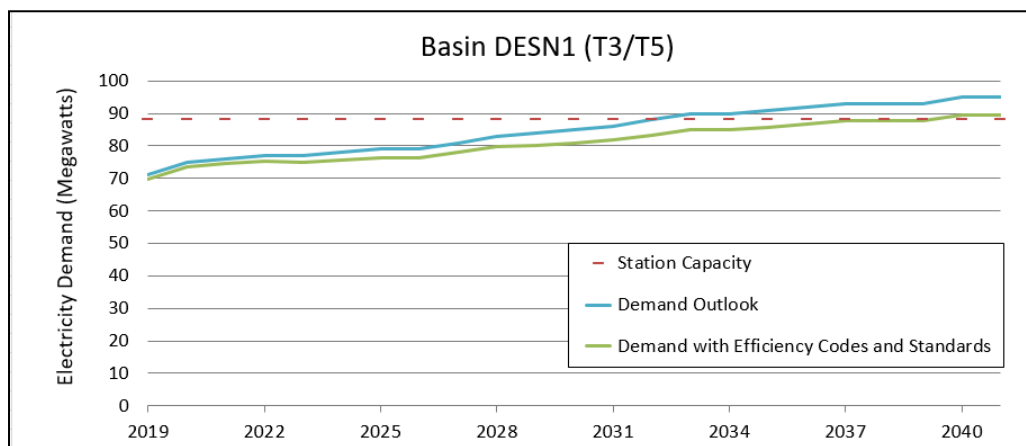

In addition to the forecast growth, the City of Toronto and Waterfront Toronto have been engaged in a master planning exercise for the Port Lands neighbourhood redevelopment and

re-naturalization of the mouth of the Don River. These plans involve a number of requests to examine relocation or redesign parts of the 115 kV transmission network in and around Basin TS, including the possible relocation of Basin TS itself.

Given the absence of concrete plans and timelines for urban development in the area, the timing of the capacity need at Basin TS is uncertain.

Leslie TS

Leslie TS has two DESNs connected to the 230 kV system. The T1/T2 DESN 1 supplies load at 27.6 kV and 13.8 kV, while the T3/4 DESN 2 supplies load at 27.6 kV. The total station capacity of Leslie TS is 325 MW. The T1/T2 DESN 1 has a capacity of 149 MVA (134 MW) and the T3/4 DESN 2 has a capacity of 194 MVA (175 MW). While the other three transformers are relatively new (installed between 1988 and 2012), transformer T1, which was installed in 1963, may require replacement within the planning horizon of this IRRP, even though it has yet to be identified as being at the end of its life.

The T3/4 DESN 2 is forecast to reach its capacity as early as 2033. Assuming the potential impact of future efficiency codes and standards, the timing of this need is deferred to 2039. Figure 6-11 shows the demand outlook for the two DESNs at Leslie TS, as compared to the individual capacity of each DESN.

Figure 6-11: Demand Outlook for Leslie TS Compared to Capacity

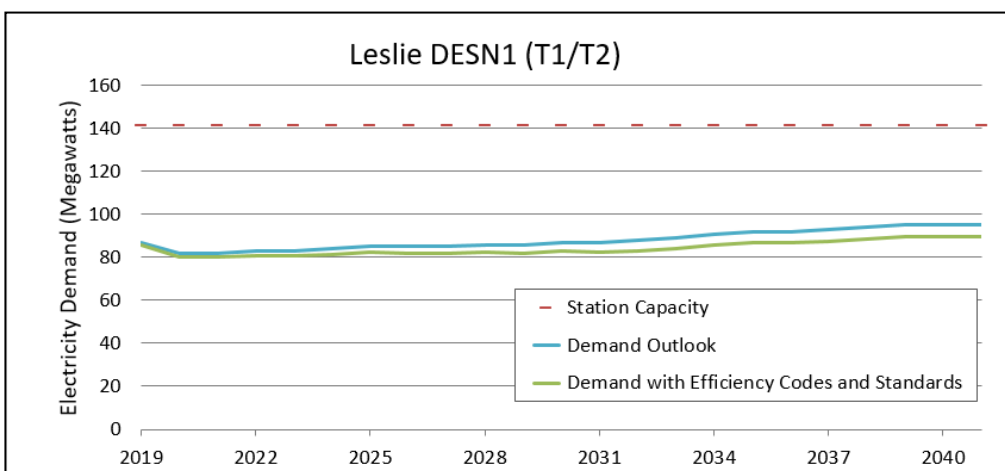

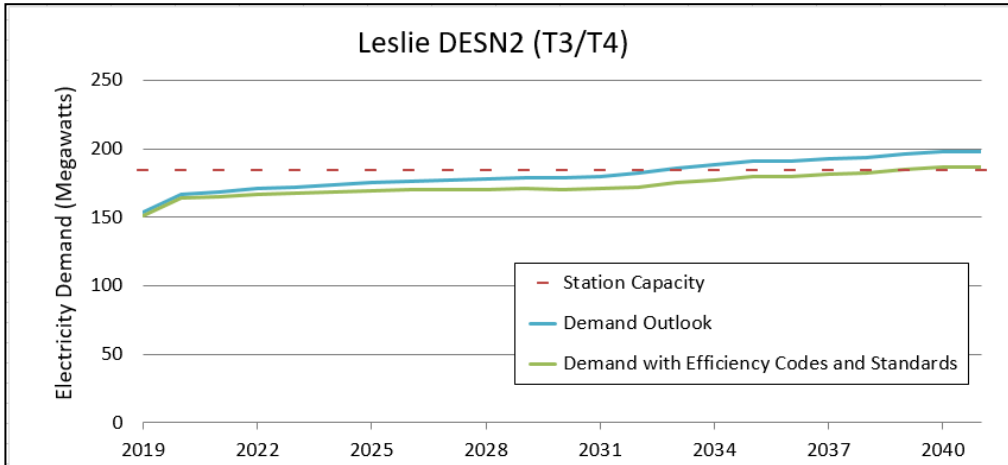

Wiltshire TS

Wiltshire TS has two DESNs connected to the 115 kV system supplied from the Manby TS (East Yard). Wiltshire TS supplies customer demand to the northwest of the downtown core, including the Junction neighbourhood, at 13.8 kV distribution voltage. The two DESNs have a combined capacity of 151 MVA, or 136 MW: 51 MVA for the T1/T6 DESN 1, and 100 MVA for the T2/T7 DESN 2. These two DESNs supply three Toronto Hydro 13.8 kV buses.

The outlook is forecasting load growth at Wiltshire TS, which can be attributed to growth and urban redevelopment in the area.

The T1/T6 DESN 1 is forecast to reach its capacity as early as 2035. Assuming the future potential impact of efficiency codes and standards, the timing of this need is beyond the study period.

Figure 6-12 shows the demand outlook for the two DESNs at Wiltshire TS, as compared to the capacity of each DESN.

Figure 6-12: Demand Outlook for Wiltshire TS DESN Compared to Capacity

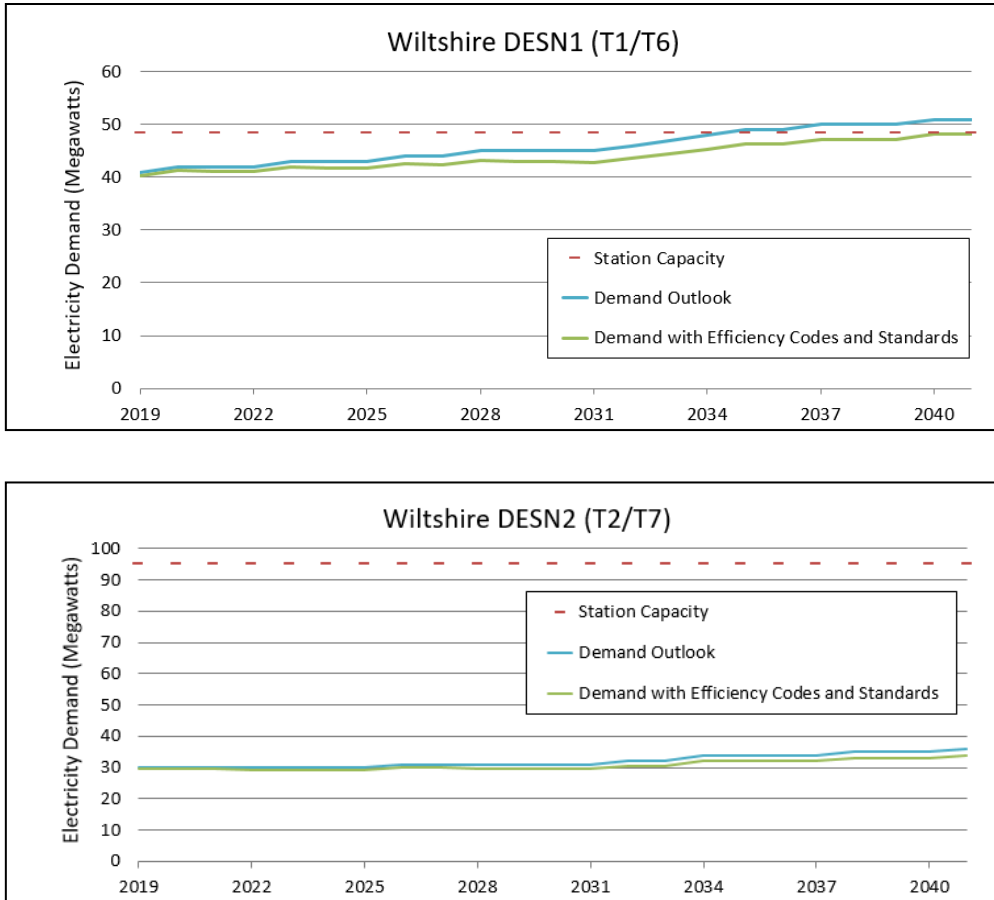

6.2.2.2 Regional Supply Capacity Needs

Regional capacity needs are related to the 230 kV or 115 kV transmission system that delivers electricity from the interconnected grid into Toronto. The planning studies re-tested the need for the Richview TS to Manby TS 230 kV corridor upgrades that were recommended in the previous planning cycle. The results of this assessment reaffirm this need and are reported in this section. In the longer term, regional supply capacity needs emerge at Leaside TS, Manby TS, and on some 115 kV circuits within the Manby and Leaside Sectors.

Richview TS to Manby TS 230 kV corridor

The previous cycle of regional planning recommended that the 230 kV bulk supply to Manby TS from Richview TS be reinforced to accommodate demand growth in Toronto, primarily driven in the near term by mass transit projects. The planning studies undertaken for this IRRP re-tested the need for this additional LMC upstream of Manby TS, accounting for changes in assumptions related to the revised demand outlook provided by Toronto Hydro for the purpose of undertaking this IRRP, and the peak demand outlook for Cooksville west stations from the 2015 GTA West Needs Assessment.

The assessment confirmed that, under normal system configuration, the most limiting contingency is the loss, in 2021, of circuit R15K, which would cause R2K (also running from Richview TS to Manby TS) to exceed its capacity rating. This limitation exists regardless of whether the Metrolinx traction power substation (TPSS) is in-service; however, the additional capacity will support further mass transit electrification.

Without reinforcement to the Richview TS to Manby TS 230 kV circuits, the ability to transfer Dufferin TS to Manby East supply can become limited during summer peak conditions, following the same R15K single contingency. As discussed below (under Leaside TS and Manby TS autotransformers), transferring Dufferin TS to Manby TS supply is a possible control action in a PEC out-of-service scenario (as well as other issues that could impact supply in the Leaside TS sector). Since having this control action available helps ensure a reliable and resilient transmission supply to Toronto, the Working Group continues to recommend reinforcement of the Richview TS to Manby TS 230 kV circuits with a target in-service date as soon as possible.

The detailed assessment of the Richview TS to Manby TS corridor need is provided in Appendix F: Richview TS to Manby TS Corridor Study.

Supply to downtown Toronto from Manby West (Manby to Riverside Junction)

The Manby West supply sector comprises four 115 kV supply circuits (H2JK, K6J, K13J, and K14J), which run from Manby TS to Riverside Junction on overhead lines, with two (and in some spans, up to four) circuits on a common structure. From Riverside Junction, these circuits

run underground to supply the downtown core.¹⁵ The Manby West supply sector is considered “non-bulk” and is designed to continuously supply demand up to the loss of a single circuit.

The planning studies are showing that all four Manby TS to Riverside Junction circuits violate the reliability criteria between 2030 and 2040. Under the most severe single element loss, the remaining circuits can be as much as 120 per cent overloaded by 2040. This is a reliability concern that will need to be addressed in the long term.

Leaside TS and Manby TS autotransformers

The assessment of the Leaside autotransformer capacity is related to the presence and capacity of the 550 MW PEC facility, as both PEC and Leaside TS supply the Leaside sector. With an outage to the PEC steam turbine generator, the output of the plant would be reduced to 160 MW. Under this scenario, the Leaside autotransformers will begin to exceed their capacity limits by the 2030 to 2040 time frame, following outages on the 230 kV transmission lines that supply Leaside TS from Cherrywood TS upstream. With a full PEC outage, two of the six autotransformers at Leaside TS (T15 and T16) would be overloaded under peak demand conditions.¹⁶

During short-term outages of elements of PEC, system control actions to reduce the Leaside sector load through the transfer of Dufferin TS to the Manby sector will alleviate pressure on the Leaside autotransformers. While this is an acceptable short-term measure, it is not considered a permanent solution because it exposes the Manby sector, and Dufferin TS customers in particular, to supply security risks related to transmission outages in the Manby sector.

Manby TS autotransformer capacity needs were identified as emerging by the 2030 to 2040 time frame. This capacity constraint is related to the rating of the smallest autotransformer at Manby TS (T12) following the loss of a companion transformer. There may be value in factoring these findings into the end of life replacement of the Manby TS autotransformers in 2025-2026, if there is a cost-effective and technically feasible means of addressing this capacity constraint within the scope of the replacement.

¹⁵ The underground section from Riverside Junction to Strachan Avenue have been recently refurbished due to its age and condition.

¹⁶ The 2030 forecast year was used to assess the full PEC outage scenario; it is likely that if such a scenario were experienced today at the time of system peak, then the Leaside TS autotransformers could experience an overload.

Bayview Junction to Balfour circuit (L15W) thermal capacity

The planning assessment shows that following the loss of circuit L14W, the companion circuit L15 (from Bayview Junction to Balfour Junction in the Leaside sector¹⁷) is forecast to marginally exceed its Long term emergency rating (LTE) in 2040. This need is deferred beyond the planning horizon once the forecast efficiency codes and standards savings are taken into account.

6.2.3 Load Security Needs

The transmission system must exhibit acceptable performance while following specified design criteria contingencies. The load security criteria can be found in Section 7.1 of ORTAC, and a summary of the load security criteria can be found in Table 6-4. All transformer stations in the Toronto region have at least a dual transmission supply, which allows the load served at the station to remain uninterrupted in the event of a single element contingency. Supply interruptions may occur after multiple element contingencies, but under all possible interruption scenarios, the amount of load interrupted remains within the limits prescribed in ORTAC.

Table 6-4: Load Security Criteria

Number of transmission elements out of service	Local generation outage?	Amount of load allowed to be interrupted by configuration	Amount of load allowed to be interrupted by load rejection or curtailment	Total amount of load allowed to be interrupted by configuration, load rejection, and/or curtailment
One	No	≤ 150 MW	None	≤ 150 MW
	Yes	≤ 150 MW	≤ 150 MW	≤ 150 MW
Two	No	≤ 600 MW	≤ 150 MW	≤ 600 MW
	Yes	≤ 600 MW	≤ 600 MW	≤ 600 MW

6.2.4 Load Restoration Needs

Described in Section 7.2 of ORTAC, load restoration criteria specify that the transmission system must be planned such that following design criteria contingencies, all interrupted load must be restored within approximately eight hours. When the load interrupted is greater than

¹⁷ These circuits are part of the path supplying Wiltshire TS from Leaside TS.

150 MW, the amount of load in excess of 150 MW must be restored within approximately four hours. When the load interrupted is greater than 250 MW, the amount of load in excess of 250 MW must be restored within 30 minutes. A visual representation of the load restoration criteria is shown in Figure 6-13.

Figure 6-13: Load Restoration Criteria

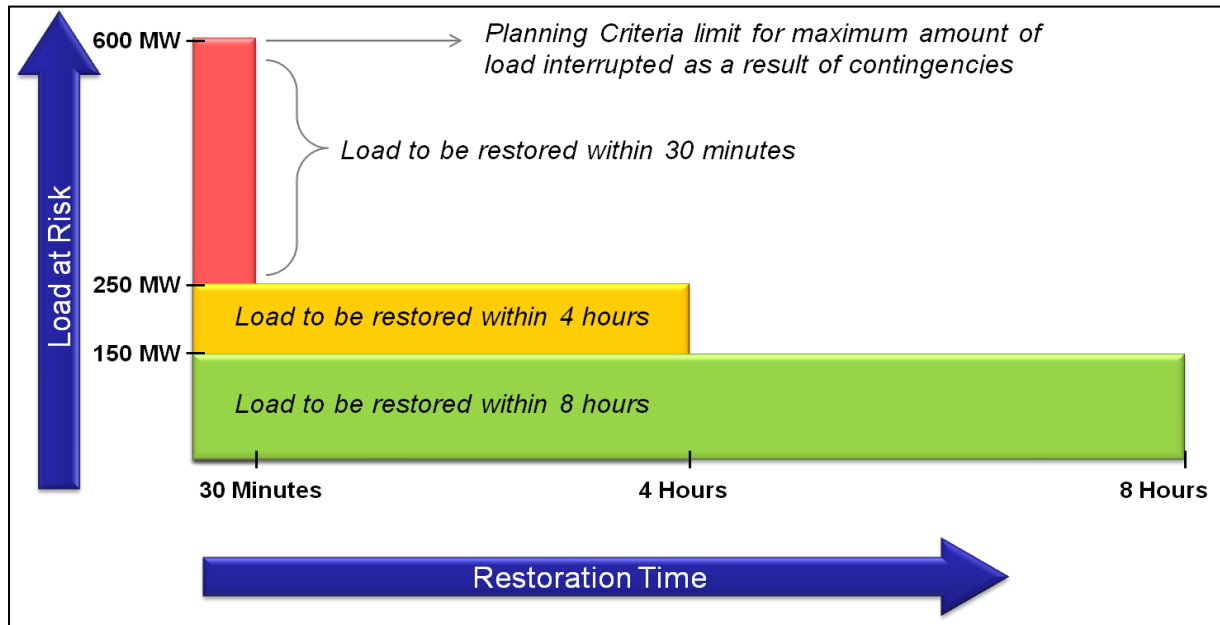

No load restoration needs were identified in the Toronto region following the design criteria contingencies that were tested. Under a situation where load loss has occurred and the transmission system has been reconfigured to restore power, but some customers are still experiencing an outage, additional measures may be taken in the operational time frame. These measures may include dispatching crews to repair the transmission system, reconfiguring the transmission or distribution system to transfer load to another delivery point, and use of temporary facilities, etc. Although electricity interruptions can not be eliminated, where possible, the system operator, transmitter, and distributor will undertake measures in real time to respond to outages and restore load as quickly as possible.

6.2.5 Discretionary Reliability Needs

Reliability performance is, in part, a function of the criteria that the transmission system needs to meet. In other words, the planning criteria stipulate the functional requirements of the transmission system to ensure reliability performance. Within Toronto, specific criteria apply to different parts of the transmission system because of the function and resulting consequences of

the loss of those different parts. In other words, less stringent criteria generally apply to transmission facilities where the impact is only local. Conversely, more stringent criteria apply when the consequences of a loss have a wider impact on the interconnected grid. The stringency of the planning criteria is commensurate with the severity of the consequence of contingencies that can impact the interconnected grid.

While, for study purposes, this plan applied the more stringent criteria to all parts of Toronto's transmission system (e.g., by assessing 'local area' facilities against 'bulk power system' criteria), not all areas are required to meet the more stringent criteria. ORTAC (Section 7.4) permits higher levels of reliability to be adopted for specified reasons. The results of the assessment in this study highlighted some 'discretionary reliability needs' for the purpose of generating insights as to where there may be opportunities to improve performance, but for which actions to resolve them are not required by the performance criteria that govern the planning and design of the electric power system. The discretionary reliability needs are documented in Appendix D: Toronto IRRP Study Results.

6.2.6 System Resilience for Extreme Events

One of the key measures of a resilient transmission system is its ability to withstand interruption, or restore supply during or after extreme events that impact many parts of the system. This section summarizes the capability, following analysis, of Toronto's regional transmission system to maintain supply and manage the risk posed by low-probability, high-impact events.

In 2013, the IESO conducted an assessment of the amount of load that could be restored following specific extreme contingencies involving the system that supplies downtown Toronto. The results of this assessment have not been made public due to security concerns related to the disclosure of critical energy infrastructure information and possible system vulnerabilities.

For this IRRP, key scenarios from the 2013 study were re-examined for the years 2020 and 2025. These include the loss of:

- Manby TS 115 kV switchyard
- Leaside TS 115 kV switchyard
- Four circuit tower structures emanating from the Manby TS and Leaside TS 115 kV switchyards

The results of the updated analysis found that the impact of the extreme contingencies on the 115 kV transmission system was limited to load interruptions within the Toronto region.

6.3 Summary of Needs Identified

Table 6-5 summarizes the electric power system needs identified in this IRRP. Note that discretionary needs identified in Section 6.2.5 are not included because these issues are flagged as potential opportunities to enhance reliability to Toronto but they do not require actions to address them at the present time.

Table 6-5: Summary of Needs Identified

Facilities	Need	Expected Timing
End-of-Life Assets		
Leaside Junction to Bloor Street 115 kV overhead transmission lines (H1L/H3L/H6LC/H8LC)	End of life of the approximate 2 km overhead line sections	2022-2023
Leaside TS to Balfour Junction 115 kV overhead transmission lines (L9C/L12C)	End of life of the approximate 3.6 km overhead line sections	2023-2024
Main TS	End of life of transformers T3 and T4, 115 kV line disconnect switches, and 115 kV current voltage transformers	2021-2022
Esplanade TS to Terauley TS 115 kV underground transmission cables (C5E and C7E)	End of life of underground cables from Esplanade TS to Terauley TS in downtown Toronto	2024-2025
Manby TS	End of life of major station equipment, including: autotransformers T7, T9 and T12, step-down transformer T13, and the 230 kV yard	2025-2026
John TS	End of life of transformers and 115 kV breakers	2026-2027
Bermondsey TS	End of life of transformers T3 and T4	2025-2026
Local Transformer Station Capacity		
Manby TS (DESN)	A transformer capacity need was identified for the load supplied by all three DESNs	2023
Strachan TS	A transformer capacity need was identified for the load supplied by both DESNs	2030

Facilities	Need	Expected Timing
Basin TS	A transformer capacity need was identified for the load supplied by the T3/T5 DESN (the only DESN at Basin)	2033
Leslie TS	A transformer capacity need was identified for the load supplied by the T3/T4 DESN	2033
Wiltshire TS	A transformer capacity need was identified for the load supplied by the T1/T6 DESN	2035
Regional Capacity		
Richview TS to Manby TS 230 kV Corridor	Load meeting capability upstream of Manby TS	2021
Supply to downtown Toronto from Manby West (Manby to Riverside Junction)	Load meeting capability of the 115 kV lines supplying downtown Toronto	2030-2040
Leaside TS and Manby TS	A capacity need was identified for Leaside TS and Manby TS 230/115 kV autotransformers	2030-2040
Bayview Junction to Balfour Junction Circuits	Overloading of L15 circuit for the loss of its companion circuit, L14W	2040

7. Plan Options and Recommendations

This section outlines the options considered to address transmission needs in the Toronto region, as well as the recommended plan with respect to each of these needs.

In considering options and developing recommendations, the Working Group has been mindful of the interest and preference, communicated through engagement with stakeholders, such as the City of Toronto, a local advisory committee that was in place from 2016 to 2018, and the general public, to explore NWA, such as DERs, for dealing with electricity system needs.

Given the interest in NWA as possible solutions for addressing Toronto's regional transmission needs, additional context on the changing landscape with respect to these resources, and on the approach to considering them, is provided below.

DERs as options to address needs in Toronto

The uptake in DERs across the province over the last decade is having an impact on the electricity system, both in terms of system demand and operability. While centralized procurement programs that supported the development of most DERs¹⁸ are no longer in place, DER deployment is expected to continue in Toronto. Toronto Hydro has filed investment plans for approval with the OEB to increase its ability to connect DERs to its system, and the IESO has expressed support for these plans.¹⁹

Much of the IESO's recent work with respect to DERs has focused on identifying the barriers to their development as alternatives to wires-based solutions, and options for reducing or overcoming those barriers. Specifically, the barriers to implementation of cost-effective NWA, including DERs, in regional planning are being investigated as part of the IESO's regional planning review initiative.²⁰ Further, a number of DER-focused initiatives are being undertaken as part of the work plan associated with the IESO's *Innovation Roadmap*.²¹ These initiatives

¹⁸ Since 2006, nearly 2,000 distributed energy resources (DERs), including solar PV, CHP, energy storage and wind, have connected to Toronto's distribution system.

¹⁹ See Toronto Hydro's rate application EB-2018-0165, Exhibit 2B, Section E7.2; and Exhibit 2B, Section B, Appendix F for IESO's Comment Letter.

²⁰ Launched in 2018, the [regional planning review process](#) is exploring a number of enhancements to regional planning, including potential barriers to non-wires solutions, opportunities for coordination between bulk system planning, community energy planning and market renewal, and a long term approach to replacing end-of-life transmission assets.

²¹ <http://www.ieso.ca/en/Get-Involved/Innovation/Innovation-Roadmap>

include research and white papers, demonstration and evaluation projects, and capital projects and process improvements. For a full list and descriptions, visit the [innovation projects page](#) on ieso.ca.

The Working Group believes that DERs need to continue to be studied to build the necessary tools and experience required to consider and evaluate them as potential solutions to regional electricity needs. This work is being undertaken through the above mentioned work plan. In the meantime, continued dialogue with the community is expected to play an important role in defining the potential for cost-effective NWA solutions. Further details are provided in the plan recommendations.

7.1 Evaluating Plan Options for Addressing Needs Identified in Toronto

The following sections describe the options considered to address the needs identified in Section 6.2.

The evaluation of possible plan options takes into consideration a number of factors, including technical feasibility, timing, cost, and alignment with local priorities. In light of the importance of cost as a planning consideration, solutions that are cost-effective and that maximize the use of existing infrastructure and assets are typically given priority for inclusion in the evaluation.

To help ensure that solutions will be available in time to address pressing needs, the IRRP identifies specific actions to be undertaken and/or implemented in the near and medium term. Given forecast uncertainty and the potential for technological and policy changes, investment in longer-term needs is not prudent at this point in time. Instead, the long term plan focuses on developing and maintaining the viability of long term options, engaging with communities, and gathering information to lay the groundwork for making decisions on future options.

As discussed in Section 6, solutions are needed to address (1) end of life asset replacements; (2) local transformer station capacity, and (3) regional supply capacity needs. In addition, the plan identifies some discretionary needs related to maintaining a higher level of reliability performance than those prescribed in ORTAC. This recognizes Toronto's position as the largest urban centre in Canada, and the ORTAC provision allowing the transmission customer and transmitter to agree on higher (or lower) levels of reliability. Firm recommendations to address discretionary needs are dependent on the availability of cost-effective solutions and the risk of the need materializing.

In developing the plan, the Working Group examined a range of solutions to address the near term needs, as well as activities to begin to lay a foundation for addressing needs in the longer term. These options are discussed and evaluated in the following sections.

7.1.1 Options for Addressing End of Life Asset Replacement

When transmission equipment reaches end of life, a number of alternatives can be considered. Transmission or distribution facilities may have changed since the equipment was built, community needs may have evolved, equipment standards may have changed, and/or opportunities for other options, such as energy efficiency, may be able to play a role.

Options to address end of life asset replacement needs in the Toronto region included:

- Retiring the asset or facilities
- Replacing the assets to the “right size” (e.g., larger or smaller) based on considerations, including future electricity demand, or changes to the use of the asset to realize reliability, resilience, or other benefits that an alternate configuration may provide
- Replacing the assets “like for like” or with the closest current equivalent
- Implementing NWAs

Based on the assessments conducted in this IRRP, each of the assets reaching its end of life in this plan was deemed critical for maintaining a sufficient and reliable supply of electricity to customers. As such, and given the magnitude and persistence of the needs, complete retirement and replacement with NWAs was screened out as an alternative in favour of replacing the assets with the closest available equivalent.

Leaside Junction to Bloor Street Junction 115 kV overhead transmission lines (H1L/H3L/H6LC/H8LC)

Three options were assessed to inform the preferred approach for addressing this end of life overhead line section:

1. **Replace the existing lines with 230 kV capable lines to increase future capacity (but continue to operate at 115 kV, for now):** This approach was ruled out because assessment indicated that none of these circuits would be thermally limited within the planning horizon. Also, because there is no plan to increase the transmission supply voltage (e.g., to 230 kV) to any of the stations supplied by the HxL or HxLC circuits, there would be no benefit for investing in replacement circuits at a higher operating voltage (or any associated tower investments) within the planning horizon.

2. **Replace the existing lines with 115 kV lines (like for like, built to current standards):** The planning assessments show that the LMC of the 115 kV transmission lines is adequate to supply the needs of Toronto within the planning horizon. New 115 kV transmission lines along this path built to today’s standards are expected to be able to carry more load, and operate in a more reliable manner, as compared to the existing equipment.

3. **Replace end of life assets with NWAs:** As NWAs, such as energy efficiency or DERs, would be very expensive compared to replacing end of life assets, the Working Group determined that they do not present a viable approach.

Table 7-1 summarizes the considerations related to the options. Based on the evaluation of the alternatives, this IRRP recommends that Hydro One proceed with like for like replacement of the end of life line sections.

Table 7-1: Options for Addressing Leaside Junction to Bloor Street Junction 115 kV Lines

	Replace with 230 kV capable	Replace like for like
Summary of Option	<ul style="list-style-type: none"> • Rebuild the existing line section to meet 230 kV standard 	<ul style="list-style-type: none"> • Refurbish the existing line section with the equivalent voltage standard
Potential Benefits	<ul style="list-style-type: none"> • Maintain capacity (if energized at 115 kV) or increase capacity (if energized at 230 kV) • Maintains reliability • Contributes to introducing 230 kV supply to downtown 	<ul style="list-style-type: none"> • Maintain or improve capacity and reliability • Better in-service date certainty
Potential Risks/ Issues	<ul style="list-style-type: none"> • If never energized at 230 kV, incremental costs for 230 kV capability will not provide value 	<ul style="list-style-type: none"> • None if the work is scheduled and completed outside of the peak demand season

Leaside TS to Balfour Junction 115 kV overhead transmission lines (L9C/L12C)

These two lines are critical for supplying Toronto’s electricity needs. Three options were assessed to inform a recommendation on the preferred approach to address this end of life overhead line section:

1. **Replace the existing lines with 230 kV capable lines (but continue to operate at 115 kV for now):** This approach was ruled out because assessment results indicated that none of these would be thermally limited within the planning horizon. Since there is not a plan to increase the transmission supply voltage to any of the stations supplied by these lines, it would not be beneficial to invest in replacement circuits at a higher operating voltage (or any associated tower investments).
2. **Replace the existing lines with 115 kV lines (like for like, built to current standards):** The planning assessments show that the LMC of the 115 kV transmission lines is adequate to supply the needs of Toronto within the planning horizon.
3. **Replace end of life assets with NWAs:** Given that energy efficiency, DERs and other NWAs would be very expensive compared to replacing end of life assets, the Working Group determined that NWAs do not present a viable approach.

Table 7-2 summarizes the considerations related to the options. Based on the evaluation of the alternatives, this IRRP recommends that Hydro One proceed with like for like replacement of the end of life line sections.

Table 7-2: Options for Addressing Leaside TS to Balfour Junction Transmission

	Replace with 230 kV	Replace like for like
Summary of Option	<ul style="list-style-type: none"> • Rebuild the existing line section to meet 230 kV standard 	<ul style="list-style-type: none"> • Refurbish the existing line section with the equivalent voltage standard
Potential Benefits	<ul style="list-style-type: none"> • Maintain capacity (if energized at 115 kV) or increase capacity (if energized at 230 kV) • Maintain reliability • Contributes to introducing 230 kV supply to downtown 	<ul style="list-style-type: none"> • Maintain or improve capacity and reliability • Better in-service date certainty
Potential Risks/ Issues	<ul style="list-style-type: none"> • If never energized at 230 kV, incremental costs for 230 kV capability will not provide value 	<ul style="list-style-type: none"> • None if the work is scheduled and completed outside of the peak demand season

Main TS

The IRRP looked at different approaches for addressing end of life assets at Main TS, which include the two step-down transformers and associated medium-voltage switchgear.

Eliminating the station outright was not considered to be a feasible option, as it is over 70 per cent utilized and resupplying the customer demand in the area from adjacent station facilities is not possible with the existing infrastructure.

NWAs, including energy efficiency or DERs, are not suitable options for addressing asset condition-related needs. As an alternative to the step-down station, energy efficiency or DERs would be cost prohibitive as compared to replacing end of life assets.

Other options were considered and are discussed below:

1. **Converting Main TS to 230 kV operation:** Providing a 230 kV connection to Main TS could be achieved by rebuilding the existing 115 kV supply circuits from Leaside TS (H7L and H11L), or by building a new 230 kV line. New 230 kV transformers and associated high-voltage switchgear would be needed at the existing station, or at a new station location. The 115 kV rebuild option would make the existing H7L and H11L circuits unavailable to supply Hearn station from Leaside TS, while building a new 230 kV connection would be very expensive. In addition, as Main TS is space constrained, the larger 230 kV transformers may not be accommodated on the existing site. As property for building a new station in the vicinity is also limited, this alternative was deemed not viable.
2. **Supplying Toronto Hydro's switchgear from new transformers at Warden TS:** As this approach would require the building of several new distribution cable circuits from Warden TS, which is 4.5 km from Main TS, the Working Group determined that this alternative would be expensive, and impractical, considering the number and length of new distribution cables required.
3. **Replacing the transformers at the existing Main TS location with new 115 kV transformers:** This approach is technically feasible and can be accommodated at the existing station location. Given the potential for future high density urban development in the Main TS service area, Toronto Hydro has recommended, that the existing 45/75 MVA transformers at Main TS be replaced with 60/100 MVA transformers. Even with the cost differential between the two transformer sizes – which Hydro One has estimated to be about \$300,000 – the cost of this approach is far less than either option 1 or 2. The Working Group supports this recommendation.

Options 1 and 2 above would have the benefit of shifting load from the 230 kV/ 115 kV autotransformers at Leaside TS to the 230 kV system, providing capacity relief for the Leaside TS autotransformers. Option 3 is the most cost-effective, even with the marginal additional cost of replacing the existing 45/75 MVA transformers with 60/100 MVA transformers.

Table 7-3 summarizes the options assessed to address the end of life asset needs at Main TS.

Table 7-3: Options for Addressing Main TS End-of-life Assets

	Convert to 230 kV	Supply Main TS area from Warden TS	Replace Transformers at Main TS
Summary of Option	<ul style="list-style-type: none"> Replace existing transformers with 230 kV transformers; rebuild the circuits supplying Main TS to 230 kV 	<ul style="list-style-type: none"> Install new 230 kV transformers at Warden TS and supply Main TS service area with new distribution cables from Warden TS 	<ul style="list-style-type: none"> Replace existing transformers at Main TS with new transformers; take the opportunity to install higher capacity transformers to supply future development in the area
Potential Benefits	<ul style="list-style-type: none"> This option would provide relief to the Leaside TS 230 kV /115 kV transformers as it would move Main TS to 230 kV supply 	<ul style="list-style-type: none"> This option would provide relief to the Leaside TS 230 kV/ 115 kV transformers as it would move Main TS to 230 kV supply 	<ul style="list-style-type: none"> This option maximizes use of the existing infrastructure supplying the area Provides capacity for area growth and development
Potential Risks/ Issues	<ul style="list-style-type: none"> The cost would be very high Capacity relief at Leaside TS may only be needed at or beyond the planning horizon Main TS is a small station; this option may not be feasible 	<ul style="list-style-type: none"> The technical feasibility of running very long distribution feeders from Warden to Main TS load is uncertain; there may be reliability impacts The cost would be very high Capacity relief at Leaside TS may only be needed beyond the planning horizon 	<ul style="list-style-type: none"> This option does not provide capacity relief for Leaside TS, which may only be needed beyond the planning horizon Does not preclude upgrading to 230 kV at a later date

C5E/C7E 115 kV underground transmission cables

Given the complexity and lead time required to implement underground infrastructure through downtown Toronto, Hydro One launched an EA process for the cable replacement in May 2018. Community engagement related to the options is currently underway, with five underground routes under consideration. The route investigation will consider stakeholder input, and assess existing easements and rights-of-way, costs, and other technical and environmental considerations. OEB Leave to Construct approval will also be required.

Since the Working Group has determined that there are no suitable alternatives to replacement, this IRRP recommends that Hydro One continue with actions to replace the existing 115 kV cables.

Manby TS

Given the extent of end of life assets at Manby TS, development of a well-coordinated plan will need to consider the capacity of the station to meet future growth needs in Toronto, accommodate additional short-term transfers to the Manby sector in the event of emergencies (such as a loss of Leaside sector supply or PEC outages), and maintain reliability. For example, the plan required to address the assets reaching end of life in the 230 kV switchyard should be coordinated with the remedial action scheme (RAS) recommended in the 2015 Central Toronto IRRP, with the new terminations required to accommodate the new Richview to Manby TS circuits, and the long term need for additional capacity to supply growth in downtown Toronto. NWAs were ruled out as feasible alternatives to address this end of life need.

The Working Group will continue to assess transmission options and develop a recommendation concerning the significant end of life asset needs at Manby TS. It is recommended that this work commence in the RIP.

John TS

The end of life needs at John TS represent a major undertaking that needs to be coordinated with other plans to reinforce step-down supply capacity in the downtown core, including Toronto Hydro's Copeland TS (Phase 1 and Phase 2). For example, Copeland TS will provide an opportunity to review the configuration and major equipment capacity (i.e., right sizing) at John TS, to ensure it meets future needs. Furthermore, the 115 kV station design is in a "ring-

bus” configuration and the end of life need provides an opportunity to review this configuration, while considering costs, operational flexibility, reliability to customers and transmission system development plans in the area.

Coordination of this work with Copeland TS is vital for providing the additional capacity to facilitate outage planning at John TS for the execution of a replacement plan, while maintaining reliable supply in Toronto’s downtown district. Since this need is driven by the condition of the assets, NWAs were ruled out as feasible alternatives to address this end of life need.

The Working Group therefore recommends that the replacement plan for end of life equipment at John TS be further assessed through continued coordinated planning, commencing with the RIP.

Bermondsey TS

The station load is forecast to reach about 173 MW over the study period, after accounting for energy efficiency codes and standards. While there is a continuing requirement for the station to supply customers in the area, the total load on Bermondsey TS is forecasted to remain well below its current capacity over the planning horizon.

The options for addressing the asset end of life need at Bermondsey TS are summarized as follows:

1. **Retire (and decommission) the T3/T4 DESN at its end of life:** This option would mean supplying the entire load at Bermondsey TS from the T1/T2 DESN, and expanding the switchyard to accommodate new feeders (i.e., transferring the 12 feeders from the T3/T4 DESN to the T1/T2 DESN). However, this intra-station transfer would result in the remaining DESN nearing its capacity limit by the end of the study period.
2. **Replace the 84/140 MVA and 75/125 MVA end of life transformers with smaller 50/83 MVA transformers:** According to Hydro One, the cost of feeder work would be significantly more than the \$600,000 savings for smaller size transformers (\$300,000 per transformer).
3. **Replace like for like:** Based on the information available, this option will minimize the cost of end of life work at the station, while retaining some ability to grow and accommodate transfers within the station.

Based on the options put forth, NWAs were screened out at a feasible option to address this end of life need. Further assessment is needed to determine the cost and feasibility of option 2, above. The Working Group therefore recommends that a plan be developed within the scope of the RIP.

7.2 Options for Addressing Supply Capacity Needs

Based on the demand outlook, capacity needs in the Toronto region are centered on a number of transformer stations (DESNs) supplying local neighbourhoods in the city.

Local transformer station capacity needs at Manby TS, Strachan TS, Leslie TS and Wiltshire TS

For the need at Manby TS, the 2015 Central Toronto IRRP recommended that a second DESN be built at the adjacent Horner TS. Part of the rationale for the Horner TS expansion was to provide relief for Manby TS through permanent load transfers. The second DESN is expected to be in-service by late 2021.

The station capacity needs at Strachan TS, Leslie TS and Wiltshire TS are far enough into the future that there is sufficient time to monitor demand changes and revisit these needs in the next planning cycle. Further, based on a preliminary review of possible approaches, capacity is available either at other DESNs within the station, or at adjacent stations to permit planning for load transfers to provide relief to the DESNs that are forecast to reach their capacity. These transfers will require planning and investment to implement.²²

To address the capacity need at Strachan TS, the capacity that is expected to be made available by Copeland TS (Phase 1 and Phase 2) is likely to allow for a permanent load transfer. While the feasibility of implementing such a transfer is not yet clear, there is sufficient time to monitor growth and assess the feasibility of various options. If demand grows faster than anticipated, or the forecast for energy efficiency changes, additional measures to address future capacity needs at Strachan TS – such as energy efficiency or other NWAs – can be explored and implemented, provided they are feasible and cost-effective.

²² These types of actions are normally undertaken by the distributor as part of distribution system planning.

For the needs at Leslie TS and Wiltshire TS, capacity at other DESNs within the station is sufficient to accommodate additional load. This work will be undertaken by Toronto Hydro and Hydro One, with enough lead time to plan and implement intra-station transfers, if and when they are needed.

Local station capacity need at Basin TS

The capacity need at Basin TS arises as early as 2033; however, after considering the impact of efficiency codes and standards, the timing could be deferred to 2040. That said, a number of complicating factors related to the uncertainty of future demand growth at Basin TS must be taken into account. These relate to:

- Planned urban developments at the site and neighbourhood level
- City-led district energy plans
- The potential for economic growth, specifically related to intensification of commercial activity, for example, at the former Unilever site and the film studio district
- The relocation – proposed by the City of Toronto and Waterfront Toronto – of a significant number of existing high-voltage transmission facilities in the area

These uncertainties will impact the scope and timing of the needs, as well as the configuration of the electricity infrastructure in the area, including the ultimate size and location of Basin TS.

Cost-effective NWAs, including DERs and energy efficiency, should be explored to defer the needs at Basin TS, once they are further defined. Ongoing dialogue with stakeholders will be required to help identify feasible and cost-effective solutions, as well as prospective developments that could address the specific characteristics and timing of needs in the area. Since this is driven primarily by the need to supply local customers within Toronto Hydro's service territory, the Working Group agrees that the assessment of NWAs as potential solutions should be coordinated by Toronto Hydro.

7.3 Options for Addressing Regional Supply Capacity Needs

Options to address the regional supply capacity needs identified in Toronto are described below.

Richview TS to Manby TS 230 kV corridor

Options to address this need were assessed in the 2015 Central Toronto IRRP, the 2017 IRRP Addendum and the 2016 RIP by Hydro One. Since then, there have been no material changes to either the scope of the options or the preferred approach, which is planned to occur in the following two phases:

- **Phase One:** Rebuild the existing idle 115 kV overhead line on the transmission corridor between Richview TS and Manby TS to 230 kV. The new line will operate in parallel with the existing four 230 kV circuits from Richview TS to Manby TS, which will initially be reconfigured to create two “supercircuits.” This will allow for the two additional circuits to supply Manby TS, but avoid the need to build new terminations, including new breakers at Manby.
- **Phase Two:** To be coordinated with the Manby TS end of life refurbishment, new circuits will be separately terminated on the Manby 230 kV bus, and at Richview TS they will connect to existing 230 kV circuits between Claireville TS and Richview TS, thereby unbundling the two supercircuits. The scope and timing for this work will be addressed starting with the RIP.

Based on the assessments undertaken by the IESO, the IRRP Working Group recommends that Hydro One proceed with the reinforcement of the Richview TS to Manby TS 230 kV transmission reinforcement project, including initiating community engagement, the EA, and OEB Section 92 Application for Leave to Construct.

Supply capacity at Leaside TS and Manby TS autotransformers, Manby TS to Riverside Junction lines, and Bayview Junction to Balfour Junction circuit section

These regional capacity needs do not emerge until between 2030 and 2040, depending on the assumptions around continued gains in energy efficiency resulting from efficiency codes and standards.

Leaside TS and Manby TS needs are related to the 230 kV/115 kV autotransformer capacity limits. The Manby TS to Riverside Junction line needs are related to the ability to supply the demand when there is a loss of a companion circuit. The Bayview Junction to Balfour Junction

needs emerge in 2040 and are related to the thermal rating of the 115 kV circuit, when there is a loss of the companion circuit.

Cost-effective NWAs, including DERs and energy efficiency, remain possible options to address each of these longer-term regional supply capacity needs. Ongoing engagement with stakeholders and the community will be important for understanding the potential for these types of options going forward. It will also be essential to gather enough information on the nature and timing of these needs to understand what performance and cost attributes NWA options will be required to address them.

7.4 Options for Addressing Discretionary Reliability Needs

These needs are included in Appendix D as discretionary because they represent possible opportunities to maintain and/or enhance the reliability of supply above the minimum performance standards prescribed in ORTAC. Their inclusion in this IRRP recognizes the importance of a reliable electricity supply to an urban centre like Toronto, should feasible, cost-effective options for improving reliability emerge as an outcome of continued planning, coordination, and engagement with electricity sector stakeholders and the community.

Although no specific solution options have been explored in the scope of this plan, these issues should be revisited in future plans, or as other opportunities arise to assess the adequacy and/or resilience of the system, including when assets approach their end of life.

7.5 The Recommended Plan

This IRRP re-affirms the needs and plans identified in the previous regional planning cycle that concluded in January 2016, and recommends the actions described below to address region's transmission needs until at least the late 2020s or early 2030s.

Replace end of life overhead line sections H1L/H3L/H6LC/H8LC and L9C/L12C

Both of these overhead line sections were deemed critical for maintaining a sufficient and reliable supply of electricity to customers in Toronto. The Working Group recommends that Hydro One proceed with planning for the like for like replacement of these overhead line sections.

Replace end of life transformers at Main TS

Both transformers at Main TS are at their end of life and need to be replaced. Considering the potential for future high density urban development in the area, the Working Group recommends that Hydro One proceed with planning to replace the existing transformers with 60/100 MVA transformers.

Continue planning for replacement of C5E/C7E underground transmission cables

When this regional plan was initiated, Hydro One was well into developing options to replace the existing C5E/C7E underground 115 kV cables running between Terauley TS and Esplanade TS in the downtown core. The Working Group recommends that Hydro One continue planning to replace the existing 115 kV cables.

Continue planning to determine end of life approaches for Manby TS, John TS, and Bermondsey TS

Manby TS and John TS: Planning for replacement of these critical electricity assets is a major undertaking that must consider a variety of factors and requires regional coordination. The Working Group recommends that detailed planning for the end of life of these assets continue, starting with the RIP.

Bermondsey TS: The Working Group recommends that the plan to replace the two end of life transformers at Bermondsey TS be completed within the scope of the RIP.

Gather information to inform future capacity planning for Basin TS

Since there is currently insufficient information to characterize the needs at Basin TS and inform specific recommendations in this IRRP, the Working Group proposes that any recommendation on potential solutions be deferred until the next cycle of regional planning, or earlier, as required.

Specifically, the Working Group recommends that Toronto Hydro coordinate continued planning activities related to defining the nature, scope and timing of the future capacity need at Basin TS, and assessment of possible wires and non-wires solutions to address the need. It is expected that this work will involve engaging with key stakeholders, including the City of Toronto and entities responsible for development in the Basin TS area.

If better information about the timing and nature of power system needs in the area indicates there is an urgent need, then Toronto Hydro will inform the Working Group of the need to initiate the next regional planning cycle early.

Proceed with reinforcement of the Richview TS to Manby TS 230 kV corridor

This IRRP re-affirms the need for the Richview TS to Manby TS 230 kV corridor reinforcement that was recommended in the previous regional planning cycle. The Working Group therefore recommends that Hydro One proceed with the reinforcement of the Richview TS to Manby TS 230 kV corridor and begin community engagement, as well as initiate the EA to ensure that the reinforced corridor is in-service as soon as possible.

Keep options available to address long term regional supply capacity needs

The IESO will monitor peak demand annually, along with achievement of energy efficiency and DER uptake, with a particular focus on the areas with forecasted capacity needs. This information will be used to determine when decisions on the long term plan are required, and to inform the next cycle of regional planning for the area. This work will include detailed planning and community engagement to define the needs and associated timing in a manner that will permit the evaluation of possible NWAs as solutions.

The Working Group therefore recommends that the IESO coordinate continued planning work and engagement with stakeholders and the community to define and communicate, as soon as practicable, the longer-term capacity needs; identify opportunities for a range of cost-effective solutions, including DERs and energy efficiency; and identify potential wires solutions and avoidable costs should these needs be deferred through NWAs. The information and insights developed through these activities will be used to inform the next regional planning cycle.

7.5.1 Implementation of Recommended Plan

To ensure that the near term electricity needs of the Toronto region are addressed, plan recommendations will need to be implemented as soon as possible. Specific actions and deliverables are outlined in Table 7-4, along with the recommended timing.

Table 7-4: Summary of Needs and Recommended Actions in Toronto Region

Need	Recommended Action(s)/Deliverable(s)	Lead Responsibility	Time frame/ Need Date
End-of-life of overhead line sections H1L / H3L / H6LC / H8LC and L9C / L12C	Proceed with replacement as needed to meet identified timelines	Hydro One	2022-2033 for HxL/HxLC circuits; 2023-2024 for LxC circuits
End-of-life of Main TS transformers, 115 kV disconnect switches and 115 kV current voltage transformers	Proceed with replacement as needed to meet identified timelines	Hydro One	2021-2022
End-of-life of C5E / C7E underground transmission cables	Continue with EA, and proceed with replacement to meet identified timelines	Hydro One	2024-2025
End-of-life assets at Manby TS, John TS and Bermondsey TS	Continue with detailed planning to make a decision in time to address the need; initiate in the Regional Infrastructure Plan	Working Group	2025-2027
Capacity to supply projected load at Manby TS	Continue with implementation of Horner TS expansion to provide relief	Hydro One	2021
Capacity to supply projected load at Basin TS	Continue to gather information to inform assessment of future need and timing; engage with key stakeholders; trigger regional planning if necessary	Toronto Hydro	2019 to next planning cycle
Richview to Manby TS 230 kV reinforcement	Initiate EA work, community engagement, and OEB Section 92 Application	Hydro One	2021 or as soon as possible

Need	Recommended Action(s)/Deliverable(s)	Lead Responsibility	Time frame/ Need Date
Leaside TS and Manby TS autotransformer capacity; Manby TS to Riverside Junction; and Bayview Junction to Balfour Junction	Further define characteristics of longer-term needs; define information needed from local stakeholders; identify DER and energy efficiency potential; develop wires-based alternatives; assess and compare wires and NWAs	IESO	2019 to next planning cycle

8. Community and Stakeholder Engagement

Community engagement is an integral component of the regional planning process. Providing opportunities for input in regional planning enables the views and preferences of the community to be considered in the development of an IRRP and helps lay the foundation for successful implementation. This section outlines the engagement principles and activities undertaken for the Toronto IRRP.

8.1 Engagement Principles

The IESO's Engagement Principles²³ guided the process to help ensure that all interested parties were aware of and could contribute to the development of this IRRP. The IESO uses these principles to ensure inclusiveness, sincerity, respect and fairness in its engagements, and to support its efforts to build trusted relationships.

Figure 9-1: IESO Engagement Principles

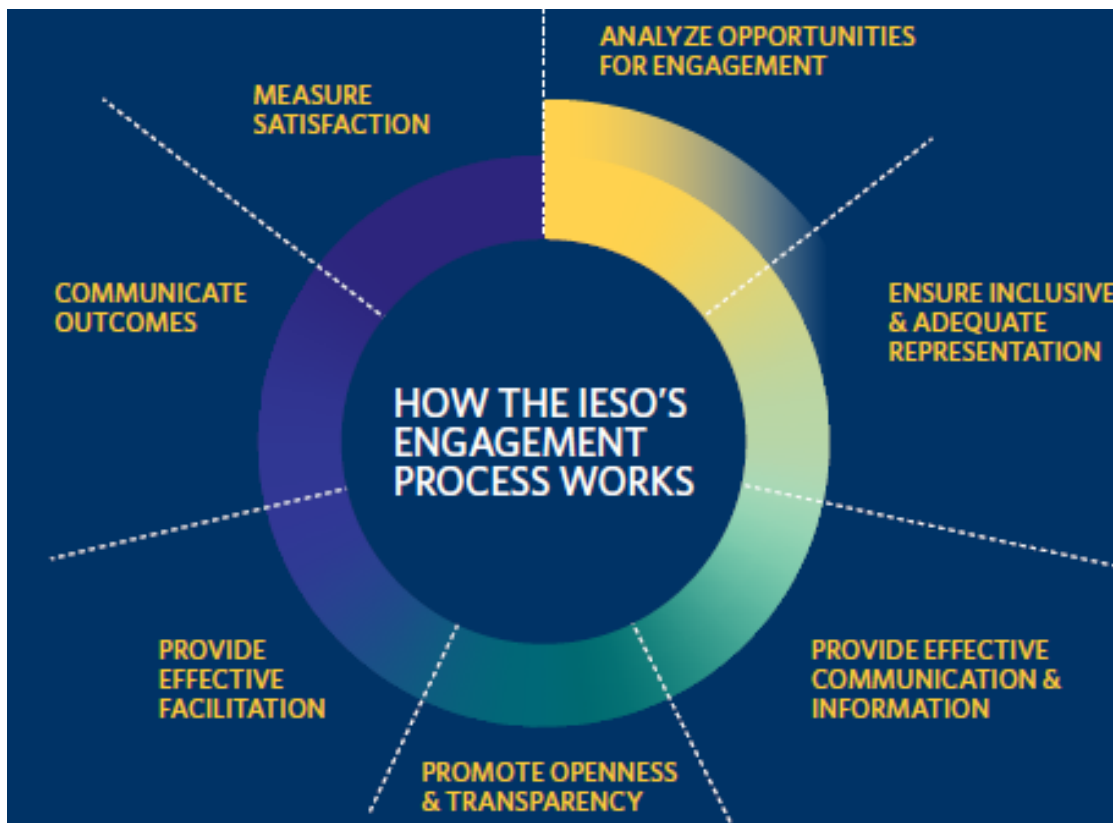

²³ <http://www.ieso.ca/Sector-Participants/Engagement-Initiatives/Overview/Engagement-Principles>

8.2 Creating an Engagement Approach

The outreach and engagement approach was designed to ensure the IRRP reflected input from key community and stakeholder representatives. A dedicated engagement web page²⁴ was also created to provide openness and transparency throughout the engagement process. This web page hosted all engagement activities, including background information, presentations and public meetings/webinars on the development of this IRRP, as well as previous plans for the area.

The IESO's email subscription service for the Toronto planning region was used to send information to interested communities and stakeholders who subscribed to receive updates. Targeted outreach to municipalities, Indigenous communities and other business sectors in the region was also conducted at the outset of this engagement and continued throughout the planning process.

In addition, regular communications were sent via the IESO's weekly Bulletin, which has subscribers from across Ontario's electricity sector.

8.3 Engage Early and Often

Leveraging relationships built during the previous planning cycle, the IESO held preliminary discussions to help inform the engagement approach during this second planning cycle – starting with the Scoping Assessment Outcome Report.

Early communication and engagement activities for the Toronto IRRP began with invitations to all subscribers and targeted communities to learn about and provide comments on the draft Toronto Region Scoping Assessment Outcome Report before it was finalized in February 2018. This scoping assessment identified the need for an IRRP for the Toronto region and included terms of reference to guide development of the plan. Following feedback, and the IESO's response to feedback – both of which are posted on the engagement web page – the final Scoping Assessment Outcome Report was also published.

Outreach then began with targeted communities to inform early discussions for the development of the IRRP. The launch of a broader engagement initiative followed with an

²⁴ <http://ieso.ca/Sector-Participants/Engagement-Initiatives/Engagements/Integrated-Regional-Resource-Plan-Toronto>

invitation to subscribers to ensure that all interested parties were made aware of this opportunity for input.

A public engagement meeting, held to give interested parties an opportunity to learn about the draft IRRP and provide comments, attracted a cross-representation of stakeholder and community representatives. Following a 14-day comment period, no further comments were received for consideration during the development of the IRRP.

As a final step in this engagement, all participating parties were invited to comment on the proposed recommendations in this IRRP. Comments received during the engagement meeting and in response to the proposed recommendations related to six major themes:

1. Non-wires alternatives
2. Considerations to inform future electricity needs in electricity system planning
3. Electrification (e.g., electric vehicles)
4. Costs of the electricity system
5. Composition of the technical working group
6. Engagement/education

Based on this feedback, it is clear that there is a strong need for ongoing monitoring of capacity and local demand growth, as well as continued discussion and engagement with communities and stakeholders. While needs do not start to emerge until the 2030s or later, the IESO recognizes the importance of sustained dialogue to ensure alignment with local priorities, initiatives and developments. The full submissions can be found on the IESO's website. Responses to specific feedback are provided as Appendix G: Responses to Public Feedback on Proposed Recommendations.

All background information, including engagement presentations and recorded webinars, are available on the IESO's Integrated Regional Resource Plan engagement web page.

8.4 Outreach with Municipalities

As the City of Toronto was a key stakeholder in the development of this IRRP, the IESO held a number of meetings with city representatives to seek input on municipal planning and to ensure that the city's plans were taken into consideration. Meetings began in June 2018 at the outset of these discussions and continued in April and May 2019. These meetings helped to inform the city's electricity needs and provided opportunities to strengthen this relationship for ongoing dialogue beyond this IRRP process.

9. Conclusion

This report documents an IRRP that has been developed for the Toronto region, and identifies regional electricity needs and opportunities to preserve or enhance electricity system reliability in Toronto from 2019 to 2040. The IRRP makes recommendations to address near term issues, and lays out actions to monitor, defer, and address long term needs.

To further review “wires” solutions that address end of life asset replacement and other transmission supply needs, the Working Group recommends that Hydro One initiate an RIP. The IESO will continue to provide input and support throughout the RIP process, and assist with any regulatory matters arising during plan implementation.

To support the development of the plan, this IRRP includes recommendations with respect to developing alternatives, monitoring load growth and efficiency achievements, and evaluating DER potential and value in the region. Responsibility for these actions has been assigned to the appropriate members of the Working Group. Information gathered and lessons learned as a result of these activities will inform development of the next iteration of the regional plan for the Toronto region.

The Toronto region Working Group will continue to meet at regular intervals to monitor developments and track progress toward plan deliverables. In the event that underlying assumptions change significantly, local plans may be revisited through an amendment, or by initiating a new regional planning cycle sooner than the five-year schedule mandated by the OEB.



Toronto

REGIONAL INFRASTRUCTURE PLAN

March 6, 2020



(This page is intentionally left blank)

Prepared and supported by:

Company
Alectra Utilities Corporation
Elexicon Energy Inc.
Hydro One Networks Inc. (Distribution)
Independent Electricity System Operator (IESO)
Toronto Hydro-Electric System Limited
Hydro One Networks Inc. (Lead Transmitter)



DISCLAIMER

This Regional Infrastructure Plan (“RIP”) report was prepared for the purpose of developing an electricity infrastructure plan to address all near and mid-term needs identified in previous planning phases and any additional needs identified based on new and/or updated information provided by the RIP Study Team.

The preferred solution(s) that have been identified in this report may be reevaluated based on the findings of further analysis. The load forecast and results reported in this RIP report are based on the information provided and assumptions made by the participants of the RIP Study Team.

Study Team participants, their respective affiliated organizations, and Hydro One Networks Inc. (collectively, “the Authors”) make no representations or warranties (express, implied, statutory or otherwise) as to the RIP report or its contents, including, without limitation, the accuracy or completeness of the information therein and shall not, under any circumstances whatsoever, be liable to each other, or to any third party for whom the RIP report was prepared (“the Intended Third Parties”), or to any other third party reading or receiving the RIP report (“the Other Third Parties”), for any direct, indirect or consequential loss or damages or for any punitive, incidental or special damages or any loss of profit, loss of contract, loss of opportunity or loss of goodwill resulting from or in any way related to the reliance on, acceptance or use of the RIP report or its contents by any person or entity, including, but not limited to, the aforementioned persons and entities.

EXECUTIVE SUMMARY

THIS REGIONAL INFRASTRUCTURE PLAN (“RIP”) WAS PREPARED BY HYDRO ONE WITH SUPPORT FROM THE RIP STUDY TEAM IN ACCORDANCE TO THE ONTARIO TRANSMISSION SYSTEM CODE REQUIREMENTS. IT IDENTIFIES INVESTMENTS IN TRANSMISSION FACILITIES, DISTRIBUTION FACILITIES, OR BOTH, THAT SHOULD BE DEVELOPED AND IMPLEMENTED TO MEET THE ELECTRICITY INFRASTRUCTURE NEEDS WITHIN THE TORONTO REGION.

The participants of the Regional Infrastructure Plan (“RIP”) Study Team included members from the following organizations:

- Alectra Utilities (“Alectra”)
- Elexicon Energy Inc. (“Elexicon”)
- Hydro One Networks Inc. (Distribution)
- Independent Electricity System Operator (“IESO”)
- Toronto Hydro-Electric System Limited (“THESL”)
- Hydro One Networks Inc. (Transmission)

This RIP is the final phase of the second cycle of Toronto regional planning process, which follows the completion of the Toronto Integrated Regional Resource Plan (“IRRPP”) in August 2019 and the Toronto Region Needs Assessment (“NA”) in October 2017. This RIP provides a consolidated summary of the needs and recommended plans for Toronto Region over the planning horizon (1 – 20 years) based on available information.

This RIP discusses needs identified in the previous regional planning cycle, the Needs Assessment and IRRP reports for this cycle, and wires solutions recommended to address these needs. Implementation plans to address some of these needs are already completed or are underway. Since the previous regional planning cycle, the following projects have been completed:

- Midtown Transmission Reinforcement Project (completed in 2016)
- Clare R. Copeland 115 kV Switching Station and Copeland MTS (completed in 2019)
- Manby SPS Load Rejection (L/R) Scheme (completion in 2019)

The major infrastructure investments recommended by the Study Team in the near and mid-term planning horizon are provided in the Table 1 below, along with their planned in-service date and budgetary estimates for planning purpose.

Table 1. Recommended Plans in Toronto Region over the Next 10 Years

No.	Need	Recommended Action Plan	Planned I/S Date	Budgetary Estimate ⁽¹⁾
1	Main TS: End-of-life of transformers T3/T4	Replace the end-of-life transformers with similar type and size equipment as per current standard	2021	\$33M
2	H1L/H3L/H6LC/H8LC: End-of-life of Leaside Jct. to Bloor St. Jct. overhead section	Refurbish the end-of-life H1L/H3L/H6LC/H8LC section	2023	\$11M
3	L9C/L12C: End-of-life of Leaside TS to Balfour Jct. overhead section	Refurbish the end-of-life L9C/L12C section	2023	\$3M
4	C5E/C7E: End-of-life of underground cables between Esplanade TS and Terauley TS	Replace the end-of-life C5E/C7E cables	2024	\$128M
5	Richview TS to Manby TS 230 kV Corridor Reinforcement	Replace existing idle 115 kV double circuit line with new 230 kV double circuit line between Richview TS and Manby TS	2023	\$21M
6	Manby TS: End-of-life of autotransformers (T7, T9, T12), step-down transformer (T13), and the 230 kV switchyard	Replace the end-of-life transformers with similar type and size equipment as per current standard, and refurbish/reconfigure Manby 230 kV switchyard	2025	\$85M
7	Bermondsey TS: End-of-life of transformers T3/T4	Replace the end-of-life transformers with similar type and size equipment as per current standard	2025	\$27M
8	John TS: End-of-life of transformers (T1, T2, T3, T4, T5, T6), 115 kV breakers, and LV switchgear	Replace with similar type and size equipment as per current standard	2026	\$102M

(1) Budgetary estimates are provided for Hydro One's portion of the work

The Study Team recommends that:

- Hydro One to continue with the implementation of infrastructure investments listed in Table 1 while keeping the Study Team apprised of project status;
- All the other identified needs/options in the long-term will be further reviewed by the Study Team in the next regional planning cycle.

TABLE OF CONTENTS

Disclaimer	4
Executive Summary	5
Table of Contents	7
1 Introduction.....	9
1.1 Objectives and Scope	9
1.2 Structure	10
2 Regional Planning Process.....	11
2.1 Overview.....	11
2.2 Regional Planning Process.....	11
2.3 RIP Methodology	13
3 Regional Characteristics	15
4 Transmission Facilities/Projects Completed and/or Underway Over the Last Ten Years	18
5 Load Forecast and Study Assumptions	20
5.1 Load Forecast.....	20
5.2 Study Assumptions	20
6 Adequacy of Existing Facilities	22
6.1 230 kV Transmission Facilities.....	22
6.2 230/115 kV Autotransformers Facilities.....	23
6.3 115 kV Transmission Facilities.....	23
6.4 Step-Down Transformer Station Facilities.....	24
6.5 Longer Term Outlook (2030-2040)	25
7 Regional Needs and Plans.....	27
7.1 Main TS: End-of-Life Transformers.....	28
7.2 H1L/H3L/H6LC/H8LC: End-of-Life Overhead Section (Leaside 34 Jct. to Bloor St. Jct.).....	30
7.3 L9C/L12C: End-of-Life Overhead Section (Leaside TS to Balfour Jct.)	31
7.4 C5E/C7E: End-of-Life Underground Cables (Esplanade TS to Terauley TS)	32
7.5 Richview TS to Manby TS 230 kV Corridor	34
7.6 Manby TS: End-of-Life Transformers and 230 kV Switchyard	36
7.7 Bermondsey TS: End-of-Life Transformers	37
7.8 John TS: End-of-Life Transformers, 115 kV Breakers, and LV Switchgear.....	39
7.9 Long-Term Capacity Needs	41
8 Conclusions and Next Steps.....	44
9 References.....	46
Appendix A. Stations in the Toronto Region.....	47
Appendix B. Transmission Lines in the Toronto Region	50
Appendix C. Distributors in the Toronto Region.....	51
Appendix D. Toronto Region Load Forecast.....	53

List of Figures

Figure 1-1: Toronto Region Map	9
Figure 2-1: Regional Planning Process Flowchart.....	13
Figure 2-2: RIP Methodology	14
Figure 3-1: Single Line Diagram of Toronto Region’s Transmission Network	16
Figure 5-1: Toronto Region Load Forecast.....	20
Figure 7-1: Main TS.....	29
Figure 7-2: H1L/H3L/H6LC/H8LC Section between Leaside 34 Jct. and Bloor St. Jct.	30
Figure 7-3: L9C/L12C Section between Leaside TS and Balfour Jct.....	31
Figure 7-4: C5E/C7E Underground Cable Section between Esplanade TS and Terauley TS	33
Figure 7-5: Richview TS to Manby TS 230 kV Corridor	34
Figure 7-6: Richview TS to Manby TS 230 kV Corridor – Phase 1.....	35
Figure 7-7: Richview TS to Manby TS 230 kV Corridor – Phase 2.....	36
Figure 7-8: Manby TS.....	37
Figure 7-9: Bermondsey TS and Surrounding Stations	38
Figure 7-10: John TS	39

List of Tables

Table 6-1: New Facilities Assumed In-Service	22
Table 6-2: Toronto Step-Down Transformer Stations	25
Table 6-3: Longer Term Adequacy of Transmission Facilities	25
Table 6-4: Longer Term Adequacy of Step-Down Transformer Stations	26
Table 7-1: Identified Near and Mid-Term Needs in Toronto Region	27
Table 7-2: Identified Long-Term Needs in Toronto Region.....	28
Table 8-1: Recommended Plans in Toronto Region over the Next 10 Years	44
Table D-1: Toronto IRRP Load Forecast, without the Impacts of Energy-Efficiency Savings.....	53
Table D-2: Toronto Non-Coincident Load Forecast, without the Impacts of Energy-Efficiency Savings .	54
Table D-3: Toronto IRRP Load Forecast, with the Impacts of Energy-Efficiency Savings.....	55
Table D-4: Toronto Non-Coincident Load Forecast, with the Impacts of Energy-Efficiency Savings	56

1 INTRODUCTION

THIS REPORT PRESENTS THE REGIONAL INFRASTRUCTURE PLAN (“RIP”) TO ADDRESS THE ELECTRICITY NEEDS OF THE TORONTO REGION BETWEEN 2019 AND 2039.

The report was prepared by Hydro One Networks Inc. (Transmission) (“Hydro One”) on behalf of the Study Team that consists of Hydro One, Alectra Utilities (“Alectra”), Elexicon Energy Inc. (“Elexicon”), Hydro One Networks Inc. (Distribution), the Independent Electricity System Operator (“IESO”), and Toronto Hydro-Electric System Limited (“THESL”) in accordance with the new Regional Planning process established by the Ontario Energy Board in 2013.

The Toronto Region is comprised of the area within the municipal boundary of the City of Toronto. Electrical supply to the region is provided by thirty-five 230 kV and 115 kV step-down transformer stations (“TS”) as shown in Figure 1-1. The outer parts of the region to the east, north, and west are supplied by fifteen 230/27.6 kV and two 230/27.6-13.8 kV step-down transformer stations. The central area is supplied by two 230/115 kV autotransformer stations at Leaside TS and Manby TS, and sixteen 115/13.8 kV and two 115/27.6 kV step-down transformer stations.

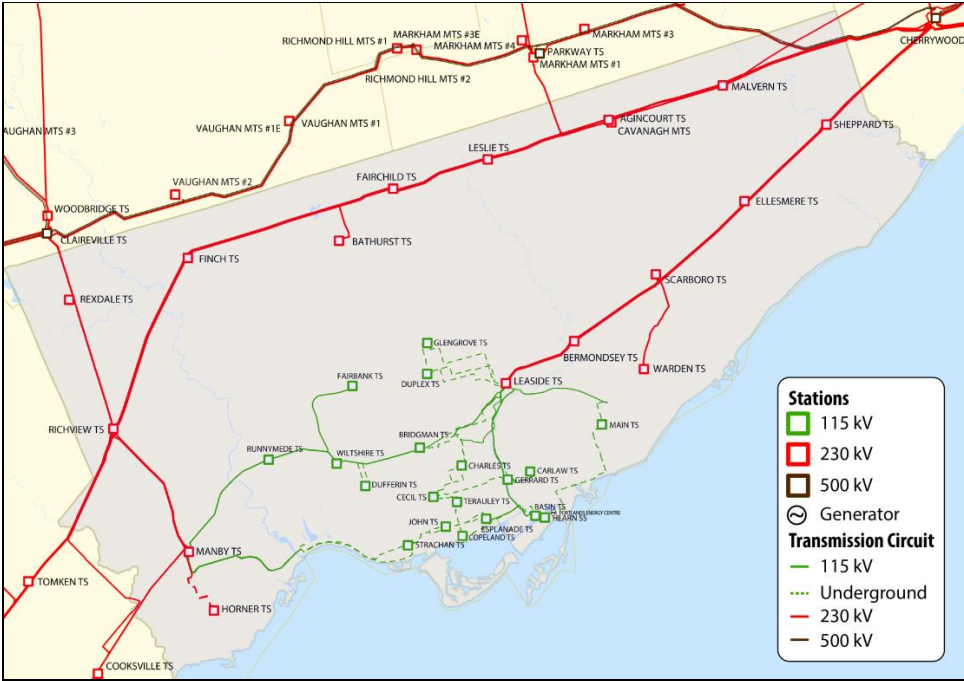

Figure 1-1: Toronto Region Map

1.1 Objectives and Scope

The RIP report examines the needs in the Toronto Region. Its objectives are to:

- Provide a comprehensive summary of needs and wires plans to address the needs;

- Identify any new needs that may have emerged since previous planning phases e.g., Needs Assessment (“NA”), Scoping Assessment (“SA”), and/or Integrated Regional Resource Plan (“IRRP”);
- Assess and develop a wires plan to address these needs; and
- Identify investments in transmission and distribution facilities or both that should be developed and implemented on a coordinated basis to meet the electricity infrastructure needs within the region.

The RIP reviewed factors such as the load forecast, major high voltage sustainment issues emerging over the near, mid- and long-term horizon, transmission and distribution system capability along with any updates to local plans, conservation and demand management (“CDM”) forecasts, renewable and non-renewable generation development, and other electricity system and local drivers that may impact the need and alternatives under consideration.

The scope of this RIP is as follows:

- A consolidated report of the relevant wires plans to address near and medium-term needs identified in previous planning phases (Needs Assessment, Scoping Assessment, and/or Integrated Regional Resource Plan);
- Discussion of any other major transmission infrastructure investment plans over the planning horizon;
- Identification of any new needs and a wires plan to address these needs based on new and/or updated information;
- Develop a plan to address any longer term needs identified by the Study Team.

1.2 Structure

The rest of the report is organized as follows:

- Section 2 provides an overview of the regional planning process.
- Section 3 describes the regional characteristics.
- Section 4 describes the transmission work completed over the last ten years.
- Section 5 describes the load forecast and study assumptions used in this assessment.
- Section 6 describes the adequacy of the transmission facilities in the region over the study period.
- Section 7 discusses the needs and provides the alternatives and preferred solutions.
- Section 8 provides the conclusion and next steps.

2 REGIONAL PLANNING PROCESS

2.1 Overview

Planning for the electricity system in Ontario is done at three levels: bulk system planning, regional system planning, and distribution system planning. These levels differ in the facilities that are considered and the scope of impact on the electricity system. Planning at the bulk system level typically looks at issues that impact the system on a provincial level, while planning at the regional and distribution levels looks at issues on a more regional or localized level.

Regional planning looks at supply and reliability issues at a regional or local area level. Therefore, it largely considers the 115 kV and 230 kV portions of the power system that supply various parts of the province.

2.2 Regional Planning Process

A structured regional planning process was established by the Ontario Energy Board (“OEB”) in 2013 through amendments to the Transmission System Code (“TSC”) and Distribution System Code (“DSC”). The process consists of four phases: the Needs Assessment ¹ (“NA”), the Scoping Assessment (“SA”), the Integrated Regional Resource Plan (“IRRP”), and the Regional Infrastructure Plan (“RIP”).

The regional planning process begins with the NA phase, which is led by the transmitter to determine if there are regional needs. The NA phase identifies the needs and the Study Team determines whether further regional coordination is necessary to address them. If no further regional coordination is required, further planning is undertaken by the transmitter and the impacted local distribution company (“LDC”) or customer and develops a Local Plan (“LP”) to address them.

In situations where identified needs require coordination at the regional or sub-regional levels, the IESO initiates the SA phase. During this phase, the IESO, in collaboration with the transmitter and impacted LDCs, reviews the information collected as part of the NA phase, along with additional information on potential non-wires alternatives, and makes a decision on the most appropriate regional planning approach. The approach is either a RIP, which is led by the transmitter, or an IRRP, which is led by the IESO. If more than one sub-region was identified in the NA phase, it is possible that a different approach could be taken for different sub-regions.

The IRRP phase will generally assess infrastructure (wires) versus resource (CDM and Distributed Generation) options at a higher or more macro level, but sufficient to permit a comparison of options. If the IRRP phase identifies that infrastructure options may be most appropriate to meet a need, the RIP phase will conduct detailed planning to identify and assess the specific wires alternatives and recommend a preferred wires solution. Similarly, resource options that the IRRP identifies as best suited to meet a need are then further planned in greater detail by the IESO. The IRRP phase also includes IESO led stakeholder engagement with municipalities, Indigenous communities, business sectors and other interested stakeholders in the region.

¹ Also referred to as Needs Screening

The RIP phase is the fourth and final phase of the regional planning process and involves: discussion of previously identified needs and plans; identification of any new needs that may have emerged since the start of the planning cycle; and development of a wires plan to address the needs where a wires solution would be the best overall approach. This phase is led and coordinated by the transmitter and the deliverable is a comprehensive report of a wires plan for the region. Once completed, this report is also referenced in transmitter's rate filing submissions and as part of LDC rate applications with a planning status letter provided by the transmitter.

To efficiently manage the regional planning process, Hydro One has been undertaking wires planning activities in collaboration with the IESO and/or LDCs for the region as part of and/or in parallel with:

- Planning activities that were already underway in the region prior to the new regional planning process taking effect;
- The NA, SA, and LP phases of regional planning;
- Participating in and conducting wires planning as part of the IRRP for the region or sub-region;
- Working and planning for connection capacity requirements with the LDCs and transmission connected customers.

Figure 2-1 illustrates the various phases of the regional planning process (NA, SA, IRRP, and RIP) and their respective phase trigger, lead, and outcome.

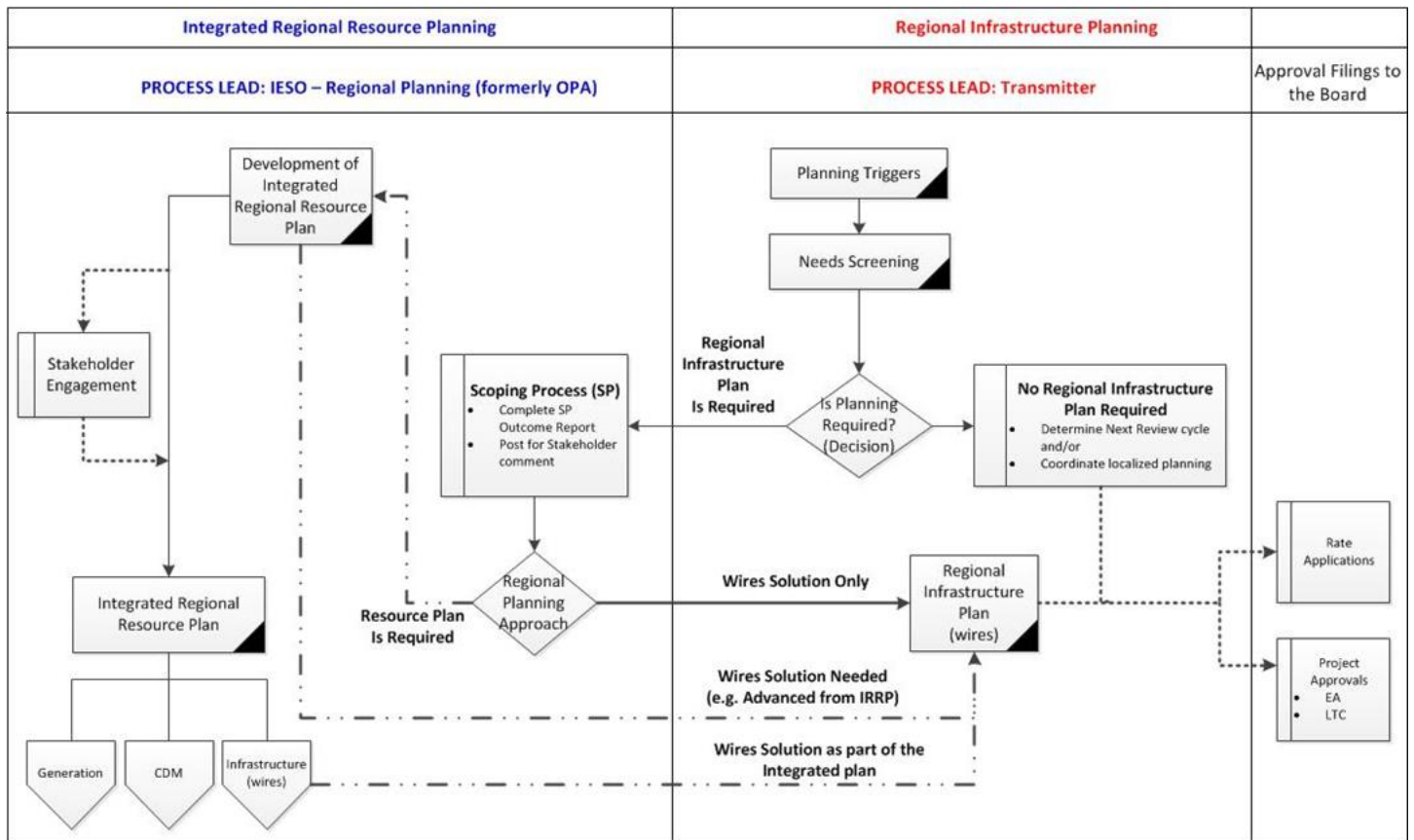

Figure 2-1: Regional Planning Process Flowchart

2.3 RIP Methodology

The RIP phase consists of a four step process (see Figure 2-2) as follows:

- 1) **Data Gathering:** The first step of the process is the review of planning assessment data collected in the previous phase of the regional planning process. Hydro One collects this information and reviews it with the Study Team to reconfirm or update the information as required. The data collected includes:
 - Net peak demand forecast at the transformer station level. This includes the effect of any distributed generation or conservation and demand management programs.
 - Existing area network and capabilities including any bulk system power flow assumptions.
 - Other data and assumptions as applicable such as asset conditions; load transfer capabilities, and previously committed transmission and distribution system plans.
- 2) **Technical Assessment:** The second step is a technical assessment to review the adequacy of the regional system including any previously identified needs. Depending upon the changes to load forecast or other relevant information, regional technical assessment may or may not be required

or be limited to specific issue only. Additional near and mid-term needs may be identified in this phase.

- 3) Alternative Development: The third step is the development of wires options to address the needs and to come up with a preferred alternative based on an assessment of technical considerations, feasibility, environmental impact and costs.
- 4) Implementation Plan: The fourth and last step is the development of the implementation plan for the preferred alternative.

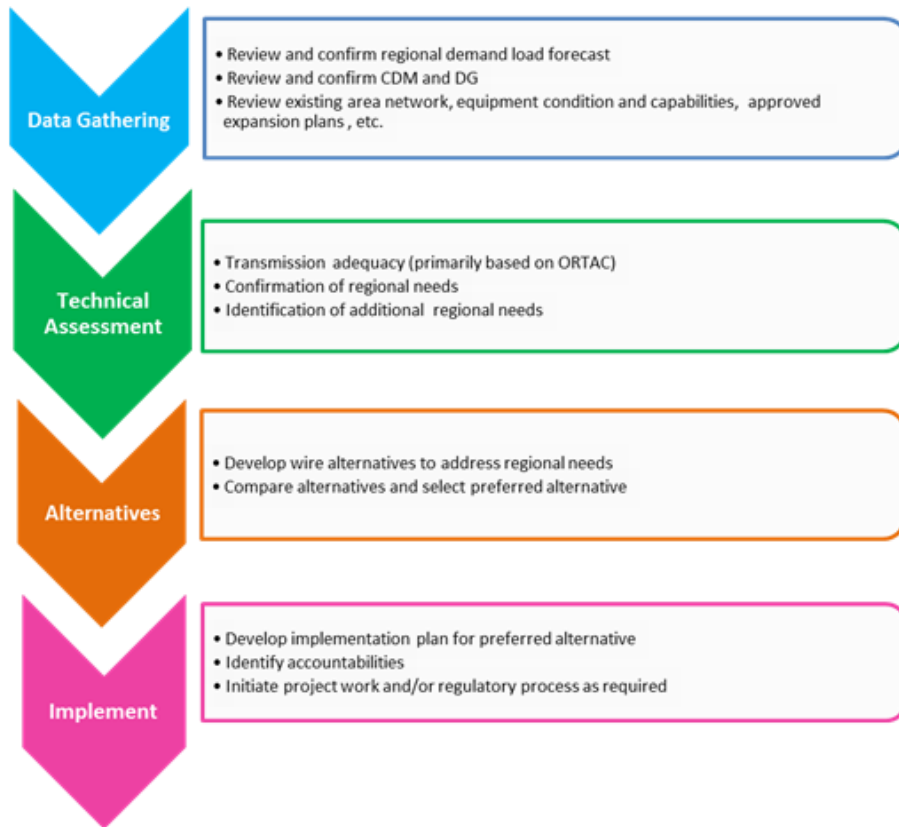

Figure 2-2: RIP Methodology

3 REGIONAL CHARACTERISTICS

THE TORONTO REGION INCLUDES THE AREA ROUGHLY BORDERED GEOGRAPHICALLY BY LAKE ONTARIO ON THE SOUTH, STEELES AVENUE ON THE NORTH, HIGHWAY 427 ON THE WEST, AND REGIONAL ROAD 30 ON THE EAST. IT CONSISTS OF THE CITY OF TORONTO, WHICH IS THE LARGEST CITY IN CANADA AND THE FOURTH LARGEST IN NORTH AMERICA.

Bulk electrical supply to the Toronto Region is provided through three 500/230 kV transformers stations at Claireville TS, Cherrywood TS, and Parkway TS and a network of 230 kV and 115 kV transmission lines and step-down transformation facilities. Local generation in the area consists of the 550 MW Portlands Energy Centre located near the Downtown area and connected to the 115 kV network at Hearn Switching Station (“SS”). The Toronto Region summer coincident peak demand in 2018 was about 4,660 MW which represents about 20% of the gross total demand (23240 MW) in the province.

Toronto Hydro-Electric System Limited (“THESL”) is the main Local Distribution Company (“LDC”) which serves the electricity demand in the Toronto Region. Other LDCs supplied from electrical facilities in the Toronto Region are Hydro One Networks Inc. Distribution, Alectra Utilities and Elexicon Energy Inc. The LDCs receive power at the step-down transformer stations and distribute it to the end-users – industrial, commercial and residential customers.

A single line diagram showing the electrical facilities of the Toronto Region is provided in Figure 3-1. Copeland MTS is a new THESL owned transformer station which serves the Downtown area and came into service in Q1 2019.

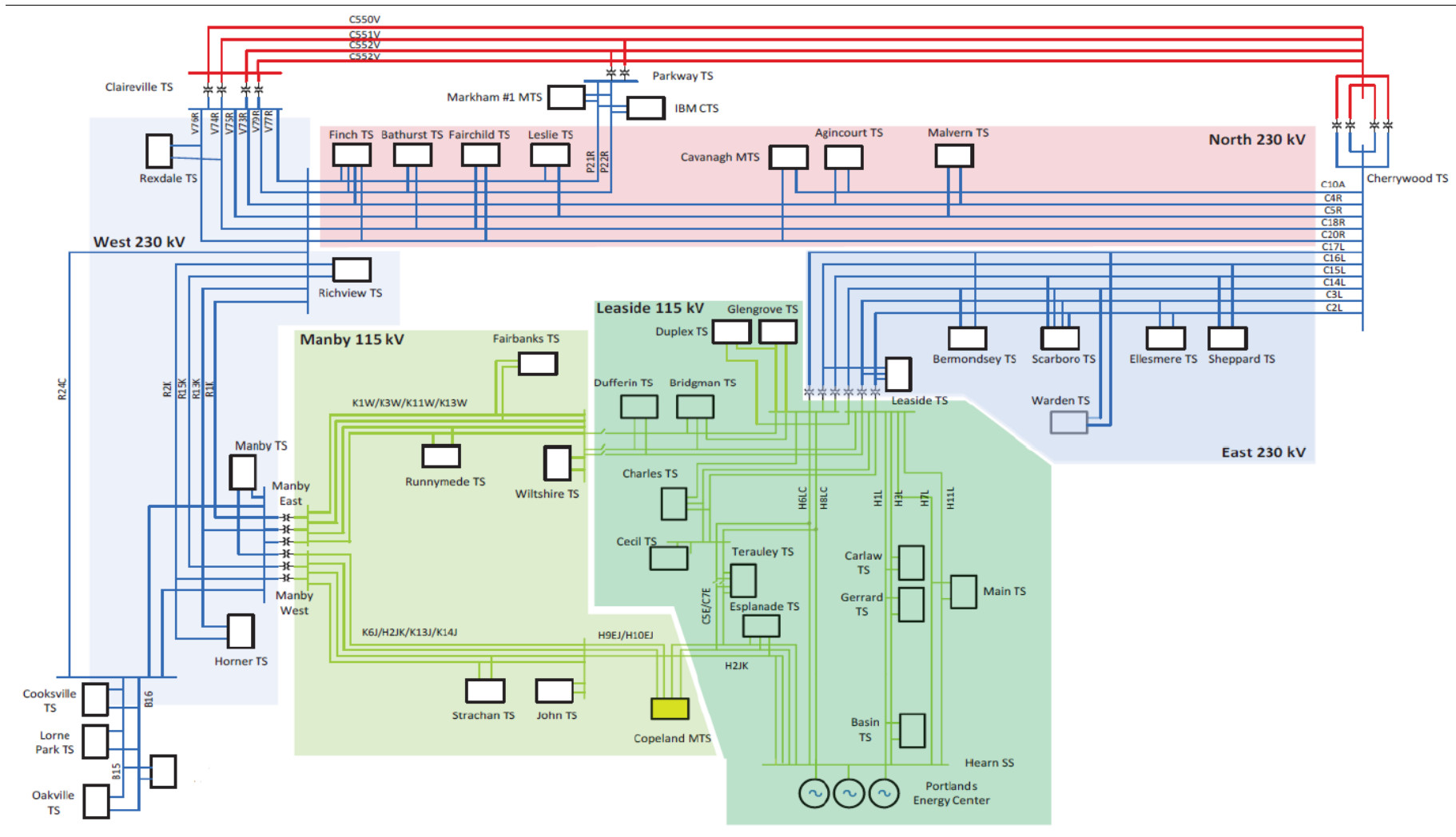

Figure 3-1: Single Line Diagram of Toronto Region's Transmission Network

The thirty-five Toronto's transformer stations can be grouped into five electrical zones based on their HV supply network:

1. **Leaside 115 kV Area:** The transformer stations in this area are supplied by the Leaside TS 230/115 kV autotransformers, and serve roughly the customers in the eastern part of Central Toronto. A list of the transformer stations in this area is provided below.
 - Basin TS
 - Cecil TS
 - Duplex TS
 - Glengrove TS
 - Bridgman TS
 - Charles TS
 - Esplanade TS
 - Main TS
 - Carlaw TS
 - Dufferin TS
 - Gerrard TS
 - Terauley TS

2. **Manby 115 kV Area:** This area covers the western part of Central Toronto which is supplied by the Manby TS 230/115 kV autotransformers. The transformer stations in this area is listed below.
 - Copeland MTS
 - John TS
 - Strachan TS
 - Fairbank TS
 - Runnymede TS
 - Wiltshire TS

3. **East 230 kV Area:** This area includes transformer stations connected to the 230 kV circuits between Cherrywood TS and Leaside TS C2L/C3L, C14L/C15L, and C16L/C17L, serving customers in the outer-eastern part of Toronto and Scarborough areas. Below are the transformer stations in East 230 kV area.
 - Bermondsey TS
 - Leaside TS
 - Sheppard TS
 - Ellesmere TS
 - Scarboro TS
 - Warden TS

4. **North 230 kV Area:** This area covers the outer northern part of Toronto bordering the York Region. The transformer stations in this area, listed below, are supplied by the 230kV circuits connecting Richview TS, Cherrywood TS, and/or Parkway TS C4R/C5R, C18R/C20R, P21R/P22R.
 - Agincourt TS
 - Fairchild TS
 - Leslie TS
 - Bathurst TS
 - Finch TS
 - Malvern TS
 - Cavanagh MTS

5. **West 230 kV Area:** The transformer stations in this area serve customers in the outer western part of Toronto including Etobicoke, and includes stations supplied by the Claireville TS to Richview TS 230 kV circuits V73R/V74R/V75R/V76R/V77R/V79R and the Richview TS to Manby TS 230 kV circuits R1K/R2K and R13K/R15K. Below are the transformer stations in West 230 kV area.
 - Horner TS
 - Rexdale TS
 - Manby TS
 - Richview TS

4 TRANSMISSION FACILITIES/PROJECTS COMPLETED AND/OR UNDERWAY OVER THE LAST TEN YEARS

OVER THE LAST TEN YEARS, A NUMBER OF TRANSMISSION PROJECTS HAVE BEEN PLANNED AND UNDERTAKEN BY HYDRO ONE AIMED TO MAINTAIN THE RELIABILITY AND ADEQUACY OF ELECTRICITY SUPPLY TO THE TORONTO REGION.

A summary and description of the major projects completed and/or currently underway over the last ten years is provided below.

- Incorporation of the 550 MW Portland's Energy Centre (2009) – Covered modification to the Hearn 115 kV switchyard to connect the new generation.
- 115 kV Switchyard Work at Hearn SS, Leaside TS, and Manby TS (2013, 2014) – Includes replacement of the aging 115 kV switchyard at Hearn SS with a new gas-insulated switchgear (“GIS”) and replacement of all 115 kV oil breakers at Leaside TS and Manby TS.
- Manby 230 kV Reconfiguration (2014) – Re-tapped Horner TS from the circuit R15K to R13K at Manby TS to balance and improve the distribution of loading on the 230 kV Richview TS to Manby TS system.
- Lakeshore Cable Refurbishment project (2015) – Covered replacement of the aging K6J/H2JK 115 kV circuits between Riverside Jct. and Strachan TS.
- Midtown Transmission Reinforcement Project (completed in 2016) – Covered replacement of the aging L14W underground cable and addition of a new 115 kV circuit between Leaside TS and Bridgman TS.
- Clare R. Copeland 115 kV Switching Station (completed in 2019) – Built to connect a new THESL owned 115/13.8 kV step-down transformer station (Copeland MTS) in Downtown Toronto.
- Runnymede TS DESN#2 and Manby TS to Wiltshire TS Circuits Upgrade Project (2018) – covered building of a second 50/83MVA, 115/27.6kV DESN at Runnymede TS and reinforcement of the Manby TS to Wiltshire TS 115kV circuits to accommodate increasing load demand in the area.
- Manby SPS Load Rejection (L/R) Scheme (2019) – Built to ensure that loading on in-service equipment at Manby TS is not exceeded for loss of two out of three autotransformers in the Manby East TS and Manby West switchyards.

- Horner TS DESN #2 Project (2022) – covers construction of a second 75/125MVA, 230/28 kV, DESN at the Horner TS site to meet the load growth in the south west Toronto area.
- Richview to Manby Corridor Reinforcement (R X K) Project (2023)– Adding a third double-circuit line between Richview TS and Manby TS, aimed to increase the transmission line capacity between the two stations to meet forecast load demand in the South West GTA.
- Multiple Station Refurbishment Projects – Work is also under way on refurbishing Bridgman TS, Fairbank TS, Main TS and Runnymede TS DESN#1. These projects are expected to be completed between 2021 and 2024.

5 LOAD FORECAST AND STUDY ASSUMPTIONS

5.1 Load Forecast

The electricity demand in the Toronto Region is anticipated to grow at an average rate of 0.9% over the next ten years. Figure 5-1 shows the Toronto Region’s summer peak load forecast developed during the Toronto IRRP process. This IRRP forecast was used to determine the loading that would be seen by transmission lines and autotransformer stations and to identify the need for additional line and auto-transformation capacity. Figure 4-1 also shows the Toronto region’s non-coincident load forecast developed using the individual station’s peak loads and which was used to determine the need for station capacity.

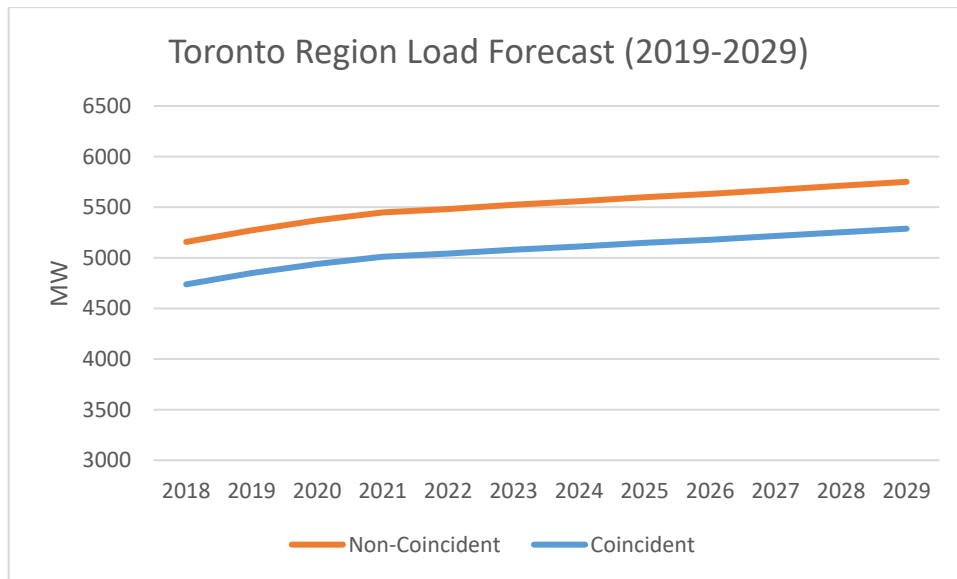

Figure 5-1: Toronto Region Load Forecast

The IRRP forecast shows that the Region peak summer load increases from 4850 MW in 2019 to 5290 MW by 2029. The corresponding non-coincident summer peak loads increase from 5270 MW to about 5750 MW over the same period. The IRRP and non-coincident load forecasts for the individual stations in the Toronto Region is given in Appendix D, Table D-1 and Table D-2.

The IRRP had provide an estimated of the energy-efficiency savings resulting from building codes and equipment standards improvement in Ontario. This has the potential to lower the demand growth in the region to approximately 0.6% annually. Details for the individual stations peak loads considering the energy-efficiency are given in Appendix D, Table D-3 and Table D-4.

5.2 Study Assumptions

The following other assumptions are made in this report.

- The study period for the RIP assessments is 2019-2029.
- All facilities that are identified in Section 4 and that are planned to be placed in-service within the study period are assumed to be in-service.

- Summer is the critical period with respect to line and transformer loadings. The assessment is therefore based on summer peak loads.
- Station capacity adequacy is assessed by comparing the non-coincident peak load with the station's normal planning supply capacity, assuming a 90% lagging power factor for stations having no low-voltage capacitor banks and 95% lagging power factor for stations having low voltage capacitor banks. Normal planning supply capacity for transformer stations is determined by the summer 10-day Limited Time Rating (LTR).
- Line capacity adequacy is assessed by using coincident peak loads in the area.
- Adequacy assessment is conducted as per Ontario Resource Transmission Assessment Criteria (ORTAC).
- Metrolinx plans to connect three Traction Power Substation (TPSS) to Hydro One's 230 kV circuits in Toronto area for GO Transit electrification – Mimico TPSS to K21C and K23C close to Manby TS; City View TPSS to V73R and V77R north of Richview TS; and Scarborough TPSS to C2L and C14L at Scarboro TS. Metrolinx have advised that their current electrification schedule is uncertain and new facilities would be built likely beyond 2023. Appendix F of the 2019 Toronto IRRP ("Richview TS x Manby TS Study") verified that the reinforcement of Richview TS to Manby TS Transmission Corridor is required by 2021 and that Metrolinx new load do not affect the need and timing of the project. After the completion of Richview TS to Manby TS Transmission Reinforcement, the new TPSS loads can be connected without need of any new facilities.

6 ADEQUACY OF EXISTING FACILITIES

THIS SECTION REVIEWS THE ADEQUACY OF THE EXISTING TRANSMISSION AND TRANSFORMER STATION FACILITIES SUPPLYING THE TORONTO REGION OVER THE PLANNING PERIOD (2019-2039). ALL PROJECTS CURRENTLY UNDERWAY ARE ASSUMED IN-SERVICE.

Within the current regional planning cycle two regional assessments have been conducted for the Toronto Region. The findings of these studies are input to this Regional Infrastructure Plan. The studies are:

- 2017 Toronto Region Needs Assessment (“NA”) Report
- 2019 Toronto Integrated Regional Resource Plan (“IRRP”) and Appendices

This section provides a review of the adequacy of the transmission lines and stations in the Metro Toronto Region. The adequacy is assessed using the latest regional load forecast provided in Appendix D from a loading perspective. Sustainment aspects were identified in the NA report and are addressed in Section 7 of this report. The review assumes that the following projects shown in Table 6-1 are in-service. Sections 6.1 to 6.4 present the results of this review.

Table 6-1: New Facilities Assumed In-Service

Facility	In-Service Date
Second DESN at Horner TS	2022
Richview to Manby 230 kV Corridor Reinforcement	2023
Copeland MTS Phase 2	2024

6.1 230 kV Transmission Facilities

The Metro Toronto 230 kV transmission facilities consist of the following 230 kV transmission circuits (please refer to Figure 3-1):

- a) Cherrywood TS to Leaside TS 230 kV circuits: C2L, C3L, C14L, C15L, C16L, and C17L
- b) Cherrywood TS to Agincourt TS 230 kV circuit C10A
- c) Cherrywood TS to Richview TS 230 kV circuits: C4R, C5R, C18R, and C20R
- d) Parkway TS to Richview TS 230 kV circuits: P21R and P22R
- e) Claireville TS to Richview TS 230 kV circuits: V73R, V74R, V75R, V76R, V77R, and V79R
- f) Richview TS to Manby TS 230 kV circuits: R1K, R2K, R13K, and R15K

The Cherrywood TS to Richview TS circuits, the Parkway TS to Richview TS circuits, and the Claireville TS to Richview TS circuits carry bulk transmission flows as well as serve local area station loads within the Sub-Region. These circuits are adequate² over the study period.

The Cherrywood TS to Agincourt TS circuit C10A is a radial circuit that supplies Agincourt TS and Cavanagh MTS. The circuit is adequate over the study period.

The Cherrywood TS to Leaside TS 230 kV circuits supply the Leaside TS 230/115 kV autotransformers as well as serve local area load. These circuits are adequate over the study period.

The Richview TS to Manby TS circuits supply the Manby TS 230/115 kV autotransformer station as well as Horner TS. With the Richview to Manby 230 kV Corridor Reinforcement in-service in 2023, the circuits will be adequate over the study period.

6.2 230/115 kV Autotransformers Facilities

The autotransformers at Manby TS and Leaside TS serve the 115 kV transmission network and local loads in Central Toronto. A 550 MW generation facility Portlands Energy Centre (“PEC”) is situated in Central Toronto, connecting to the 115 kV transmission system at Hearn Switching Station (“SS”).

The 230/115 kV autotransformers facilities in the region consist of the following elements:

- a. Manby East TS 230/115 kV autotransformers: T7, T8, T9
- b. Manby West TS 230/115 kV autotransformers: T1, T2, T12
- c. Leaside TS 230/115 kV autotransformers: T11, T12, T14, T15, T16, T17

Manby East and West TS autos supply two distinct 115 kV load pockets. Manby East TS autos supply Runnymede TS, Fairbank TS, and Wiltshire TS through the Manby TS to Wiltshire TS circuits. Manby West TS autos normally supply the Strachan TS, John TS, and Copeland MTS through Manby TS to John TS circuits. The Manby TS autotransformer facilities are adequate over the study period.

Leaside TS autos supply the rest of the 115kV transformer stations – Basin TS, Bridgman TS, Carlaw TS, Cecil TS, Charles TS, Dufferin TS, Duplex TS, Esplanade TS, Gerrard TS, Glengrove TS, Main TS, and Terauley TS. The Leaside TS autotransformer facilities are adequate over the study period.

6.3 115 kV Transmission Facilities

The 115 kV transmission facilities in the Metro Toronto Region serve local station loads in the Central Toronto area and are connected to the rest of the grid via Manby TS and Leaside TS autotransformers. The 115 kV transmission facilities can be divided into nine main corridors summarized below.

- a. Manby East TS x Wiltshire TS – Four circuits K1W, K3W, K11W, and K12W

² Adequate – means that current flows are with conductor or equipment thermal limits and all area bus voltages meet the Ontario Resource and Transmission Assessment Criteria (ORTAC) under normal and contingency conditions.

- b. Manby West TS x John TS – Six circuits H2JK, K6J, K13J, K14J, D11J, and D12J
- c. Leaside TS x Cecil TS – Three circuits L4C, L9C, and L12C
- d. Leaside TS x Hearn SS – Six circuits H6LC, H8LC, H1L, H3L, H7L, and H11L
- e. Leaside TS x Wiltshire TS – Four circuits L13W, L14W, L15, and L18W
- f. Leaside TS x Duplex TS and Glengrove TS – Four circuits L5D, L16D, L2Y, and D6Y
- g. Cecil TS x Esplanade TS – Two circuits C5E and C7E
- h. John TS x Esplanade TS x Hearn SS – Three circuits H2JK, H9DE/D11J, and H10DE/D12J

The Manby East TS to Wiltshire TS 115 kV circuits supply Runnymede TS, Fairbank TS, and Wiltshire TS and were identified as requiring reinforcement in the 2016 Metro Toronto RIP. This work was completed in November 2018. With the completion of this work, the corridor circuits are adequate over the study period.

The Manby West TS to John TS 115 kV circuits supply Strachan TS, John TS and Copeland MTS. The corridor circuits are adequate over the study period.

The Leaside TS to Cecil TS 115 kV circuits and the Leaside TS to Hearn SS 115 kV circuits supply Basin TS, Carlaw TS, Cecil TS, Charles TS, Gerrard TS, and Main TS. The circuits are adequate over the study period.

The Leaside TS to Wiltshire TS corridor supply Bridgman TS and Dufferin TS. It has been recently reinforced with the addition of the L18W circuit in 2016 (Midtown transmission reinforcement). With the completion of this work the existing corridor circuits are adequate over the study period.

The Leaside TS to Duplex TS and Glengrove TS circuits (L5D, L16D, L2Y, and D6Y) are radial circuits that supply loads at Duplex TS and Glengrove TS. The circuits are adequate over the study period.

The Cecil TS to Esplanade TS circuits supply Terauley TS. The circuits are adequate over the study period.

The John TS to Esplanade TS and Hearn SS supply Esplanade TS. The circuits are adequate over the study period.

6.4 Step-Down Transformer Station Facilities

There are a total of 35 step-down transformers stations in the Toronto Region, connected to the 230 kV and 115 kV transmission network as listed below. The stations summer peak load forecast are given in Appendix D Table D-1.

Table 6-2: Toronto Step-Down Transformer Stations

230 kV Connected		115 kV Connected		
Agincourt TS	Leslie TS	Basin TS	Esplanade TS	Fairbank TS
Bathurst TS	Malvern TS	Bridgman TS	Gerrard TS	Copeland MTS
Bermondsey TS	Rexdale TS	Carlaw TS	Glengrove TS	John TS
Cavanagh MTS	Scarboro TS	Cecil TS	Main TS	Strachan TS
Ellesmere TS	Sheppard TS	Charles TS	Terauley TS	Horner TS
Fairchild TS	Warden TS	Dufferin TS	Wiltshire TS	Manby TS
Finch TS	Richview TS	Duplex TS	Runnymede TS	
Leaside TS				

With the construction of the second DESN at Runnymede TS (completed in 2018) and the second DESN at Horner TS (planned to be in-service by 2022), there will be adequate transformer station capacity over the study period.

6.5 Longer Term Outlook (2030-2040)

While the RIP was focused on the 2019-2029 period, the Study Team has also looked at longer-term loading between 2030 and 2040. The results indicate that the following facilities may be overloaded or reach capacity over this period.

- Manby West TS 230/115 kV autotransformers, which is limited by the lowest rated unit T12 in the fleet. T12 autotransformer replacement, planned to be completed by 2025, is expected to relieve this constraint.
- Leaside TS 230/115 kV autotransformers. This capacity need is based on the assumption that two of the three units at Portlands Energy Centre GS are out-of-service, and total plant generation is 160 MW. Post-contingency control action is currently available to resolve this issue by transferring Dufferin TS to Manby supply. Refer to Appendix D of 2019 Toronto IRRP (“Planning Study Results”) for more details.
- Table 6.3 and 6.4 provide the adequacy summary of the transmission circuits and transformer stations potentially requiring relief within the 2030-2040 period.

Table 6-3: Longer Term Adequacy of Transmission Facilities

Facilities	Area MW Load ⁽¹⁾			MW Load Meeting Capability	Limiting Element	Limiting Contingency	Need Date
	2030	2035	2040				
115 kV Leaside TS x Wiltshire TS corridor	309	332	342	340	L15	L14W	2035-2040
115 kV Manby W TS x Riverside Jct. corridor	487	517	547	510	K13J	H2JK	2030-2035

(1) The sum of station’s coincident summer peak load adjusted for extreme weather, excluding energy-efficiency savings, assuming normal supply configuration, without load transfer

Table 6-4: Longer Term Adequacy of Step-Down Transformer Stations

Facilities	Station MW Load ⁽¹⁾			Station Limited Time Rating (LTR) MW	Need Date
	2030	2035	2040		
Fairbank TS	182	188	193	182	2030-2035
Sheppard TS	203	216	224	204	2030-2035
Strachan TS	167	182	193	169	2030-2035
Basin TS	85	91	95	88	2030-2035

(1) Station's non-coincident summer peak load, adjusted for extreme weather, excluding energy-efficiency savings

7 REGIONAL NEEDS AND PLANS

THIS SECTION DISCUSSES ELECTRICAL INFRASTRUCTURE NEEDS IN THE TORONTO REGION AND SUMMARIZES THE PLANS DEVELOPED TO ADDRESS THESE NEEDS.

This section outlines and discusses electrical infrastructure needs in the Toronto Region and plans to address these needs. The electrical infrastructure needs in the Toronto Region are summarized below in Table 7.1 and Table 7.2. Except for the Richview to Manby Reinforcement, these needs are primarily associated with the replacement of end-of-life equipment.

Table 7-1: Identified Near and Mid-Term Needs in Toronto Region

Section	Facilities	Need	Timing
7.1	Main TS	End-of-life of transformers T3 and T4	2021
7.2	H1L/H3L/H6LC/H8LC	End-of-life of overhead line section between Leaside 34 Jct. & Bloor St. Jct.	2023
7.3	L9C/L12C	End-of-life of overhead line section between Leaside TS & Balfour Jct.	2023
7.4	C5E/C7E	End-of-life underground cables between Esplanade TS & Terauley TS	2024
7.5	Richview TS to Manby TS 230 kV Corridor	Additional load meeting capability upstream of Manby TS (Richview TS to Manby TS 230 kV corridor)	2023
7.6	Manby TS	End-of-life of autotransformers T7, T9, T12, step-down transformer T13, and the 230 kV switchyard at Manby TS	2025
7.7	Bermondsey TS	End-of-life of transformers T3, T4 at Bermondsey TS	2025
7.8	John TS	End-of-life of T1, T2, T3, T4, T5, T6 transformers, 115 kV breakers, and LV switchgear at John TS	2026

Table 7-2: Identified Long-Term Needs in Toronto Region

Section	Facilities	Need	Timing
7.9.1	Fairbank TS	Station capacity exceeded	2030-2035
7.9.2	Sheppard TS	Station capacity exceeded	2030-2035
7.9.3	Strachan TS	Station capacity exceeded	2030-2035
7.9.4	Basin TS	Station capacity exceeded	2030-2035
7.9.5	115 kV Manby W TS x Riverside Jct. corridor	Manby TS x Riverside Jct section of circuit K13J overloaded for circuit H2JK contingency	2030-2035
7.9.6	Manby W TS Autotransformers	Autotransformer T12 overloaded for T1 or T2 contingency	2030-2035
7.9.7	115 kV Leaside TS x Wiltshire TS corridor	Leaside TS to Balfour Jct. section of circuit L15 overloaded for circuit L14W contingency	2035-2040
7.9.8	Leaside TS Autotransformers	Autotransformer T16 overloaded for circuit C15L or C17L contingency, assuming 160 MW at Portlands GS	2035-2040

7.1 Main TS: End-of-Life Transformers

7.1.1 Description

Main TS is a 115/13.8 kV transformer station serving the eastern part of Central Toronto including the Beaches and Danforth area. The station is electrically situated within the Leaside 115 kV zone, supplied via 115 kV circuits H7L/H11L (see Figure 7-1). Peak demand at Main TS has been on average 59 MW over the last 3 years and is expected to increase to 62 MW over the next 10 years.



Figure 7-1: Main TS

The two transformers at Main TS (T3 and T4) are 46-51 years old 75 MVA units and are reaching their end-of-life. In addition, other equipment in the station, such as 115 kV line disconnect switches, current and voltage transformers, are also reaching their end-of-life.

7.1.2 Alternatives and Recommendation

The following alternatives were considered to address Main TS end-of-life assets need:

1. **Alternative 1 - Maintain Status Quo:** This alternative was considered and rejected as it does not address the risk of failure due to asset condition and would result in increased maintenance expenses and will not meet Hydro One’s obligation to provide reliable supply to the customers.
2. **Alternative 2 - Replace with similar type and size equipment as per current standard:** Under this alternative the existing transformers at Main TS are replaced with new 115/13.8 kV transformers. This alternative would address the end-of-life assets need and would maintain reliable supply to the customers in the area.
3. **Alternative 3 - Converting Main TS to 230 kV operation:** This alternative would require replacing the existing transformers with new 230/13.8kV transformers and building a new 230kV supply to Main TS from either Warden TS or Leaside TS. The existing H7L/H11L circuits cannot be used as they are required for Hearn TS x Leaside TS use. This alternative is significantly more costly (3-4 times) compared to Option 2 as it would require building the new 230 kV supply in addition to replacing the transformers. It was therefore not considered further.
4. **Alternative 4 - Supplying Main TS switchgear from new transformers at Warden TS:** Under this alternative instead of replacing the existing aging transformers at Main TS, new 230/13.8 kV transformers will be installed at Warden TS, a 230/27.6 kV transformer station located approximately 4.5 km north-east of Main TS. This alternative is significantly more (3-4 times) costly compared to Option 2 due to the excessive amount of distribution cables required to connect the transformers at Warden TS to the switchgear at Main TS. It was therefore not considered further.

The Study Team recommends Alternative 2 as the technically preferred and most cost-effective alternative to refurbish Main TS. Further given the longer term potential for growth; need to provide system resiliency and flexibility; and insignificant incremental cost difference between 45/75 MVA and 60/100 MVA transformers, the Study Team recommends that Hydro One replace the existing transformers with larger 60/100 MVA units. The plan cost is estimated to be about \$33 million, and is expected to in-service by end 2021.

7.2 H1L/H3L/H6LC/H8LC: End-of-Life Overhead Section (Leaside 34 Jct. to Bloor St. Jct.)

7.2.1 Description

The 115 kV circuits H1L/H3L/H6LC/H8LC provide connections between Leaside TS, Hearn SS, and Cecil TS, and supply transformer stations in the eastern part of central Toronto including Gerrard TS, Carlaw TS, and Basin TS. Based on their asset condition, conductors along the overhead section between Leaside 34 Jct. and Bloor St. Jct. are determined to be approaching their end-of-life. Figure 7.2 shows the location of the end-of-life section.



Figure 7-2: H1L/H3L/H6LC/H8LC Section between Leaside 34 Jct. and Bloor St. Jct.

7.2.2 Alternatives and Recommendation

The following alternatives were considered to address the end-of-life assets need:

1. **Alternative 1 - Maintain Status Quo:** This alternative is rejected as it does not address the risk of failure due to asset condition and would result in increased maintenance expenses and reduce supply reliability to the customers.
2. **Alternative 2 – Refurbish the end-of-life overhead section as per current standard:** Under this alternative the existing end-of-life overhead section will be refurbished and the conductor will be replaced with largest size possible while retaining existing tower structures. This alternative addresses the end-of-life assets need, minimizes losses and maintains reliable supply to the customers in the area.
3. **Alternative 3 –Replace and rebuild line for future 230 kV operation:** Under this alternative the line would be rebuilt to 230kV standards so as to be able for future 230kV operation. This alternative would be significantly more costly than Alternative 2 and with no plans to utilize the line at the higher operating voltage, was rejected and not considered further.

The Study Team recommends that Hydro One proceed with Alternative 2 – the refurbishment of the end-of-life overhead section. The line refurbishment work is expected to be complete by 2023.

7.3 L9C/L12C: End-of-Life Overhead Section (Leaside TS to Balfour Jct.)

7.3.1 Description

The overhead section of 115 kV double circuit line L9C/L12C between Leaside TS and Balfour Jct. is over 80 years old and has been determined to be approaching its end-of-life. Figure 7.3 shows the location of the end-of-life section.

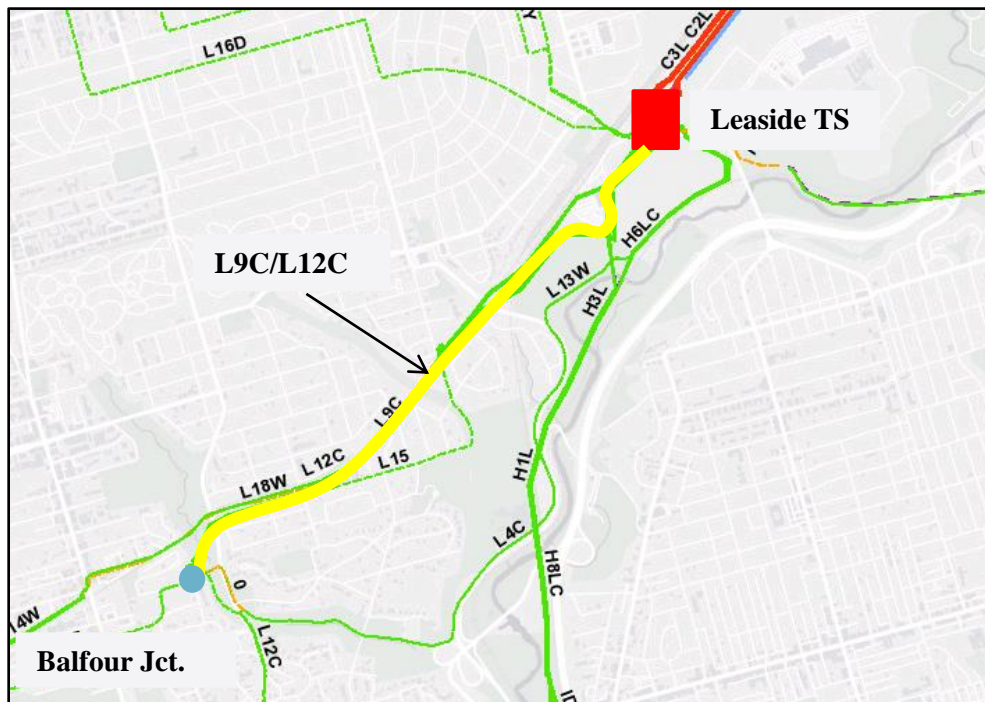

Figure 7-3: L9C/L12C Section between Leaside TS and Balfour Jct.

7.3.2 Alternatives and Recommendation

The following alternatives are considered to address the end-of-life assets need:

1. **Alternative 1 - Maintain Status Quo:** This alternative is rejected as it does not address the risk of failure due to asset condition and would result in increased maintenance expenses and reduce supply reliability to the customers.
2. **Alternative 2 – Refurbish the end-of-life overhead section as per current standard:** Refurbish the end-of-life overhead section and replace conductors with the largest size possible while retaining existing tower structures. This alternative is recommended as it addresses the end-of-life assets need and maintains reliable supply to the customers in the area.

The Study Team recommends that Hydro One proceed with Alternative 2 – the refurbishment of the end-of-life overhead section of L9C/L12C between Leaside TS and Balfour Jct. The line refurbishment work is planned to be completed by 2023.

7.4 C5E/C7E: End-of-Life Underground Cables (Esplanade TS to Terauley TS)

7.4.1 Description

Circuits C5E and C7E between Esplanade TS to Terauley TS are 115 kV paper insulated low pressure oil filled underground transmission cables that provide a critical 115 kV supply to Toronto’s downtown core and are partially routed along Lake Ontario.

These circuits, put into service in 1959, are among the oldest cable circuits in the Hydro One’s transmission system. Based on condition test results, the cable jackets and paper insulation were found to be in deteriorated condition which can lead to overheating, oil leaks, and cable failure. Figure 7.3 shows the location of the end-of-life section.

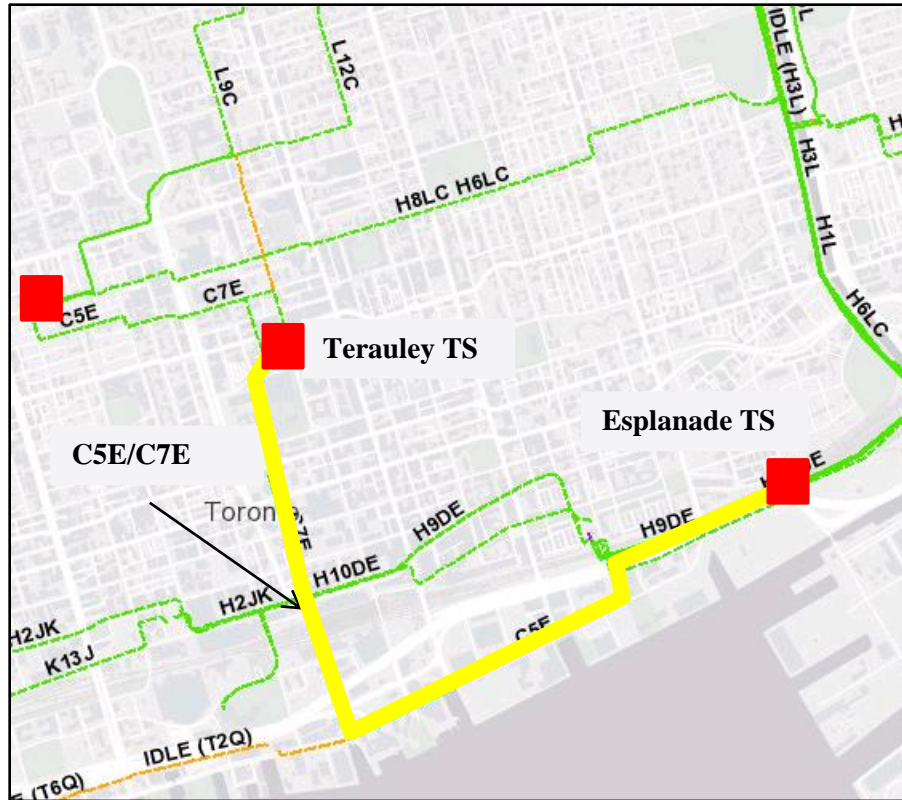

Figure 7-4: C5E/C7E Underground Cable Section between Esplanade TS and Terauley TS

7.4.2 Alternatives and Recommendation

The following alternatives were considered to address the end-of-life assets need:

1. **Alternative 1 - Maintain Status Quo:** This alternative is rejected as it does not address the risk of failure due to asset condition. Failure to these cables can impact the power supply to critical facilities in Downtown Toronto. A large oil leak would have significant environmental impact and require costly environmental remediation.
2. **Alternative 2 - Replace with similar type and size equipment as per current standard:** Under this alternative, the existing cables will be replaced with new 230 kV rated cables. The 230 kV rated cables have higher insulation and are less prone to failure. This alternative is recommended as it addresses the end-of-life assets need and maintains reliable supply to the customers in the area.

The Study Team recommends that Hydro One proceed with Alternative 2 – the replacement of the end-of-life underground cables between Esplanade TS and Terauley TS. Hydro One is currently proceeding with detailed estimation of options including tunneling for evaluating the most appropriate routes and construction options. This will be an input for public consultations to obtaining permit and necessary approvals along with environmental assessments. A final route and installation option will be selected as part of the open EA process. The cable refurbishment work is planned to be completed by 2024.

7.5 Richview TS to Manby TS 230 kV Corridor

7.5.1 Description

The 230 kV transmission corridor between Richview TS and Manby TS is the main supply path for the Western Sector of Central Toronto. Along this corridor there are two double-circuit 230 kV lines R1K/R2K and R13K/R15K. Together with circuit R24C between Richview TS and Cooksville TS, this corridor also supplies the load in the southern Mississauga and Oakville areas via Manby TS. The first cycle Metro Toronto Regional Infrastructure Plan has identified the need to increase transfer capability of this transmission corridor to support the continuous load growth in these areas.

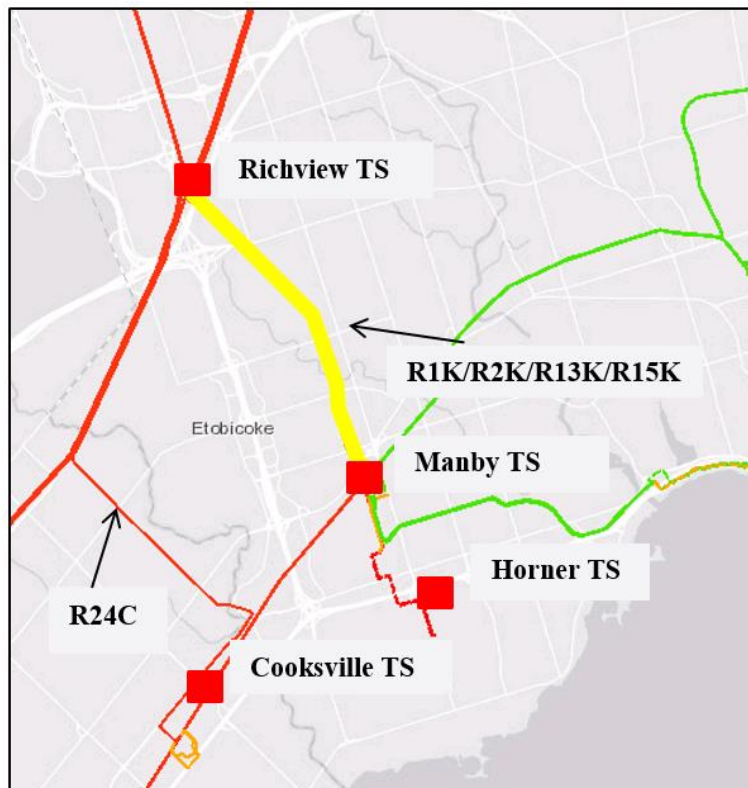

Figure 7-5: Richview TS to Manby TS 230 kV Corridor

7.5.2 Alternatives and Recommendation

A detailed assessment of the Richview TS to Manby TS corridor need was carried out in the Appendix F of the Toronto IRRP to reconfirm the capacity need of this corridor based on the changes in assumptions and the up-to-date load forecast. The assessment confirmed the need, and the Study Team continues to recommend that the reinforcement of the Richview TS to Manby TS 230 kV circuits to be completed as soon as possible.

Evaluation of alternatives was completed by the Study Team as documented in the 2015 Toronto Regional Infrastructure Plan. As per the Study Team's recommendation, Hydro One is proceeding with the Richview TS to Manby TS 230 kV transmission reinforcement project, which will be carried out in two phases:

- Phase 1:** This phase covers rebuilding the existing idle 115 kV overhead line on the transmission corridor between Richview TS and Manby TS to 230 kV standards. The new line will operate in parallel with the existing four 230 kV circuits from Richview TS to Manby TS, which will initially be reconfigured to create two “supercircuits.” This configuration avoids the need to build new terminations and new breakers at Manby TS. The IRRP noted the need for Phase 1 is in 2021 but the expected in-service is Q4 2023. Figure 7-6 below shows the transmission configuration after Phase 1 is completed.

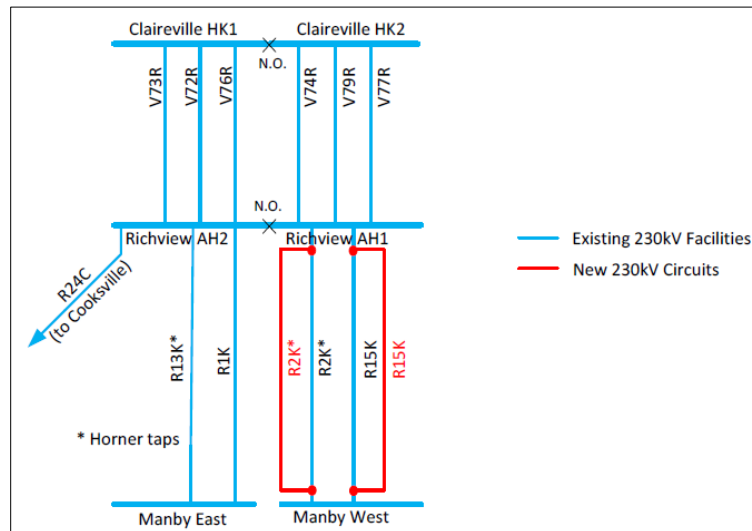

Figure 7-6: Richview TS to Manby TS 230 kV Corridor – Phase 1

- Phase 2:** In the second phase the super circuits will be unbundled with one new circuit connected to Manby West and one to Manby East with new termination installed at Manby TS. At Richview TS, the new circuits will be tapped to existing 230 kV circuits V73R and V79R from Claireville TS. This configuration allows Richview TS to be bypassed and permits continued supply to Manby TS should there be an emergency at Richview TS. The timing of Phase 2 will be planned to coincide with Manby TS end of life refurbishment, all of which is planned to be complete by 2025. Figure 7-7 below shows the transmission configuration after Phase 2 is completed. Note that the nomenclature shown for the new circuits are for illustrative purposes only and subject to change.

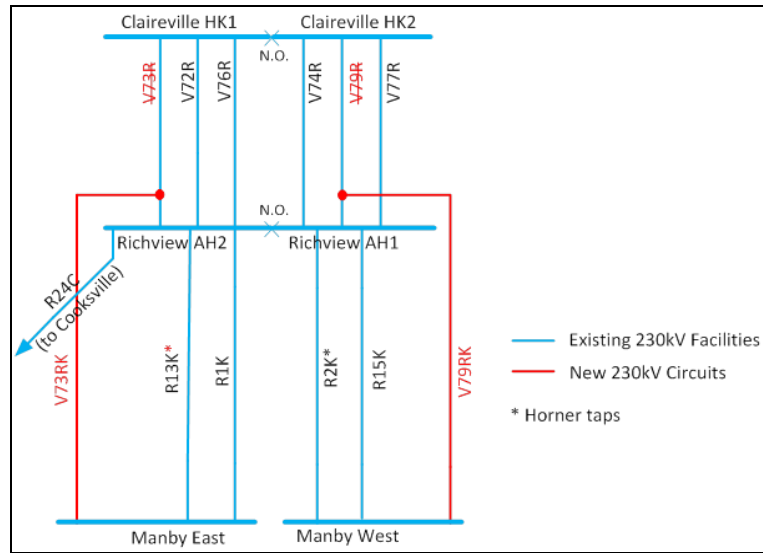

Figure 7-7: Richview TS to Manby TS 230 kV Corridor – Phase 2

7.6 Manby TS: End-of-Life Transformers and 230 kV Switchyard

7.6.1 Description

Manby TS is a major bulk electric switching and autotransformer station in the Toronto region. Station facilities include the Manby West and Manby East 230 kV and 115 kV switchyards, six 230/115 kV autotransformers (T1, T2, T7, T8, T9, T12), and six 230/27.6 kV step-down transformers supplying three DESNs (T3/T4, T5/T6, T13/T14).

The Manby TS autotransformers T7, T9, and T12 and step down transformer T13 are about 50 years old and all four have been identified to be nearing the end of their useful life and require replacement in the next 5 years. All three DESNs at Manby TS are currently at capacity, and the new second DESN at nearby Horner TS (I/S 2022) is expected to pick-up the load growth in the area.

The 230 kV oil breakers have also been identified to be nearing end-of-life and require replacement over the next 5-year period. As part of breaker replacement work, the 230 kV Manby West and Manby East switchyards will be modified and an additional three breakers added to terminate the two new circuits to Richview TS described above in Section 7.5 under Phase 2 for the Richview TS to Manby TS corridor reinforcement.



Figure 7-8: Manby TS

7.6.2 Alternatives and Recommendation

The following alternatives were considered to address the end-of-life assets need:

1. **Alternative 1 - Maintain Status Quo:** This alternative is rejected as it does not address the risk of failure due to asset condition and would result in increased maintenance expenses and reduce supply reliability for customers.
2. **Alternative 2 - Replace the end-of-life transformers with similar type and size equipment as per current standard, and rebuild/modify the 230 kV switchyard:** This alternative involves the replacement of Manby East T7, T9, and Manby West T12 autotransformers with 250 MVA units; Manby T13 DESN transformers with 75/93 MVA unit; replacement of end-of-life 230 kV oil breakers; as well as 230 kV switchyard modification and installing three new breakers to accommodate the new circuits to Richview TS (as part of the Richview TS to Manby TS Corridor Reinforcement). This alternative is recommended as it addresses the end-of-life asset needs and maintains reliable supply to customers in the area by:
 - reducing the risk of breaker failure events at Manby TS;
 - providing relief to the autotransformer capacity constraints in the long-term at Manby West TS by replacing the lowest rated unit T12; and
 - connecting the new circuits to Richview TS to support the continuous load growth in these areas.

The Study Team recommends that Hydro One proceed with Alternative 2 – the end-of-life transformer replacement and rebuilding of the Manby TS 230 kV switchyard. The project is expected to be completed by 2025.

7.7 Bermondsey TS: End-of-Life Transformers

7.7.1 Description

Bermondsey TS along with Ellesmere TS, Scarborough TS, Sheppard TS and Warden TS supply the Scarborough area and comprises of two DESNs. The T1/T2 DESN was built in 1990, has 6 feeders, an LTR

of 185.8 MW and supplied a summer 2018 peak load of 43 MW. The T3/T4 DESN was built in 1965, has 12 feeders, an LTR of 162.5 MW and supplied a 2018 summer peak load of 117 MW.

The T3 and T4 transformers are about 55 years old, have been identified as nearing the end of their useful life and requiring replacement in the next 5 years.

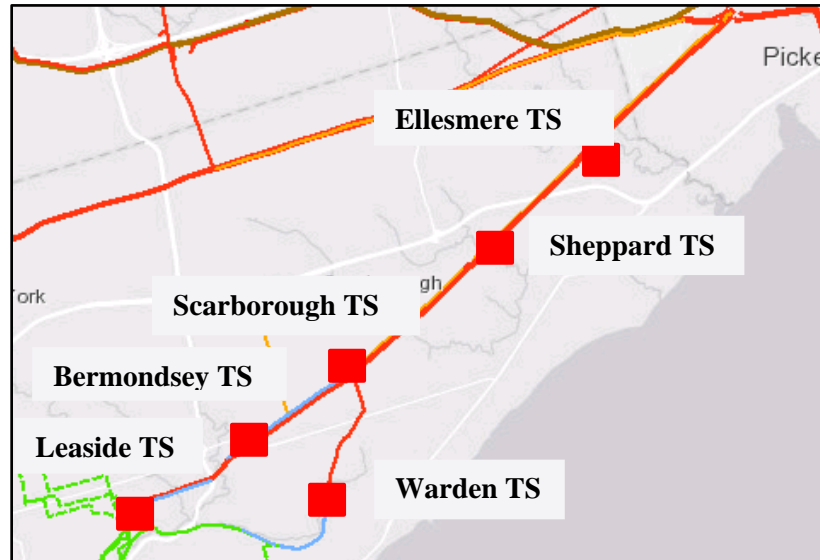

Figure 7-9: Bermondsey TS and Surrounding Stations

7.7.2 Alternatives and Recommendation

The recommendation for the end of life replacement is as follows:

1. **Alternative 1 - Maintain Status Quo:** This alternative is rejected as it does not address the risk of failure due to asset condition and would result in increased maintenance expenses and reduce supply reliability to the customers.
2. **Alternative 2 - Decommission the T3/T4 DESN at its end-of-life:** This alternative is not viable as there would be insufficient feeder capacity to supply the existing load. It was not considered further.
3. **Alternative 3 - Downsize (replace with smaller 83 MVA transformers):** This alternative would require extensive feeder transfers, and reconfiguration of the station including addition of new feeders on the T1/T2 DESN. The cost of the station reconfiguration work is expected to exceed \$5M and significantly exceeds the \$500-600k cost savings resulting from using the smaller size transformers.
4. **Alternative 4 - Replace with similar type and size equipment as per current standard:** This alternative is recommended as this is the most cost effective option, and addresses the end-of-life assets need and maintains reliable supply to the customers in the area.

Considering above options, the Study Team recommends that Hydro One proceed with Alternative 4 – the refurbishment of the T3/T4 DESN of Bermondsey TS and build to current standard. The refurbishment plan is expected to be in-service by 2025.

7.8 John TS: End-of-Life Transformers, 115 kV Breakers, and LV Switchgear

7.8.1 Description

John TS (also referred to as Windsor TS) is connected to the 115 kV Manby West system and supplies the western half of City of Toronto's downtown district. Station facilities include a 115 kV switchyard and six 115/13.8 kV step-down transformers (T1, T2, T3, T4, T5, T6) supplying six Toronto Hydro low voltage metalclad switchgears. The summer 10-day LTR is 311 MW. The station's 2018 actual non-coincident summer peak load (adjusted for extreme weather) was about 261 MW.

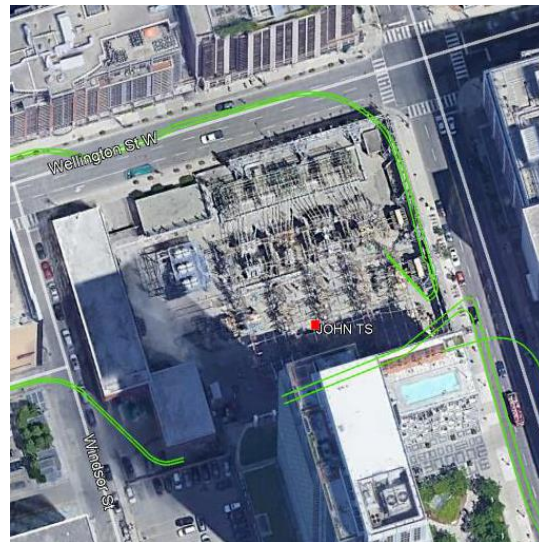

Figure 7-10: John TS

The T1 and T4 step-down transformers at John TS, both over 50 years old and in poor condition, were replaced in 2019. The step down transformers (T2, T3, T5 and T6) which range in age from 44-50 years are also at, or nearing, end of life. It is expected that these transformers will need to be replaced in the next 3-5 years. The 115 kV breakers are mostly oil type and are about 44 years old. They are also nearing end of useful life and are expected to require replacement in the next 5-10 years.

Toronto Hydro has also identified the need for renewal of their switchgear facilities at John TS. This work will be done over multiple phases and is expected to take 20-25 years to fully complete. The first phase involves relocating the feeders from switchgear at John TS to new switchgear at Copeland MTS so as to permit of the replacement of switchgear at John TS. The presence of Copeland MTS, which went into service in 2019, enables the switchgear replacement due to the capacity (transformation and feeder positions) at Copeland MTS that are not available at John TS or other neighboring stations. The load transfer to Copeland MTS is necessary to reduce load at John TS to facilitate the transformer and switchgear replacement work at John TS.

Toronto Hydro plan to initiate the switchgear renewal process starting with the Windsor Station A5-A6 and the A3-A4 metalclad switchgear buses. These buses are expected to be replaced by the new A19-A20 bus

in 2022-2023 and later followed by A21-A22 bus. Hydro One will replace associated low voltage transformer breaker disconnect switches and cables in coordination with Toronto Hydro.

7.8.2 Alternatives and Recommendation

The following alternatives were considered to address the end-of-life assets need:

1. **Alternative 1 - Maintain Status Quo:** This alternative is rejected as it does not address the risk of failure due to asset condition and would result in increased maintenance expenses and reduce supply reliability to the customers.
2. **Alternative 2 – Reducing the Number of Transformers from Six to Four Units:** As part of the John TS refurbishment work and the consequent reduction in loading at the station, Hydro One investigated the opportunity for reducing the number of 115/13.8 kV transformer units at John TS from the current six units to four units. Hydro One assessed with Toronto Hydro the feasibility of the following two options:
 - i. Reducing the number of switchgear pairs in the station from the current six to four to match the supply from four transformers. The assessment concluded that Copeland MTS has only enough feeder positions available to pick up one bus (typically 14-16 feeders) from John TS, and therefore there are no additional feeder positions available at Copeland MTS to further eliminate another bus at John TS. As such this option is not feasible.
 - ii. Reducing the number of transformer supply points to the existing six switchgear pairs through switchgear bus bundling (while not reducing the number of feeder positions at the station). This involved looking at opportunities of electrically joining presently distinct switchgear pairs while at the same time respecting equipment ratings. No opportunities were found that would respect equipment ratings. If opportunities that would respect equipment ratings had been found these would then be reviewed based upon operational factors involving customers impacted by a contingency, restoration times, etc. A first review of these operational factors found that Toronto Hydro's ability to perform bus load transfers would be limited than what it is today and its restoration times would be lengthened compared to what exists today due to the increased concentration of customers per bus. Given the lack of opportunities and the negative operational impacts even if opportunities were to be found, this option is not feasible.
 - iii. Consistent with the IRRP load forecast, Toronto Hydro has cited continued electricity demand along with higher reliability from customers for new connections to its distribution system in the downtown core. The growth in new connections coupled with Toronto Hydro's distribution system for reliable service is leading to the demand for feeder positions outpacing the peak demand growth. Six switchgear pairs along with six transformer supply points are still required for John/Windsor TS.

Based on the findings of above assessments, this alternative is not viable as Toronto Hydro feeder requirements are such that all of the six transformers are needed to supply load in the area via the six pairs of Toronto Hydro buses as described above.

3. **Alternative 3 - Similar Connection Arrangement with 60/100 MVA Transformers:** This alternative is recommended as it addresses the end-of-life assets need and maintains reliable supply

to the customers in the area. This alternative involves the replacement of the remaining T2, T3 (45/75 MVA), and T5, T6 (75/125 MVA) transformers with 60/100 MVA units, replacement of the LV switchgear in coordination with Toronto Hydro, and replacement of the existing oil filled breakers with SF6 breakers in the 115 kV switchyard. Minor modifications may be made (to the extent practically possible) to improve operational flexibility under outage conditions. Several options as described below were considered into the scope of the John TS refurbishment:

- i. Downsize (replace with smaller size transformers): The renewal of John TS switchgear facilities is expected to be completed over multiple phases within the next 20-25 years. Over this time period, the load of an existing switchgear will be transferred from one transformer winding pairs to another to connect to the new switchgear. Since some of the switchgear is heavily loaded, all of the transformer windings should be able to handle the maximum load of a single switchgear (i.e., 3000 Amps). For this reason, downsizing of John TS transformers is not viable.
- ii. Rebuild/reconfigure the 115 kV switchyard to a “Breaker-and-Half” configuration: The existing 115 kV breakers and buses are currently arranged in a ring-bus configuration and consideration was given to rebuilding and reconfiguring the 115 kV switchyard using a breaker and half arrangement. However, this alternative is not viable due to physical space constraints and clearances required for equipment and personnel safety. Although, practically constrained, this option will also require rerouting and retermination of high voltage cables and the cost of investment required for this reconfiguration significantly outweigh the incremental benefits.

The Study Team therefore recommends that Hydro One to proceed with Alternative 3 as described above. The John TS refurbishment plan is expected to be in service by 2026.

7.9 Long-Term Capacity Needs

A number of longer term capacity needs have been identified as described in Section 6.5 and Table 7.2. The Study team recommends that these needs be monitored and evaluated in future planning cycles. No investment is required at this time due to the forecast uncertainty and the longer-term timing of need. Preliminary comments are given below.

7.9.1 Fairbank TS Capacity Need

Fairbank TS load is expected to exceed LTR within the 2030-2035 time period. Consideration may be given to load transfer to the neighboring Runnymede TS. The Study Team recommends reviewing the loading in the next planning cycle.

7.9.2 Sheppard TS Capacity Need

Sheppard TS is also forecast to exceed capacity within the 2030-2035 time period. Consideration may be given to utilizing the idle winding on transformers T1/T2. The Study Team recommends reviewing the loading in the next planning cycle.

7.9.3 Strachan TS Capacity Need

Strachan TS is forecast to exceed capacity within the 2030-2035 time period. Consideration may be given to provide relief to Strachan TS through permanent load transfers to Copeland MTS and/or John TS. The Study Team recommends reviewing the loading in the next planning cycle.

7.9.4 Basin TS Capacity Need

Basin TS is located in the Portlands area in Downtown Toronto. The need for additional capacity at Basin TS is expected to arise in the long-term (within the 2030-2035 time period). The timing of the need is dependent on the pace of development in the area. Physical space is available at the current Basin TS site to plan and build a second DESN to meet long term needs.

The City of Toronto is planning the re-development of the Portlands. The area may see additional load beyond that which has been included in the present forecasts. The timing of any new needs will depend upon the timing of the City's plan.

However, the City's current re-development plans will end the continued operation of Basin TS and several high voltage lines in their current locations in the Portlands. This will significantly impact both Hydro One infrastructure and Toronto Hydro infrastructure within and outside of Basin TS. No sites for a replacement transformer station or high voltage line routes have been identified by the City.

Hydro One and Toronto Hydro have requested the City to revise its plans so as to avoid the conflicts with Basin TS and high voltage lines. Hydro One and Toronto Hydro have also joined others in a legal appeal of the City's land plans.

Given the appeal and lack of information currently available to Hydro One and Toronto Hydro from the City, the Study Team recommends that Hydro One and Toronto Hydro continue to monitor the situation and update the Study Team as appropriate. Plans for supplying the Portlands area will be developed as more information becomes known.

7.9.5 Manby West TS to Riverside Jct. Corridor Capacity Need

The Manby TS x Riverside Jct. section of K13J/K14J is potentially overloaded under certain contingency conditions within the 2030-2035 time period. Consideration may be given to reconductor circuit with a higher ampacity conductor. The Study Team recommends reviewing the loading in the next planning cycle.

7.9.6 Manby West TS Autotransformers T12 Capacity Need

Manby West TS 230/115 kV autotransformers is restricted by the lowest rated unit T12 in the fleet, and is potentially overloaded within the 2030-2035 time period, following T1 or T2 contingency. T12 autotransformer replacement, planned to be completed by 2025, is expected to provide relieve to this constraint and meet the capacity requirement at Manby West TS autotransformers facility. See Section 7.5 for more details.

7.9.7 Leaside TS to Wiltshire TS Corridor Capacity Need

The Leaside TS x Balfour Jct. section of the underground 115 kV circuit L15, connecting Leaside TS and Wiltshire TS, is potentially overloaded in the long-term within the 2035-2040 time period. The Study Team determines that no further investment is required to address this need at this time due to the level of uncertainties and amount of lead time available. This need will be reevaluated in the next planning cycle.

7.9.8 Leaside TS Autotransformers T16 Capacity Need

Leaside TS autotransformer T16 is potentially overloaded in the long-term within the 2035-2040 time period, following circuit C15L or C17L contingency, assuming that two of the three units at Portlands Energy Centre GS are out-of-service, and total plant generation is 160 MW. Post-contingency control action is currently available to resolve this issue by transferring Dufferin TS to Manby supply. The Study Team determines that no further investment is required to address this need at this time due to the level of forecast uncertainty and amount of lead time available. The Study Team recommends reviewing the loading in the next planning cycle.

8 CONCLUSIONS AND NEXT STEPS

THIS REGIONAL INFRASTRUCTURE PLAN CONCLUDES THE REGIONAL PLANNING PROCESS FOR THE TORONTO REGION.

The major infrastructure investments recommended by the Study Team in the near and mid-term planning horizon are provided in Table 8-1 below, along with their planned in-service date and budgetary estimates for planning purpose.

Table 8-1: Recommended Plans in Toronto Region over the Next 10 Years

No.	Need	Recommended Action Plan	Planned I/S Date	Budgetary Estimate ⁽¹⁾
1	Main TS: End-of-life of transformers T3/T4	Replace the end-of-life transformers with similar type and size equipment as per current standard	2021	\$33M
2	H1L/H3L/H6LC/H8LC: End-of-life of Leaside Jct. to Bloor St. Jct. overhead section	Refurbish the end-of-life H1L/H3L/H6LC/H8LC section	2023	\$11M
3	L9C/L12C: End-of-life of Leaside TS to Balfour Jct. overhead section	Refurbish the end-of-life L9C/L12C section	2023	\$3M
4	C5E/C7E: End-of-life of underground cables between Esplanade TS and Terauley TS	Replace the end-of-life C5E/C7E cables	2024	\$128M
5	Richview TS to Manby TS 230 kV Corridor Reinforcement	Replace existing idle 115 kV double circuit line with new 230 kV double circuit line between Richview TS and Manby TS	2023	\$21M
6	Manby TS: End-of-life of autotransformers (T7, T9, T12), step-down transformer (T13), and the 230 kV switchyard	Replace the end-of-life transformers with similar type and size equipment as per current standard, and refurbish/reconfigure Manby 230 kV switchyard	2025	\$85M
7	Bermondsey TS: End-of-life of transformers T3/T4	Replace the end-of-life transformers with similar type and size equipment as per current standard	2025	\$27M
8	John TS: End-of-life of transformers (T1, T2, T3, T4, T5, T6), 115 kV breakers, and LV switchgear	Replace with similar type and size equipment as per current standard	2026	\$102M

(1) Budgetary estimates are provided for Hydro One's portion of the work

The Study Team recommends that:

- Hydro One to continue with the implementation of infrastructure investments listed in Table 8-1 while keeping the Study Team apprised of project status;
- All the other identified needs/options in the long-term will be further reviewed by the Study Team in the next regional planning cycle.

9 REFERENCES

- [1] **Metro Toronto Regional Infrastructure Plan (2016)**
<https://www.hydroone.com/abouthydroone/CorporateInformation/regionalplans/metrotoronto/Documents/RIP%20Report%20Metro%20Toronto.pdf>

- [2] **Toronto Region Needs Assessment (2017)**
<https://www.hydroone.com/abouthydroone/CorporateInformation/regionalplans/metrotoronto/Documents/Needs%20Assessment%20-%20Toronto%20Region%20-%20Final.pdf>

- [3] **Toronto Region Scoping Assessment (2018)**
<http://www.ieso.ca/-/media/Files/IESO/Document-Library/regional-planning/Toronto/Toronto-Scoping-Assessment-Outcome-Report-February-2018.pdf?la=en>

- [4] **Toronto Integrated Regional Resource Plan (2019)**
<http://www.ieso.ca/-/media/Files/IESO/Document-Library/regional-planning/Toronto/engagement/Toronto-IRRP-20190809-Report.pdf?la=en>

- [5] **Toronto Integrated Regional Resource Plan - Appendices (2019)**
<http://www.ieso.ca/-/media/Files/IESO/Document-Library/regional-planning/Toronto/engagement/Toronto-IRRP-Appendices.pdf?la=en>

APPENDIX A. STATIONS IN THE TORONTO REGION

Station (DESN)	Voltage (kV)	Supply Circuits
Agincourt TS T5/T6	230/27.6	C4R/C10A
Basin TS T3/T5	115/13.8	H3L/H1L
Bathurst TS T1/T2	230/27.6	P22R/C18R
Bathurst TS T3/T4	230/27.6	P22R/C18R
Bermondsey TS T1/T2	230/27.6	C17L/C14L
Bermondsey TS T3/T4	230/27.6	C17L/C14L
Bridgman TS T11/T12/T13/T14/T15	115/13.8	L13W/L15/L14W
Carlaw TS T1/T2	115/13.8	H1L/H3L
Cecil TS T1/T2	115/13.8	Cecil Buses H & P
Cecil TS T3/T4	115/13.8	Cecil Buses P & H
Charles TS T1/T2	115/13.8	L4C/L9C
Charles TS T3/T4	115/13.8	L12C/L4C
Dufferin TS T1/T3	115/13.8	L13W/L15
Dufferin TS T2/T4	115/13.8	L13W/L15
Duplex TS T1/T2	115/13.8	L16D/L5D
Duplex TS T3/T4	115/13.8	L5D/L16D
Ellesmere TS T3/T4	230/27.6	C2L/C3L
Esplanade TS T11/T12/T13	115/13.8	H2JK/H10EJ(C5E)/H9EJ(C7E)
Fairbank TS T1/T3	115/27.6	K3W/K1W
Fairbank TS T2/T4	115/27.6	K3W/K1W
Fairchild TS T1/T2	230/27.6	C18R/C20R
Fairchild TS T3/T4	230/27.6	C18R/C20R

Station (DESN)	Voltage (kV)	Supply Circuits
Finch TS T1/T2	230/27.6	C20R/P22R
Finch TS T3/T4	230/27.6	P21R/C4R
Gerrard TS T1/T3/T4	115/13.8	H3L/H1L
Glengrove TS T1/T3	115/13.8	D6Y/L2Y
Glengrove TS T2/T4	115/13.8	D6Y/L2Y
Horner TS T3/T4	230/27.6	R13K/R2K
John TS T1/T2/T3/T4	115/13.8	John Buses K1 & K2 & K3 & K4
John TS T5/T6	115/13.8	John Buses K1 & K4
Leaside TS T19/T20/T21 13.8	230/13.8	C2L/C3L/C16L
Leaside TS T19/T20/T21 27.6	230/27.6	C2L/C3L/C16L
Leslie TS T1/T2 13.8	230/13.8	P21R/C5R
Leslie TS T1/T2 27.6	230/27.6	P21R/C5R
Leslie TS T3/T4	230/27.6	P21R/C5R
Main TS T3/T4	115/13.8	H7L/H11L
Malvern TS T3/T4	230/27.6	C4R/C5R
Manby TS T13/T14	230/27.6	Manby W Buses A1 & H1
Manby TS T3/T4	230/27.6	Manby W Buses A1 & H1
Manby TS T5/T6	230/27.6	Manby E Buses H2 & A2
Rexdale TS T1/T2	230/27.6	V74R/V76R
Richview TS T1/T2	230/27.6	Richview Buses H1 & A1
Richview TS T5/T6	230/27.6	V74R/V72R
Richview TS T7/T8	230/27.6	Richview Buses H2 & A2
Runnymede TS T3/T4	115/27.6	K12W/K11W

Station (DESN)	Voltage (kV)	Supply Circuits
Scarboro TS T21/T22	230/27.6	C14L/C2L
Scarboro TS T23/T24	230/27.6	C15L/C3L
Sheppard TS T1/T2	230/27.6	C16L/C15L
Sheppard TS T3/T4	230/27.6	C15L/C16L
Strachan TS T12/T14	115/13.8	H2JK/K6J
Strachan TS T13/T15	115/13.8	K6J/H2JK
Terauley TS T1/T4	115/13.8	C7E/C5E
Terauley TS T2/T3	115/13.8	C7E/C5E
Warden TS T3/T4	230/27.6	C14L/C17L
Wiltshire TS T1/T6	115/13.8	K1W/K3W (Wiltshire Buses H1 & H3)
Wiltshire TS T2/T5	115/13.8	K1W/K3W (Wiltshire Buses H1 & H3)
Wiltshire TS T3/T4	115/13.8	K1W/K3W (Wiltshire Buses H1 & H3)
Cavanagh MTS T1/T2	230/27.6	C20R/C10A
IBM Markham CTS T1/T2	230/13.8	P21R/P22R
Markham MTS #1 T1/T2	230/27.6	P21R/P22R
Copeland MTS T1/T3 (Future)	115/13.8	D11J/D12J

APPENDIX B. TRANSMISSION LINES IN THE TORONTO REGION

Location	Circuit Designations	Voltage (kV)
Richview x Manby	R1K, R2K, R13K, R15K	230
Richview x Cooksville	R24C	230
Manby x Cooksville	K21C, K23C	230
Cherrywood x Leaside	C2L, C3L, C14L, C15L, C16L, C17L	230
Cherrywood x Richview	C4R, C5R, C18R, C20R	230
Cherrywood x Agincourt	C10A	230
Parkway x Richview	P21R, P22R	230
Claireville x Richview	V72R, V73R, V74R, V76R, V77R, V79R	230
Manby East x Wiltshire	K1W, K3W, K11W, K12W	115
Manby West x John	K6J, K13J, K14J	115
Manby West x John x Hearn	H2JK	115
John x Esplanade x Hearn	D11J, D12J, H9DE, H10DE	115
Esplanade x Cecil	C5E, C7E	115
Hearn x Cecil x Leaside	H6LC, H8LC	115
Hearn x Leaside	H1L, H3L, H7L, H11L	115
Leaside x Bridgman x Wiltshire	L13W, L14W, L15, L18W	115
Leaside x Charles	L4C	115
Leaside x Cecil	L9C, L12C	115
Leaside x Duplex	L5D, L16D	115
Leaside x Glengrove	L2Y	115
Duplex x Glengrove	D6Y	115

APPENDIX C. DISTRIBUTORS IN THE TORONTO REGION

Distributor Name	Station Name	Connection Type
Toronto Hydro-Electric System Limited	Agincourt TS	Tx
	Basin TS	Tx
	Bathurst TS	Tx
	Bermondsey TS	Tx
	Bridgman TS	Tx
	Carlaw TS	Tx
	Cecil TS	Tx
	Charles TS	Tx
	Dufferin TS	Tx
	Duplex TS	Tx
	Ellesmere TS	Tx
	Esplanade TS	Tx
	Fairbank TS	Tx
	Fairchild TS	Tx
	Finch TS	Tx
	Gerrard TS	Tx
	Glengrove TS	Tx
	Horner TS	Tx
	John TS	Tx
	Leaside TS	Tx
	Leslie TS	Tx
	Main TS	Tx
	Malvern TS	Tx
	Manby TS	Tx
	Rexdale TS	Tx
	Richview TS	Tx
	Runnymede TS	Tx
	Scarboro TS	Tx
	Sheppard TS	Tx
	Strachan TS	Tx
	Terauley TS	Tx
Warden TS	Tx	
Wiltshire TS	Tx	
Cavanagh MTS	Tx	
Copeland MTS	Tx	

Distributor Name	Station Name	Connection Type
Hydro One Networks Inc. (Dx)	Agincourt TS	Tx
	Fairchild TS	Tx
	Finch TS	Tx
	Leslie TS	Tx
	Malvern TS	Tx
	Richview TS	Tx
	Sheppard TS	Tx
Alectra Utilities	Agincourt TS	Dx
	Fairchild TS	Dx
	Finch TS	Dx
	Leslie TS	Dx
	Richview TS	Dx
Elexicon Energy Inc.	Malvern TS	Dx
	Sheppard TS	Dx

APPENDIX D. TORONTO REGION LOAD FORECAST

Table D-1: Toronto IRRP Load Forecast, without the Impacts of Energy-Efficiency Savings

Area & Station	LTR (MW)	Near & Mid-Term Forecast												Long-Term Forecast		
		2018	2019	2020	2021	2022	2023	2024	2025	2026	2027	2028	2029	2030	2035	2040
North 230 kV																
Agincourt TS	174	92	95	98	100	101	102	103	104	104	105	106	106	107	110	114
Bathurst TS	334	210	220	226	229	231	233	235	236	238	239	242	245	247	265	274
Cavanagh MTS	157	91	92	93	94	95	95	95	96	97	98	98	99	100	108	112
Fairchild TS	346	235	237	239	241	243	245	247	249	250	250	252	254	255	260	265
Finch TS	365	249	254	258	260	261	262	263	265	267	269	271	272	273	279	284
Leslie TS	325	233	241	249	250	254	255	258	260	261	262	264	265	266	283	293
Malvern TS	176	83	84	85	86	86	86	87	88	88	91	93	95	96	103	106
East 230 kV																
Bermondsey TS	348	148	152	154	156	159	160	161	162	164	164	165	165	165	166	172
Ellesmere TS	189	124	126	128	129	130	131	131	132	133	133	134	134	134	135	138
Leaside TS	202	151	156	160	163	164	165	165	167	168	168	169	169	169	171	178
Scarboro TS	340	204	207	209	211	212	213	214	216	218	218	218	219	219	230	236
Sheppard TS	205	141	144	146	148	148	150	151	153	153	153	156	159	161	171	177
Warden TS	182	106	108	109	110	111	112	113	113	113	117	120	122	124	132	136
West 230 kV																
Horner TS	365	133	137	138	140	140	142	143	144	145	149	154	158	161	177	187
Manby TS	226	191	202	205	211	212	215	216	217	219	220	222	224	226	240	251
Rexdale TS	187	123	124	125	125	127	127	129	129	129	129	127	127	125	118	110
Richview TS	460	227	213	217	219	220	222	223	224	226	224	222	219	218	213	204
Leaside 115 kV																
Basin TS	88	65	71	75	76	77	77	78	79	79	81	83	84	85	91	95
Bridgman TS	212	154	154	156	157	157	160	161	161	162	163	164	165	167	180	186
Carlaw TS	73	66	67	67	67	68	68	69	69	70	70	70	70	72	72	72
Cecil TS	215	162	170	175	177	179	181	182	183	184	182	180	178	177	177	177
Charles TS	211	145	151	154	155	156	158	158	159	159	161	164	166	167	175	176
Dufferin TS	170	136	121	124	125	125	126	127	128	130	134	135	139	142	152	156
Duplex TS	128	99	101	100	98	97	94	94	96	97	98	99	100	102	108	113
Esplanade TS	187	162	142	145	146	146	148	148	149	150	149	147	146	143	147	148
Gerrard TS	102	35	44	47	49	49	50	50	50	51	51	51	51	51	52	53
Glengrove TS	88	48	50	50	51	51	51	51	51	51	52	54	55	56	60	62
Main TS	77	56	57	57	58	59	59	59	60	60	62	62	63	64	65	65
Terauley TS	249	175	188	194	190	188	188	191	191	191	190	187	185	184	181	182
Manby E 115 kV																
Fairbank TS	182	141	125	132	135	139	142	144	145	146	147	148	149	149	154	158
Runnymede TS	219	96	136	141	143	143	146	146	148	148	149	149	151	151	158	164
Wiltshire TS	133	55	71	72	72	72	73	73	73	75	75	76	76	76	83	86
Manby W 115 kV																
Copeland MTS	130	0	0	52	93	93	94	94	96	96	98	99	100	102	107	112
John TS	314	263	266	215	201	202	203	204	206	206	210	212	215	218	228	242
Strachan TS	169	139	143	145	146	147	147	149	149	150	155	159	163	167	182	193

Table D-2: Toronto Non-Coincident Load Forecast, without the Impacts of Energy-Efficiency Savings

Area & Station	LTR (MW)	Near & Mid-Term Forecast (MW)												Long-Term Forecast (MW)		
		2018 ⁽¹⁾	2019	2020	2021	2022	2023	2024	2025	2026	2027	2028	2029	2030	2035	2040
North 230 kV																
Agincourt TS	174	112	115	119	121	122	124	125	126	126	127	128	128	130	133	138
Bathurst TS	334	227	238	244	248	250	252	254	255	257	258	262	265	267	287	296
Cavanagh MTS	157	108	109	110	112	113	113	113	114	115	116	116	117	119	128	133
Fairchild TS	346	268	270	272	274	277	279	281	284	285	285	287	289	290	296	302
Finch TS	365	290	296	301	303	304	305	306	309	311	313	316	317	318	325	331
Leslie TS	325	233	241	249	250	254	255	258	260	261	262	264	265	266	283	293
Malvern TS	176	105	106	108	109	109	109	110	111	111	115	118	120	122	130	134
East 230 kV																
Bermondsey TS	348	160	164	166	169	171	173	173	175	177	177	178	178	178	179	186
Ellesmere TS	189	124	126	128	129	130	131	131	132	133	133	134	134	134	135	138
Leaside TS	202	163	169	174	177	178	179	179	181	182	182	183	183	183	186	194
Scarboro TS	340	222	225	227	229	231	232	233	235	237	237	237	238	238	250	257
Sheppard TS	205	178	182	184	187	187	189	191	193	193	193	197	201	203	216	224
Warden TS	182	123	125	126	127	129	130	131	131	131	135	139	141	144	153	157
West 230 kV																
Horner TS ⁽²⁾	365	141	145	146	148	193	199	202	204	208	213	221	228	234	268	292
Manby TS ⁽²⁾	226	245	258	262	269	225	225	225	225	225	225	225	225	225	225	225
Rexdale TS	187	136	138	139	139	141	141	143	143	143	143	141	141	139	131	122
Richview TS	460	279	263	268	270	271	274	275	276	279	276	274	270	269	263	252
Leaside 115 kV																
Basin TS	88	65	71	75	76	77	77	78	79	79	81	83	84	85	91	95
Bridgman TS	212	154	154	156	157	157	160	161	161	162	163	164	165	167	180	186
Carlaw TS	73	66	67	67	67	68	68	69	69	70	70	70	70	72	72	72
Cecil TS	215	166	174	179	181	183	185	186	187	188	186	184	182	181	181	181
Charles TS	211	145	151	154	155	156	158	158	159	159	161	164	166	167	175	176
Dufferin TS	170	136	120	123	124	124	125	126	127	129	133	134	138	141	151	155
Duplex TS	128	99	101	100	98	97	94	94	96	97	98	99	100	102	108	113
Esplanade TS	187	163	143	146	147	147	149	149	150	151	150	148	147	144	148	149
Gerrard TS	102	37	46	49	51	51	52	52	52	54	54	54	54	54	55	56
Glengrove TS	88	51	53	53	54	54	54	54	54	54	55	57	58	59	63	65
Main TS	77	60	61	61	63	64	64	64	65	65	67	67	68	69	70	70
Terauley TS	249	175	188	194	190	188	188	191	191	191	190	187	185	184	181	182
Manby E 115 kV																
Fairbank TS	182	171	151	159	164	169	173	176	177	178	179	181	182	182	188	193
Runnymede TS	219	96	136	141	143	143	146	146	148	148	149	149	151	151	158	164
Wiltshire TS	133	56	74	75	75	75	76	76	76	78	78	79	79	79	86	90
Manby W 115 kV																
Copeland MTS	130	0	0	52	93	93	94	94	96	96	98	99	100	102	107	112
John TS	314	264	267	217	203	204	205	206	208	208	212	214	217	220	230	244
Strachan TS	169	139	143	145	146	147	147	149	149	150	155	159	163	167	182	193

(1) Non-coincident station peak, adjusted to extreme weather

(2) Load transferred to the new Horner TS DESN #2 in 2022

Table D-3: Toronto IRRP Load Forecast, with the Impacts of Energy-Efficiency Savings

Area & Station	LTR (MW)	Near & Mid-Term Forecast (MW)												Long-Term Forecast (MW)		
		2018	2019	2020	2021	2022	2023	2024	2025	2026	2027	2028	2029	2030	2035	2040
North 230 kV																
Agincourt TS	174	91	94	96	98	99	100	100	101	101	102	102	102	103	105	108
Bathurst TS	334	208	217	222	225	226	227	229	229	231	231	233	235	237	252	260
Cavanagh MTS	157	90	91	92	92	93	93	93	93	94	95	95	95	96	103	107
Fairchild TS	346	232	233	234	236	237	238	239	241	241	240	241	242	242	244	249
Finch TS	365	247	251	254	256	256	256	257	258	260	261	263	263	263	267	272
Leslie TS	325	230	237	244	245	248	248	250	251	252	252	253	253	253	266	276
Malvern TS	176	82	83	84	85	84	84	85	86	86	88	90	92	93	99	101
East 230 kV																
Bermondsey TS	348	146	150	151	153	155	156	156	157	159	158	159	158	157	157	162
Ellesmere TS	189	123	124	126	127	127	128	128	128	129	128	129	129	128	128	131
Leaside TS	202	149	154	157	160	160	161	160	162	162	162	162	162	161	161	168
Scarboro TS	340	202	204	206	208	208	208	209	210	212	211	211	211	211	219	225
Sheppard TS	205	140	141	143	145	144	146	146	148	148	147	150	152	153	161	167
Warden TS	182	105	106	107	108	109	109	110	109	109	113	115	117	118	125	129
West 230 kV																
Horner TS	365	132	135	136	138	137	139	139	140	141	144	148	152	154	168	177
Manby TS	226	189	199	202	207	208	210	210	211	212	212	214	215	216	227	238
Rexdale TS	187	121	122	123	122	124	123	125	124	124	123	121	120	118	110	102
Richview TS	460	224	209	213	214	215	216	216	216	218	215	213	209	207	200	192
Leaside 115 kV																
Basin TS	88	64	70	74	75	75	75	76	77	76	78	80	80	81	86	90
Bridgman TS	212	152	151	153	154	153	156	156	156	156	157	157	157	159	169	175
Carlaw TS	73	62	63	63	63	64	63	64	64	65	64	64	64	66	65	65
Cecil TS	215	160	167	172	174	175	176	177	177	178	175	173	170	169	167	167
Charles TS	211	143	149	151	152	152	154	153	154	153	155	157	158	159	165	166
Dufferin TS	170	134	119	122	123	122	123	123	124	126	129	130	133	135	143	147
Duplex TS	128	98	99	98	96	95	91	91	93	94	94	95	95	97	102	106
Esplanade TS	187	160	140	142	143	143	144	144	144	145	144	141	140	136	139	140
Gerrard TS	102	32	41	43	45	45	46	46	46	47	46	46	46	46	46	47
Glengrove TS	88	47	49	49	50	50	50	49	49	49	50	52	52	53	56	58
Main TS	77	55	56	56	57	58	57	57	58	58	60	59	60	61	61	61
Terauley TS	249	173	185	190	186	184	183	185	185	184	183	179	177	175	171	172
Manby E 115 kV																
Fairbank TS	182	139	123	130	132	136	138	140	141	141	142	142	143	142	146	149
Runnymede TS	219	95	134	139	140	140	143	142	144	143	144	144	145	144	150	155
Wiltshire TS	133	54	70	71	71	70	71	71	71	73	72	73	73	73	78	81
Manby W 115 kV																
Copeland MTS	130	0	0	51	91	91	92	91	93	93	94	95	96	97	101	106
John TS	314	256	258	207	193	194	194	194	196	195	198	200	202	204	211	224
Strachan TS	169	137	141	142	143	144	143	145	144	145	149	152	156	159	172	182

Table D-4: Toronto Non-Coincident Load Forecast, with the Impacts of Energy-Efficiency Savings

Area & Station	LTR (MW)	Near & Mid-Term Forecast (MW)												Long-Term Forecast (MW)		
		2018 ⁽¹⁾	2019	2020	2021	2022	2023	2024	2025	2026	2027	2028	2029	2030	2035	2040
North 230 kV																
Agincourt TS	174	112	115	118	120	121	122	123	124	124	124	125	125	126	128	133
Bathurst TS	334	227	237	243	246	247	249	250	251	252	252	255	257	259	275	285
Cavanagh MTS	157	108	109	110	111	112	111	111	112	113	114	113	114	115	123	128
Fairchild TS	346	268	269	270	272	273	275	276	277	278	277	278	279	279	282	287
Finch TS	365	290	295	299	301	302	302	303	304	306	307	309	309	310	314	320
Leslie TS	325	233	240	247	248	251	251	253	255	255	255	256	256	256	270	279
Malvern TS	176	105	106	107	108	108	108	109	110	110	113	115	117	118	126	130
East 230 kV																
Bermondsey TS	348	160	164	165	168	169	170	170	171	173	172	173	172	172	171	178
Ellesmere TS	189	124	126	127	128	129	129	129	130	130	130	130	130	130	129	132
Leaside TS	202	163	169	173	176	176	176	176	178	178	177	178	177	177	177	185
Scarboro TS	340	222	224	226	228	228	229	229	231	233	232	231	232	231	241	247
Sheppard TS	205	178	180	182	185	184	186	187	189	188	188	191	194	196	206	213
Warden TS	182	123	124	125	126	127	128	129	128	128	132	135	137	139	146	151
West 230 kV																
Horner TS ⁽²⁾	365	141	145	146	147	189	194	195	196	199	203	209	214	219	247	271
Manby TS ⁽²⁾	226	245	257	260	267	225	225	225	225	225	225	225	225	225	225	225
Rexdale TS	187	136	137	138	137	139	138	140	140	139	139	136	135	133	123	115
Richview TS	460	279	262	266	268	268	270	270	270	272	269	266	261	259	250	240
Leaside 115 kV																
Basin TS	88	65	71	75	75	76	76	77	77	77	79	81	81	82	87	91
Bridgman TS	212	154	153	155	156	155	158	158	158	158	159	159	159	161	171	177
Carlaw TS	73	66	67	67	67	67	67	68	68	69	68	68	68	70	69	69
Cecil TS	215	166	173	178	180	181	183	183	183	184	182	179	176	175	173	173
Charles TS	211	145	150	153	154	154	155	155	156	155	157	159	160	161	167	168
Dufferin TS	170	136	119	122	123	123	123	124	124	126	129	130	133	136	144	148
Duplex TS	128	99	101	99	97	96	93	92	94	95	95	96	96	98	103	108
Esplanade TS	187	163	143	145	146	146	147	147	147	148	147	144	143	139	142	143
Gerrard TS	102	37	47	50	52	52	53	53	53	54	53	53	53	53	53	54
Glengrove TS	88	51	52	52	53	53	53	53	53	52	53	55	56	57	60	62
Main TS	77	60	61	61	62	63	63	62	63	63	65	65	66	66	67	67
Terauley TS	249	175	187	193	188	186	185	188	187	187	185	181	179	177	173	174
Manby E 115 kV																
Fairbank TS	182	171	150	158	162	167	171	173	173	174	175	176	176	175	179	184
Runnymede TS	219	96	63	115	157	156	158	157	160	159	161	161	162	164	170	178
Wiltshire TS	133	56	74	75	74	74	75	75	75	76	76	77	77	77	83	86
Manby W 115 kV																
Copeland MTS	130	0	0	51	91	91	92	91	93	93	94	95	96	97	101	106
John TS	314	264	265	215	200	200	201	201	202	202	205	207	209	211	219	232
Strachan TS	169	139	143	144	145	146	145	147	146	147	151	155	158	161	174	184

(1) Non-coincident station peak, adjusted to extreme weather

(2) Load transferred to the new Horner TS DESN #2 in 2022