

Greater Bruce - Huron REGIONAL INFRASTRUCTURE PLAN

August 18, 2017



[This page is intentionally left blank]

Prepared and supported by:

Company
Hydro One Networks Inc. (Lead Transmitter)
Entegrus Power Lines Inc.
Erie Thames Powerlines Corporation
Festival Hydro Inc.
Goderich Hydro - West Coast Huron Energy Inc.
Hydro One Networks Inc. (Distribution)
Independent Electricity System Operator
Wellington North Power Inc.
Westario Power Inc.

[This page is intentionally left blank]

Disclaimer

This Regional Infrastructure Plan (“RIP”) report was prepared for the purpose of developing an electricity infrastructure plan to address all near and mid-term needs (2016-2025) identified in previous planning phases and any additional needs identified based on new and/or updated information provided by the RIP Working Group.

The preferred solution(s) that have been identified in this report may be reevaluated based on the findings of further analysis. The load forecast and results reported in this RIP report are based on the information provided and assumptions made by the participants of the RIP Working Group.

Working Group participants, their respective affiliated organizations, and Hydro One Networks Inc. (collectively, “the Authors”) make no representations or warranties (express, implied, statutory or otherwise) as to the RIP report or its contents, including, without limitation, the accuracy or completeness of the information therein and shall not, under any circumstances whatsoever, be liable to each other, or to any third party for whom the RIP report was prepared (“the Intended Third Parties”), or to any other third party reading or receiving the RIP report (“the Other Third Parties”), for any direct, indirect or consequential loss or damages or for any punitive, incidental or special damages or any loss of profit, loss of contract, loss of opportunity or loss of goodwill resulting from or in any way related to the reliance on, acceptance or use of the RIP report or its contents by any person or entity, including, but not limited to, the aforementioned persons and entities.

[This page is intentionally left blank]

EXECUTIVE SUMMARY

THIS REGIONAL INFRASTRUCTURE PLAN (“RIP”) WAS PREPARED BY HYDRO ONE AND THE WORKING GROUP IN ACCORDANCE WITH THE ONTARIO TRANSMISSION SYSTEM CODE REQUIREMENTS. IT IDENTIFIES INVESTMENTS IN TRANSMISSION FACILITIES, DISTRIBUTION FACILITIES, OR BOTH, THAT SHOULD BE PLANNED AND IMPLEMENTED TO MEET THE ELECTRICITY INFRASTRUCTURE NEEDS WITHIN THE GREATER BRUCE-HURON REGION.

The participants of the RIP Working Group included members from the following organizations:

- Hydro One Networks Inc. (Lead Transmitter)
- Entegrus Power Lines Inc.
- Erie Thames Powerlines Corporation
- Festival Hydro Inc.
- Goderich Hydro - West Coast Huron Energy Inc.
- Hydro One Networks Inc. (Distribution)
- Independent Electricity System Operator
- Wellington North Power Inc.
- Westario Power Inc.

This RIP is the final phase of the regional planning process for the Greater Bruce-Huron Region and provides a consolidated summary of needs and recommended plans for the Greater Bruce-Huron Region for the near-term (up to 5 years) and mid-term (5 to 10 years). No long term needs (10 to 20 years) have been identified.

Investments planned for the Greater Bruce-Huron Region over the near and mid-term, identified in the various phases of the regional planning process, are given in the table below.

No.	Project	In-Service Date	Cost
1	Improve L7S Customer Delivery Point Performance	Staged Plan 2017-2023	\$154k - TBD
2	Accommodation for Connection Capacity Requests near Kincardine– Hydro One Network Inc. Distribution	TBD (customer dependent)	TBD

In accordance with the Regional Planning process, the RIP should be reviewed and/or updated at least every five years. The Region will continue to be monitored and should there be a need that emerges earlier due to a change in load forecast or any other reason, the next regional planning cycle will be started to address the need.

Table of Contents

1. Introduction	10
1.1 Objective and Scope	11
1.2 Structure.....	11
2. Regional Planning Process.....	12
2.1 Overview	12
2.2 Regional Planning Process	12
2.3 RIP Methodology	15
3. Regional Characteristics.....	16
4. Transmission Facilities Completed Over Last Ten Years Or Currently Underway	19
5. Load Forecast And Study Assumptions	21
5.1 Load Forecast	21
5.2 Study Assumptions.....	23
6. Adequacy Of Facilities and Regional Needs Over the 2016-2025 Period	24
6.1 230 kV Transmission Facilities	26
6.2 500/230 kV and 230/115 kV Transformation Facilities	26
6.3 Supply Capacity of the 115 kV Network.....	27
6.4 Step-down Transformer Stations	27
6.5 Other Items Identified During Regional Planning.....	28
6.5.1 Customer Delivery Point Performance	28
6.5.2 Low Power Factor Concerns	28
6.6 Long-Term Regional Needs	28
7. Regional Plans	29
7.1 Transmission Circuit Capacity	29
7.2 Power Factor Review.....	29
7.3 Customer Delivery Point Performance	30
7.4 Step-Down Transformation Capacity	32
7.5 Transmission Sustainment Plans	32
8. Conclusion.....	34
9. References	35
Appendix A: Step-Down Transformer Stations in the Greater Bruce-Huron Region	36
Appendix B: Regional Transmission Circuits in the Greater Bruce-Huron Region	37
Appendix C: Distributors in the Greater Bruce-Huron Region	38
Appendix D: Regional Load Forecast (2016-2025).....	39
Appendix E: RIP Transmission Adequacy Assessment.....	47
Appendix F: Customer Delivery Point Performance Review	48
Appendix G: List of Acronyms.....	52

List of Figures

Figure 2-1 Regional Planning Process Flowchart..... 14
 Figure 2-2 RIP Methodology 15
 Figure 3-1 Geographical Area of the Greater Bruce-Huron Region with Electrical Layout 17
 Figure 3-2 Greater Bruce-Huron Region Single Line Diagram..... 18
 Figure 5-1 Greater Bruce-Huron Region Winter Extreme Weather Peak Forecast 22
 Figure 5-2 Greater Bruce-Huron Region Summer Extreme Weather Peak Forecast..... 22

List of Tables

Table 6-1: Near and Mid-term Regional Needs..... 25
 Table 7-1: Hydro One Transmission Major Sustainment Initiatives 32
 Table 8-1: Regional Plans – Next Steps, Lead Responsibility and Plan In-Service Dates 34
 Table F-1 - Customer Delivery Points 48

1. INTRODUCTION

THIS REPORT PRESENTS THE REGIONAL INFRASTRUCTURE PLAN (“RIP”) TO ADDRESS THE ELECTRICITY NEEDS OF THE GREATER BRUCE-HURON REGION.

The report was prepared by Hydro One Networks Inc. (“Hydro One”) and documents the results of the joint study carried out by Hydro One, Entegrus Power Lines Inc., Erie Thames Powerlines Corporation, Festival Hydro Inc., Hydro One Distribution, the Independent Electricity System Operator (“IESO”), Wellington North Power Inc., Goderich Hydro - West Coast Huron Energy Inc. and Westario Power Inc. in accordance with the Regional Planning process established by the Ontario Energy Board (“OEB”) in 2013.

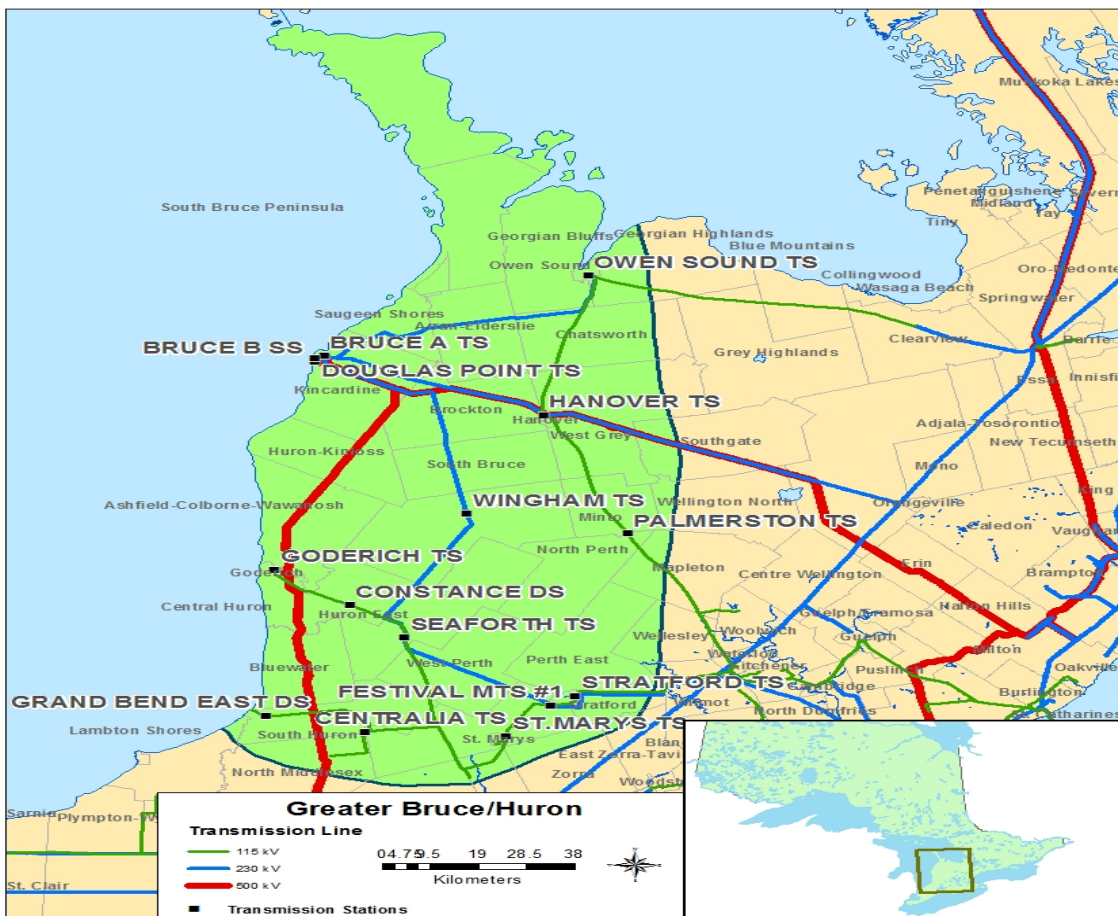

Figure 1-1 Greater Bruce-Huron Region

The Greater Bruce-Huron Region includes the counties of Bruce, Huron and Perth, as well as portions of Grey, Wellington, Waterloo, Oxford and Middlesex counties. Electrical supply to the Region is provided from six 230 kV and twelve 115 kV step-down transformer stations. The boundaries of the Region are highlighted in Figure 1-1 above.

1.1 Objective and Scope

This RIP report examines the needs in the Greater Bruce-Huron Region. Its objectives are:

- To develop a wires plan to address needs identified in previous planning phases for which a wires only alternative was recommended by the Working Group
- To identify new supply needs that may have emerged since previous planning phases (e.g. Needs Assessment, Scoping Assessment, Local Plan, and/or Integrated Regional Resource Plan)
- To provide the status of wires planning currently underway or completed for specific needs
- To identify investments in transmission and distribution facilities or both that should be developed and implemented on a coordinated basis to meet the electricity infrastructure needs within the region

The RIP reviewed factors such as the load forecast, major high voltage sustainment work, transmission and distribution system capability along with any updates with respect to local plans, conservation and demand management (CDM), renewable and non-renewable generation development, and other electricity system and local drivers that may impact the need and alternatives under consideration.

The scope of this RIP is as follows:

- A consolidated report of all the needs and relevant plans to address near and mid-term needs (2016-2025) identified in previous planning phases (Needs Assessment or Local Plan)
- Identification of any new needs over the 2016-2025 period
- Develop a plan to address any longer term needs identified by the Working Group

1.2 Structure

The rest of the report is organized as follows:

- Section 2 provides an overview of the regional planning process
- Section 3 describes the region
- Section 4 describes the transmission work completed over the last ten years
- Section 5 describes the load forecast and study assumptions used in this assessment
- Section 6 describes the results of the adequacy assessment of the transmission facilities and identifies needs
- Section 7 summarizes the Regional Plan to address the needs
- Section 8 provides the conclusion and next steps

2. REGIONAL PLANNING PROCESS

2.1 Overview

Planning for the electricity system in Ontario is done at essentially three levels: bulk system planning, regional system planning, and distribution system planning. These levels differ in the facilities that are considered and the scope of impact on the electricity system. Planning at the bulk system level typically looks at issues that impact the system on a provincial level, while planning at the regional and distribution levels looks at issues on a more regional or localized level.

Regional planning looks at supply and reliability issues at a regional or local area level. Therefore, it largely considers the 115 kV and 230 kV portions of the power system that supply various parts of the province.

2.2 Regional Planning Process

A structured regional planning process was established by the Ontario Energy Board in 2013, through amendments to the Transmission System Code (“TSC”) and the Distribution System Code (“DSC”). The process consists of four phases: the Needs Assessment¹ (“NA”), the Scoping Assessment (“SA”), the Integrated Regional Resource Plan (“IRRP”), and the Regional Infrastructure Plan (“RIP”).

The regional planning process begins with the NA phase which is led by the transmitter to determine if there are regional needs. The NA phase identifies the needs and the Working Group determines whether further regional coordination is necessary to address them. If no further regional coordination is required, further planning is undertaken by the transmitter and the impacted local distribution company (“LDC”) or customer and develops a Local Plan (“LP”) to address them. These needs are local in nature and can be best addressed by a straight forward wires solution.

In situations where identified needs require coordination at the regional or sub-regional levels, the IESO initiates the SA phase. During this phase, the IESO, in collaboration with the transmitter and impacted LDCs, reviews the information collected as part of the NA phase, along with additional information on potential non-wires alternatives, and makes a decision on the most appropriate regional planning approach. The approach is either a RIP, which is led by the transmitter, or an IRRP, which is led by the IESO. If more than one sub-region was identified in the NA phase, it is possible that a different approach could be taken for different sub-regions.

The IRRP phase will generally assess infrastructure (wires) versus resource options (e.g. CDM, generation and Distributed Energy Resources (“DER”)) at a higher or more macro level but sufficient to permit a comparison of options. If the IRRP process identifies that infrastructure options may be most appropriate to meet a need, the RIP phase will conduct detailed planning to identify and assess the

¹ Also referred to a Needs Screening

specific wires alternatives and recommend the preferred wires solution. Similarly, resource options which the IRRP identifies as best suited to meet a need are then further planned in greater detail by the IESO. The IRRP phase also includes IESO led stakeholder engagement with municipalities and establishes a Local Advisory Committee in the region or sub-region.

The RIP phase is the final stage of the regional planning process and involves: confirmation of previously identified needs; identification of any new needs that may have emerged since the start of the planning cycle; and development of a wires plan to address the needs where a wires solution was determined to be the best overall approach. This phase is led and coordinated by the transmitter and the deliverable of this stage is a comprehensive report of a wires plan for the region. Once completed, this report can be referenced in rate filing submissions or as part of LDC rate applications with a planning status letter provided by the transmitter. Reflecting the timeliness provisions of the RIP, plan level stakeholder engagement is not undertaken at this stage. However, stakeholder engagement at a project specific level will be conducted as part of the project approval requirement.

To efficiently manage the regional planning process, Hydro One has been undertaking wires planning activities in collaboration with the IESO and/or LDCs for the Greater Bruce-Huron region as part of and/or in parallel with:

- Planning activities that were already underway in the region prior to the new regional planning process taking effect.
- The NA and LP phases of regional planning.
- Working and planning for connection capacity requirements with the LDCs and transmission connected customers

Figure 2-1 illustrates the various phases of the regional planning process (NA, SA, IRRP, and RIP) and their respective phase trigger, lead, and outcome.

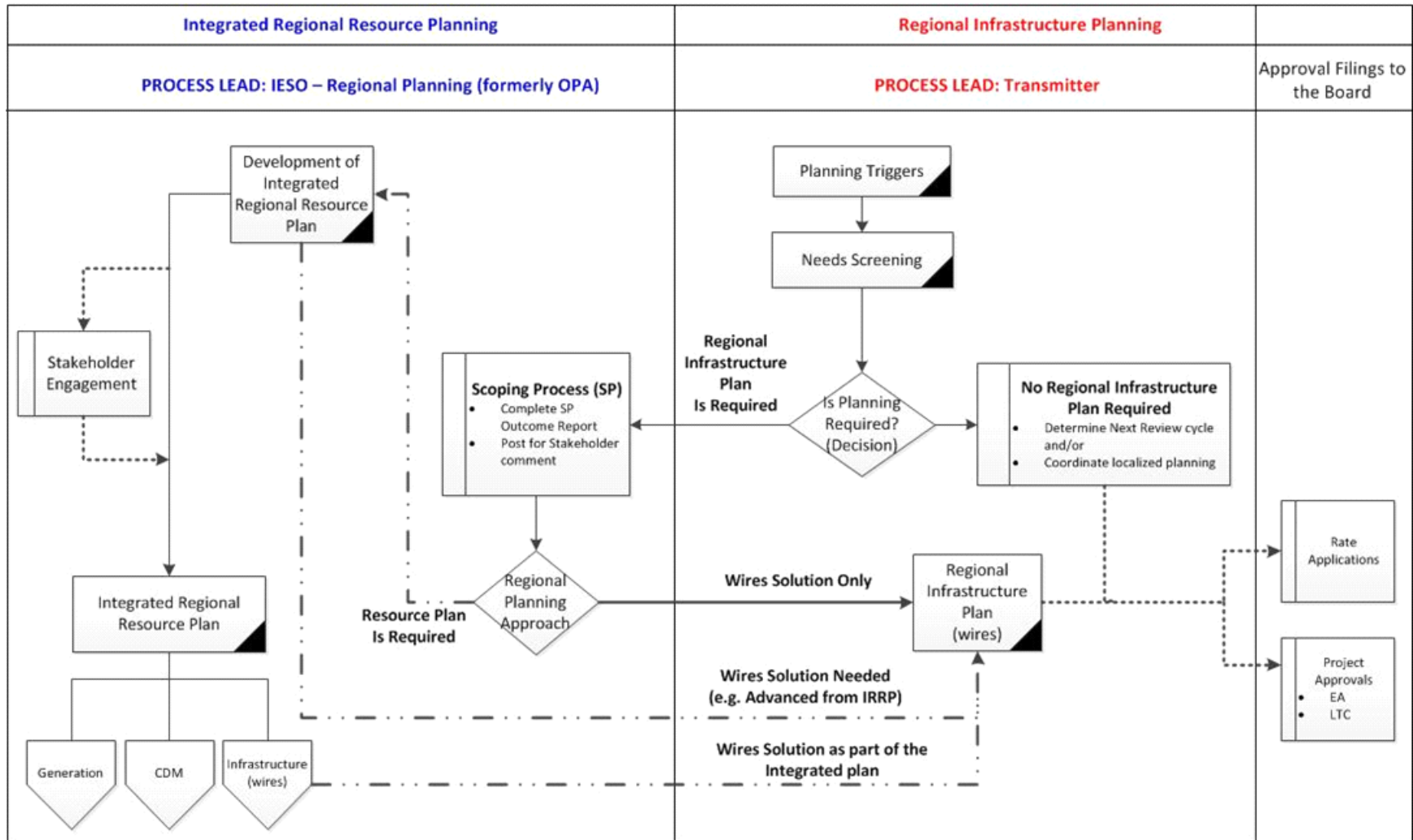

Figure 2-1 Regional Planning Process Flowchart

2.3 RIP Methodology

The RIP phase consists of four steps (see Figure 2-2) as follows:

1. **Data Gathering:** The first step of the RIP phase is the review of planning assessment data collected in the previous stages of the regional planning process. Hydro One collects this information and reviews it with the Working Group to reconfirm or update the information as required. The data collected includes:
 - Gross and net peak demand forecast at the transformer station level. This includes the effect of any distributed generation and/or conservation and demand management programs.
 - Existing area network and capabilities including any bulk system power flow assumptions.
 - Other data and assumptions as applicable such as asset conditions; load transfer capabilities, and previously committed transmission and distribution system plans.
2. **Technical Assessment:** The second step is a technical assessment to review the adequacy of the regional system including any previously identified needs. Additional near and mid-term needs may be identified at this stage.
3. **Alternative Development:** The third step is the development of wires options to address the needs and to come up with a preferred alternative based on an assessment of technical considerations, feasibility, environmental impact and costs.
4. **Implementation Plan:** The fourth and last step is the development of the implementation plan for the preferred alternative.

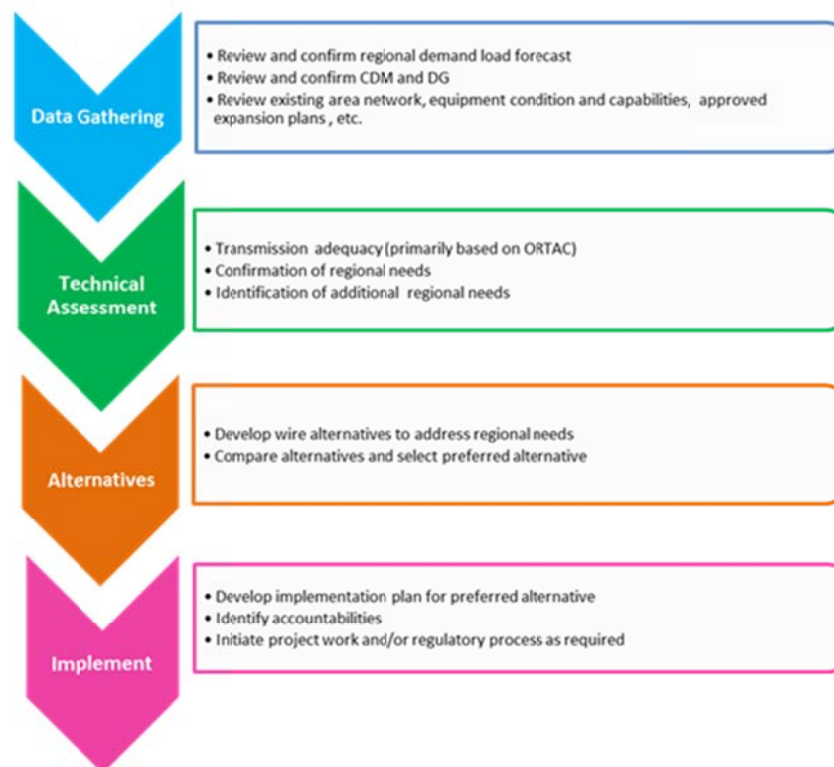

Figure 2-2 RIP Methodology

3. REGIONAL CHARACTERISTICS

THE GREATER BRUCE-HURON REGION COMPRISES OF THE COUNTIES OF BRUCE, HURON, AND PERTH, AS WELL AS PORTIONS OF GREY, WELLINGTON, WATERLOO, OXFORD, AND MIDDLESEX COUNTIES AS SHOWN IN FIGURE 3-1.

Electricity supply for the Region is provided through a network of 230 kV and 115 kV transmission lines supplied mainly by generation from the Bruce Nuclear Generating Station and local renewable generation facilities in the Region. The majority of the electrical supply in the region is transmitted through 230 kV circuits (B4V, B5V, B22D, B23D, B27S and B28S) radiating out from Bruce A TS. These circuits connect the Region to the adjacent South Georgian Bay/Muskoka Region and the adjacent Kitchener-Waterloo-Cambridge-Guelph (KWCG) Region.

Within the Region, electricity is delivered to the end users of LDCs and directly-connected industrial customers by eleven Hydro One step-down transformation stations, as well as seven customer-owned transformer or distribution stations supplied directly from the transmission system. Appendix A lists all step-down transformer stations in the Region. Appendix B lists all transmission circuits and Appendix C lists LDCs in the Region. The Single Line Diagram for the Greater Bruce-Huron Region transmission system facilities is shown below in Figure 3-2.



Figure 3-1 Geographical Area of the Greater Bruce-Huron Region with Electrical Layout

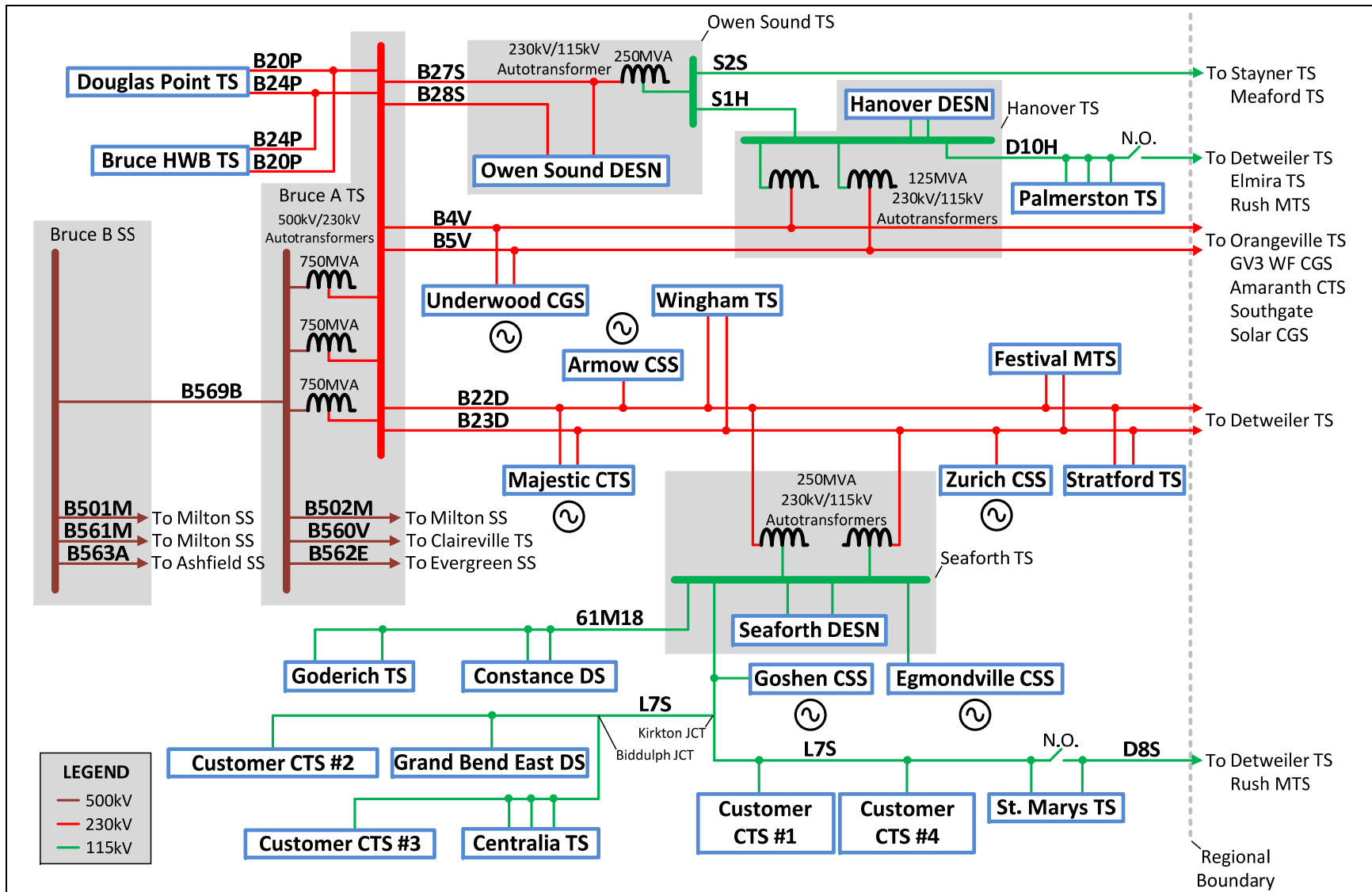

Figure 3-2 Greater Bruce-Huron Region Single Line Diagram

4. TRANSMISSION FACILITIES COMPLETED OVER LAST TEN YEARS OR CURRENTLY UNDERWAY

OVER THE LAST 10 YEARS A NUMBER OF TRANSMISSION PROJECTS HAVE BEEN PLANNED AND COMPLETED BY HYDRO ONE, OR ARE UNDERWAY, AIMED AT IMPROVING THE SUPPLY TO THE GREATER BRUCE-HURON REGION.

In addition to Hydro One's ongoing transmission station and line sustainment programs, specific projects were identified as a result of joint planning studies undertaken by Hydro One, IESO and the LDCs; or initiated to meet the needs of the LDCs; and/or to meet Provincial Government policies. A brief listing of the completed projects is given below.

For reactive and voltage support needs:

- a 230 kV shunt capacitor bank installed at Detweiler TS in 2007
- a 230 kV shunt capacitor bank installed at Orangeville TS in 2008

For bulk power system transfer needs:

- 500 kV double circuit line from the Bruce Nuclear Complex to Milton SS in 2011
- 230 kV Static Var Compensator (SVC) at Detweiler TS in 2011

For major station refurbishment needs based on asset condition assessment:

- Goderich TS in 2016

For renewable generation connection needs:

- 230 kV Melancthon Grey Wind Farm onto circuits B4V/B5V in 2006/2008
- 230 kV Ripley Wind Farm onto circuits B22D/B23D in 2007
- 230 kV Underwood Wind Farm onto circuits B4V/ B5V in 2008
- 230 kV Dufferin Wind Farm into Orangeville TS in 2014
- 500 kV Jericho/Adelaide/Bornish Wind Farms into Evergreen SS in 2014
- 230 kV Grand Valley 3 Wind Farm onto circuit B4V in 2015
- 115 kV Bluewater Wind Farm into Seaforth TS in 2015
- 115 kV Goshen Wind Farm onto circuit L7S in 2015
- 500 kV K2 Wind Farm into Ashfield SS in 2015
- 230 kV Grand Bend Wind Farm onto circuit B23D in 2016
- 230 kV Armow Wind Farm onto circuit B22D in 2016
- 230 kV Southgate Solar Farm onto circuit B4V in 2016

The following projects are underway:

- Centralia TS is currently undergoing major station refurbishment work with a projected in-service of 2018.
- Palmerston TS is currently undergoing major station refurbishment work with a projected in-service of 2018.
- Bruce A TS 230 kV switchyard is currently undergoing major station refurbishment work with a projected in-servicing by 2019.
- Replacement of the Bruce Special Projection Scheme (BSPS) is currently underway with a projected in-service of 2018.
- Modification to the Bruce Reactor Switching Scheme (RSS) is currently underway with a projected in-service of 2018.

5. LOAD FORECAST AND STUDY ASSUMPTIONS

5.1 Load Forecast

The load in the Greater Bruce-Huron Region is forecast to increase annually between 2016 and 2025. The growth rate varies across the Region with most of the growth concentrated in the County of Bruce and more specifically in the Kincardine area. The Region's 2017 RIP load forecasts are provided in Appendix D and were prepared by the Working Group upon initiation of the RIP phase. The RIP forecasts are identical to the Needs Assessment forecast except as otherwise noted in Appendix D.

As per the load forecasts in Appendix D, the winter *gross* coincident load in the Region is expected to grow at an average rate of approximately 1.4% annually from 2016-2025 and the summer *gross* coincident load in the Region is expected to grow at an average rate of approximately 1.3% from 2016-2025.

As per the load forecasts in Appendix D, the winter *net* coincident load in the Region is expected to grow at an average rate of approximately 0.8% annually from 2016-2025 and the summer *net* coincident load in the Region is expected to grow at an average rate of approximately 0.6% from 2016-2025.

Figure 5-1 shows the Region's gross and net *winter* coincident forecasts while Figure 5.2 shows the Region's gross and net *summer* coincident forecasts. The regional-coincident (at the same time) forecast represents the total peak load of all 18 step-down transformer stations in the Region.

Based on historical load and on the coincident load forecasts, the Region's winter coincident peak load is larger than its summer coincident peak load. Based on historical load and the non-coincident load forecasts, the Region contains some stations that are summer peaking and others that are winter peaking. Equipment ratings are normally lower in the summer than winter due to ambient temperature. Based on these factors assessment for this Region was conducted for both summer and winter peak load.

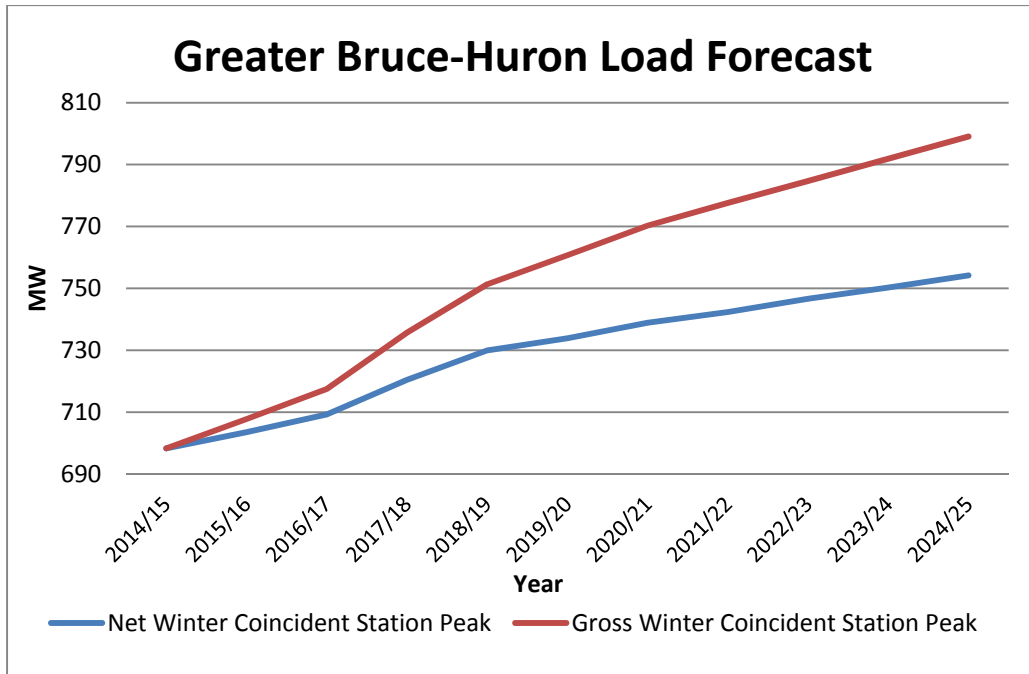

Figure 5-1 Greater Bruce-Huron Region Winter Extreme Weather Peak Forecast

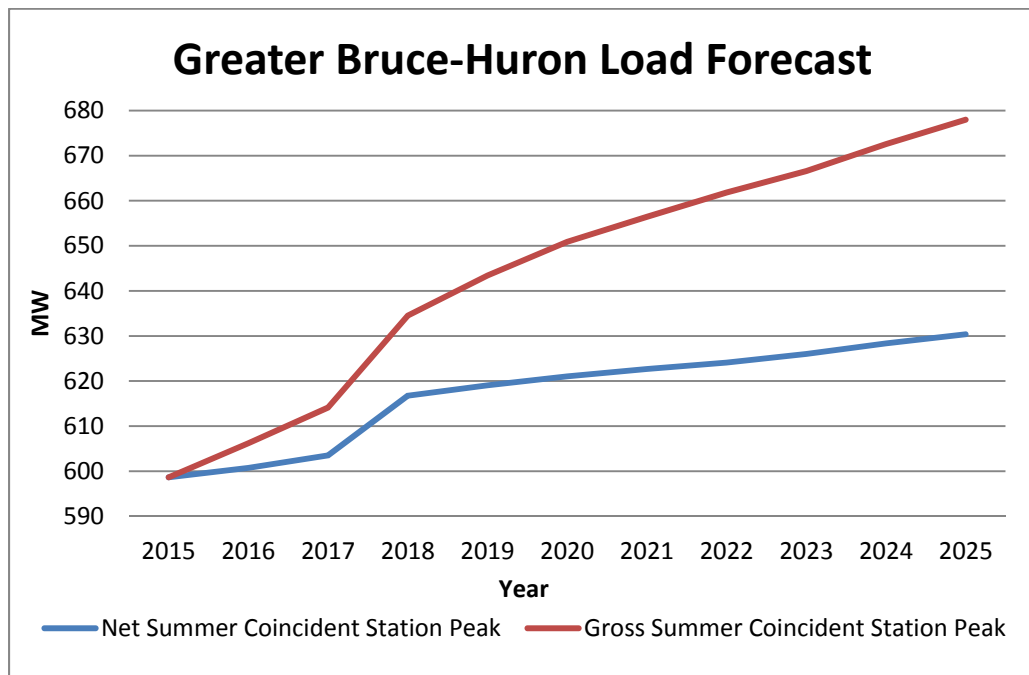

Figure 5-2 Greater Bruce-Huron Region Summer Extreme Weather Peak Forecast

5.2 Study Assumptions

The following assumptions are made in this report.

- 1) The study period for the RIP assessments is 2016-2025.
- 2) All planned facilities listed in Section 4 are assumed to be in-service.
- 3) The Region contains some stations that are summer peaking and others that are winter peaking. The assessment is therefore based on both summer and winter peak loads.
- 4) Station capacity adequacy is assessed by comparing the non-coincident peak load with the station's normal planning supply capacity by assuming a 90% lagging power factor for stations without low-voltage capacitor banks or the historical low voltage power factor, whichever is more conservative. Normal planning supply capacity for transformer stations in this Region is determined by the summer and winter 10-Day Limited Time Rating (LTR), as appropriate.
- 5) Adequacy assessment is conducted as per Ontario Resource Transmission Assessment Criteria (ORTAC).

6. ADEQUACY OF FACILITIES AND REGIONAL NEEDS OVER THE 2016-2025 PERIOD

THIS SECTION REVIEWS THE ADEQUACY OF THE EXISTING TRANSMISSION SYSTEM AND STEP-DOWN TRANSFORMATION STATION FACILITIES SUPPLYING THE GREATER BRUCE-HURON REGION AND LISTS THE FACILITIES REQUIRING REINFORCEMENT OVER THE NEAR AND MID-TERM.

Within the current regional planning cycle, five regional assessments have been conducted for the Greater Bruce-Huron Region. The findings of these studies are input to the RIP. The studies are:

- 1) Needs Assessment Report - Greater Bruce-Huron Region, May 2016
- 2) Local Planning Report - Low Power Factor at Wingham TS, October 2016
- 3) Local Planning Report - Circuit L7S Thermal Overload, November 2016
- 4) Local Planning Report - Low Power Factor at Bruce HWP B TS, May 2017
- 5) Customer Delivery Point Performance Review, 2016-2017

This RIP reviewed the loading on transmission lines and stations in the Greater Bruce-Huron Region based on the RIP load forecast. Sections 6.1-6.6 presents the results of this review and Table 6-1 lists the Region's needs identified in both the Needs Assessment and the RIP phases.

In addition, this RIP reviewed an updated list of Hydro One transmission lines and station major sustainment work over the next several years to determine if there are opportunities to consolidate with any emerging development needs within the Region. Section 7.5 presents the results of this review.

Table 6-1: Near and Mid-term Regional Needs

Type	Section	Needs	Timing
Needs Identified in the Needs Assessment Report ^[1]			
Transmission Circuit Capacity	6.3	Overload on sections of 115 kV single circuit line, L7S	2019 (based on gross load forecast)
			2025 (based on net load forecast)
Power Factor Review	6.5.2	Low power factor at Wingham TS	Immediate
		Low power factor at Bruce HWP B TS	Immediate
Customer Delivery Point Performance Review	6.5.1	Delivery points supplied from 115 kV circuits 61M18, L7S and D10H	Immediate
Additional Needs identified in RIP Phase			
Step-down Transformation Capacity	6.4	Hydro One Distribution (Kincardine area)	2019/2020

6.1 230 kV Transmission Facilities

Half of the 230 kV transmission circuits in the Greater Bruce-Huron Region are classified as part of the Bulk Electricity System (“BES”). They connect the Region to the rest of Ontario’s transmission system and are also part of the transmission path from generation in Southwestern Ontario to the load centers in the KWCG, Georgian Bay and GTA areas. These circuits also serve local area stations within the Region and the power flow on them depends on the bulk system transfer as well as local area loads. These circuits are as follows (refer to Figure 3-2):

- 1) Bruce A TS to Orangeville TS 230kV transmission circuits B4V/B5V – supplies Hanover TS
- 2) Bruce A TS to Detweiler TS 230kV transmission circuits B22D/ B23D – supplies Wingham TS, Seaforth TS, Festival MTS #1, and Stratford TS
- 3) Bruce A TS to Owen Sound TS 230kV transmission circuits B27S/B28S – supplies Owen Sound TS
- 4) Bruce A TS to Douglas Point TS 230kV transmission circuits B20P/B24P – supplies Douglas Point TS and Bruce HWP B TS

The RIP review shows that based on current forecast station loadings and bulk transfers, all 230 kV circuits are expected to be adequate over the study period.

6.2 500/230 kV and 230/115 kV Transformation Facilities

Bulk power supply to the Greater Bruce-Huron Region is provided by Hydro One’s 500 kV to 230 kV and 230 kV to 115 kV autotransformers. The number and location of these autotransformers are as follows:

- 1) Three (3) 500/230kV autotransformers at Bruce A TS
- 2) Two (2) 230/115kV autotransformers at Seaforth TS
- 3) Two (2) 230/115kV autotransformers at Hanover TS

The RIP review shows that based on current forecast station loadings and bulk transfers, the autotransformation supply capacity is adequate over the study period.

6.3 Supply Capacity of the 115 kV Network

The Greater Bruce-Huron Region contains four (4) single circuit 115 kV lines. This 115 kV network serves local area load. These circuits are as follows (see Figure 3-2):

- 1) Hanover TS to Detweiler TS 115 kV transmission circuit D10H with Normally Open (N/O) point at Palmerston TS – supplies Palmerston TS & Elmira TS
- 2) Seaforth TS to Goderich TS 115 kV transmission circuit 61M18 – supplies Constance DS and Goderich TS
- 3) Seaforth TS to St. Marys TS 115 kV transmission circuit L7S – supplies Grand bend East DS, Lake Huron WTP CTS, Centralia TS, McGillivray R&BP CTS, Enbridge Bryanston CTS and St. Marys Cement CTS
- 4) Hanover TS to Owen Sound TS 115 kV transmission circuit S1H

The RIP review shows that based on current forecast station loadings, the supply capacity of the 115 kV network is adequate over the study period, except circuit L7S. Circuit L7S will exceed its thermal rating in 2019 based on gross load forecast, and in 2025 based on net load forecast.

6.4 Step-down Transformer Stations

There are 18 step-down transformer stations within the Greater Bruce-Huron Region. Fourteen supply electricity to LDCs and four are transmission-connected industrial customer stations. These stations are listed in Appendix C. Of the 18 stations, 3 of them are owned and operated by LDCs.

As part of both the Needs Assessment as well as this RIP, step-down transformation station capacity was reviewed. Since the May 2016 Needs Assessment, the load forecasts at Seaforth TS, Stratford TS and Douglas Point TS have been modified; refer to Appendix E for the analysis of these modifications. The analysis showed that the load forecasts at Seaforth TS and Stratford TS can still be accommodated. However, the load forecast modification at Douglas Point TS will result in its transformation capacity limit being exceeded towards the end of the study period, winter 2023/2024. This is due to a 15 MW request for capacity made since the May 2016 Needs Assessment.

Furthermore, since updating the RIP forecast there has been additional connection requests for 2.2 MW, 0.5 MW and 20 MW of capacity by 2019/2020 at Douglas Point TS. The 2.2 MW and 0.5 MW requests can be accommodated within the station's transformation capacity limits; however the 20 MW request would result in Douglas Point TS exceeding its transformation capacity within the near term (2019/2020) and cannot be fully accommodated at this time. Therefore additional step-down transformation capacity at/near Douglas Point TS is needed.

Based on the requirements of the customer requesting the 20 MW of connection capacity, three “need” scenarios have been developed:

Scenario 1 – If the customer requires all 20 MW of capacity immediately, the need for additional step-down transformation capacity is required in 2019/2020. Hydro One Transmission will work with Hydro One Distribution and the customer to develop a plan to meet the increased capacity requirement. All costs for the additional capacity will be allocated to the benefitting customer(s) as per the Transmission System Code.

Scenario 2 – If the customer accepts an offering to connect a portion of its load, the need for additional step-down transformation capacity is required in 2021 due to the inherent “organic” growth of load. In order to meet the need timeline, an expedited coordinated regional planning process will be undertaken by the IESO, Hydro One Transmission and Hydro One Distribution. Cost allocation for additional investment will depend on the solution to address the need.

Scenario 3 – If the customer elects not to proceed with its connection request, the need for additional step-down transformation capacity is required by 2023/2024. CDM would help to defer the need and therefore it is recommended to monitor load growth and re-evaluate the need in the next regional planning cycle.

6.5 Other Items Identified During Regional Planning

6.5.1 Customer Delivery Point Performance

The Needs Assessment section 6.2.5 identified that a performance review of several 115 kV customer delivery points be undertaken. A summary of the review is provided in Appendix F.

6.5.2 Low Power Factor Concerns

The Needs Assessment sections 6.2.3 identified two stations which historically have low power factor: Wingham TS and Bruce HWB TS.

6.6 Long-Term Regional Needs

A long-term, beyond 10 year, analysis was not deemed necessary by the Working Group for the Region at this time and therefore no long-term studies have been undertaken. If new long-term needs were to arise, there is sufficient time to assess them in the next planning cycle which can also be started earlier to make timely investment decisions.

7. REGIONAL PLANS

THIS SECTION SUMMARIZES THE REGIONAL PLANS FOR ADDRESSING THE NEEDS LISTED IN TABLE 6-1.

7.1 Transmission Circuit Capacity

7.1.1 Circuit L7S

L7S is a single 115 kV circuit transmission line operated radial from Seaforth TS to St. Marys TS. As per section 6.1.3 of the Needs Assessment, the circuit will reach its Load Meeting Capability (“LMC”) in 2019 based on the gross load forecast and 2025 based on the net load forecast.

Recommended Plan and Current Status

To address the transmission circuit capacity needs for L7S, the Local Planning working group created a Development Plan which recommended monitoring load growth at stations supplied from circuit L7S. The Development Plan is detailed in the Local Planning report^[3]. The Development Plan specified that when loading on L7S is expected to exceed its limits within a 3 year period, Hydro One Transmission will increase the thermal rating of the limiting spans of circuit L7S. The cost to increase the rating is currently estimated to be approximately \$550 k. Strengthening L7S will be sufficient for supplying load connected to L7S load for the study period. Loading beyond the study period’s forecast may then require additional voltage support. Capacity cost allocation will be as per the Transmission System Code.

Current Status of the Loading on Circuit L7S

The past winter (2016/2017) loading on circuit L7S was reviewed in accordance with the Development Plan. Winter peak coincident loading on the circuit was approximately 65% of the circuit capacity and did not trigger the need to increase the rating. Monitoring will continue after each peak load season, winter and summer.

7.2 Power Factor Review

7.2.1 Wingham TS

Power factor at Wingham TS is often low and does not meet IESO Market Rule requirements. As per section 6.2.3 of the Needs Assessment, the low power factor at Wingham TS is to be managed by the transmitter and affected LDCs.

Recommended Plan and Current Status

The power factor review conducted by the Local Planning working group, showed that the power factor of the load itself remains within Market Rule requirements. Further investigation revealed that the low power factor is due to the connected Distributed Generation (DG). The investigation is detailed in the Local Planning report ^[2]. The Local Plan recommends no mitigation is required at this time and to seek IESO's direction on power factor requirements with respect to DG.

Current Status of Power Factor with Respect to Distributed Generation

At this time, IESO does not recommend a Market Rule power factor amendment as the measured power factor is due to the connected DG and asks that a case by case review be conducted when the power factor consistently does not meet the Market Rule requirement.

7.2.2 Bruce HWP B TS

Power factor at Bruce HWP B TS is often low and does not meet IESO Market Rule requirements. As per section 6.2.3 of the Needs Assessment, the low power factor at Bruce HWP B TS is to be managed by the transmitter and the affected customer.

Recommended Plan

The power factor review conducted by the Local Planning working group, showed that while the power factor of the load occasionally (rather than often as previously identified) does not meet Market Rule requirements there is no negative effect at this time. The investigation is detailed in the Local Planning report ^[4]. The Local Plan recommends no mitigation is required at this time.

7.3 Customer Delivery Point Performance

7.3.1 Customers Supplied from Circuit 61M18

The performance of delivery points supplied from circuit 61M18, specifically Constance DS and Goderich TS were reviewed. The review is summarized in Appendix F, section F.1.

Recommended Plan and Current Status

To address delivery point performance to Constance DS and Goderich TS, it is recommended that Hydro One Transmission continue to rely on its line and station maintenance programs, as well as capital sustainment projects listed in section 4.0 and in Table 7-1 to improve the overall reliability.

Current Status of Sustainment Work associated 61M18 Delivery Points

The 17 remaining original 1959 structures on circuit 61M18 along with 11 other structures are schedule to be tested over the next 2 years. Those that are determined to be End-Of-Life (in poor condition), will then be replaced in the next 5 years. These replacements will occur under Hydro One's Line Sustainment programs.

7.3.2 Customers Supplied from Circuit L7S

The performance of delivery points supplied from circuit L7S, specifically Centralia TS, Grand Bend East DS, St. Marys TS and the 4 industrial customer connections, were reviewed. The review is summarized in Appendix F, section F.2.

Recommended Plan

To address delivery point performance, it is recommended that Hydro One Transmission undertake a staged approach. Stage 1 will entail a detailed field screening of the line for approximately \$154 thousand in 2017. Based on findings from the field screening, work to reduce the frequency of interruptions due to adverse weather should be implemented in 2018 and 2019. Cost for improvements is unknown at this time as it is dependent on actual findings. Performance will then be monitored for 2-3 years to verify improvement. Stage 2 will be based on the monitored performance and may entail strategically installing 115 kV in-line remotely-operated switches on circuit L7S to reduce the duration of interruptions. Switches are currently estimated to cost between \$1M to \$4M depending on the number of switches and their location. Funding of the staged plan to be as per the OEB-approved Hydro One Customer Delivery Point Performance Standard [EB-2002-0424, updated February 7, 2008]. Capital contribution from customers is not anticipated at this time. If, however, capital contribution is required from customers such financial obligation will be determined using methodology set out in the Transmission System Code.

7.3.3 Customers Supplied from Circuit D10H

The performance of delivery points supplied solely from circuit D10H, specifically Palmerston TS and Elmira TS were reviewed. The review is summarized in Appendix F, section F.3.

Current Status

Consultations with customers supplied from D10H are expected to be undertaken in 2017. Additional assessment and/or infrastructure to adhere to the OEB-approved funding rules for customer delivery point reliability improvements. Improvements may entail installing 115 kV in-line remotely operated switches for approximately \$1.5M. Funding of the staged plan to be as per the OEB-approved Hydro One Customer Delivery Point Performance Standard [EB-2002-0424, updated February 7, 2008]. Capital contribution might be required from customers and such financial obligation will be determined using methodology set out in the Transmission System Code.

7.4 Step-Down Transformation Capacity

7.4.1 Hydro One Distribution

The RIP load forecast in conjunction with more recent requests for step-down transformation capacity by Hydro One Distribution at Douglas Point TS indicates that additional step-down transformation capacity is needed.

Current Status

Hydro One Distribution is currently working with its customer to determine their connection capacity requirements, size and timeline. Once the customer's requirements are firm, one of the three "need" scenarios outlined in section 6.4 of this report will be undertaken.

7.5 Transmission Sustainment Plans

As part of Hydro One's transmitter requirements, Hydro One continues to ensure a reliable transmission system by carrying out maintenance programs as well as periodic replacement of equipment based on their condition. Table 7.1 lists Hydro One's major transmission sustainment *projects* in the Region that are currently planned or underway. There is currently no major line sustainment *projects* planned within the next 5 years. Maintenance *programs* such as insulator, shield wire, structure replacements will continue to be carried out in the Region as required based on equipment/asset condition assessments.

Table 7-1: Hydro One Transmission Major Sustainment Initiatives²

Station	General Description of Work	Planning In Service Date
Bruce A TS	<ul style="list-style-type: none"> Replacement of 230 kV circuit breakers Upgrading of the station strain buses Replacement of Protections and Control relay building 	2019
	<ul style="list-style-type: none"> Replacement of 500 kV circuit breakers and switches Replacement of 2 autotransformers 500/230 kV Upgrading of Protection and Control equipment 	2025
Bruce B SS	<ul style="list-style-type: none"> Replacement of 500 kV circuit breakers and switches 	2021

² Scope and dates as of July 2017 and are subject to change

Centralia TS	<ul style="list-style-type: none"> • Replace existing 3 transformers with a typical 25/42 MVA 2 transformer arrangement • Replacement of 27.6 kV switchyard • Installation of new PCT Facilities 	2019
Detweiler TS	<ul style="list-style-type: none"> • Replacement of AC and DC station service 	2018
	<ul style="list-style-type: none"> • Replacement of T2 and T4 autotransformers and upgrade to spill containment • Replacement Protection and Control equipment 	2021
Hanover TS	<ul style="list-style-type: none"> • Replacement of T1/T2 transformers and associated switches • Replacement of low voltage circuit breakers and switches • Replacement of Protection and Control systems and CVT's <p><i>Additional scope of work currently under development</i></p>	2023
Palmerston TS	<ul style="list-style-type: none"> • Replace existing 3 transformers with a typical 50/83 MVA 2 transformer arrangement. • Replacement of low voltage switches • Replacement of Protection and Control systems with new PCT facilities • Upgrade to AC & DC station services 	2019
Seaforth TS	<ul style="list-style-type: none"> • Replacement of 2 autotransformers 230/115 kV • Replacement of 2 step-down transformers 115/27.6 kV • Replacement of 230kV switches • Upgrade Protection and Control systems • Updated AC & DC station service 	2023
Wingham TS	<ul style="list-style-type: none"> • Complete station refurbishment <p><i>Additional scope of work currently under development</i></p>	2022

Based on the needs identified in the region thus far and the transmission sustainment plans listed in Table 7-1, consolidation of sustainment and development needs is not necessary at this time.

8. CONCLUSION

THIS REGIONAL INFRASTRUCTURE PLAN REPORT CONCLUDES THE REGIONAL PLANNING PROCESS FOR THE GREATER BRUCE-HURON REGION.

Five near and mid-term needs were identified for the Greater Bruce-Huron Region. They are:

- I. Transmission Circuit Capacity on L7S
- II. Low power factor at Wingham TS
- III. Low power factor at Bruce HWB TS
- IV. Customer delivery point performance review on the 115 kV system
- V. Step-down transformation capacity at Douglas Point TS

This RIP report addresses all five of these needs and has concluded that no regional plans for needs I, II and III are required at this time. Next Steps, Lead Responsibility, and Timeframes for implementing the regional plans needs IV and V are summarized in the Table 8-1 below.

Table 8-1: Regional Plans – Next Steps, Lead Responsibility and Plan In-Service Dates

No.	Project	Next Steps	Lead Responsibility	In-Service Date	Cost	Needs Mitigated
1	Improve 3L7S Delivery Point Performance	2 Stage Plan	Hydro One Transmission	2017-2023	\$154k - TBD	IV
2	Accommodation for Connection Capacity Requests near Kincardine–Hydro One Network Inc. Distribution	Await Customer Direction	Hydro One Distribution	TBD	TBD	V

In accordance with the Regional Planning process, the Regional Plan should be reviewed and/or updated at least every five years. The region will continue to be monitored and should there be a need that emerges due to a change in load forecast or any other reason, the next regional planning cycle will be started earlier to address the need.

9. REFERENCES

- [1] Hydro One, “Needs Assessment Report, Greater Bruce-Huron Region”, 6 May 2016.
<http://www.hydroone.com/RegionalPlanning/GreaterBruce-Huron/Documents/Needs%20Assessment%20Report%20-%20GreaterBruce-Huron%20Region.pdf>
- [2] Hydro One, “Local Planning Report – Low Power Factor at Wingham TS Assessment”, 18 October 2016.
<http://www.hydroone.com/RegionalPlanning/GreaterBruce-Huron/Documents/Local%20Planning%20Report%20-%20Wingham%20TS%20Power%20Factor%20Assessment.pdf>
- [3] Hydro One, “Local Planning Report – L7S Thermal Overload”, 14 November 2016.
<http://www.hydroone.com/RegionalPlanning/GreaterBruce-Huron/Documents/Local%20Planning%20Report%20-%20L7S%20Thermal%20Overload.pdf>
- [4] Hydro One, “Local Planning Report – Low TS Power Factor at Bruce heavy Water B TS Assessment”, 12 May 2017.
<http://www.hydroone.com/RegionalPlanning/GreaterBruce-Huron/Documents/Bruce%20HWB%20TS%20Power%20Factor%20Assessment%20-%20FINAL.PDF>

APPENDIX A: STEP-DOWN TRANSFORMER STATIONS IN THE GREATER BRUCE-HURON REGION

Station	Voltage (kV)	Supply Circuits
Bruce HWP B TS	230 kV	B20P/B24P
Douglas Point TS	230 kV	B20P/B24P
Hanover TS	115 kV	B4V/B5V
Owen Sound TS	230 kV	B27S/B28S
Seaforth TS	115 kV	B22D/B23D
Stratford TS	230 kV	B22D/B23D
Wingham TS	230 kV	B22D/B23D
Festival MTS #1	230 kV	B22D/B23D
Palmerston TS	115 kV	D10H
Goderich TS	115 kV	61M18
Constance DS	115 kV	61M18
St. Marys TS	115 kV	L7S
Customer CTS #1	115 kV	L7S
Centralia TS	115 kV	L7S
Grand Bend East DS	115 kV	L7S
Customer CTS #2	115 kV	L7S
Customer CTS #3	115 kV	L7S
Customer CTS #4	115 kV	L7S

APPENDIX B: REGIONAL TRANSMISSION CIRCUITS IN THE GREATER BRUCE-HURON REGION

Location	Circuit Designation	Voltage (kV)
Bruce A TS - Orangeville TS	B4V/B5V	230 kV
Bruce A TS - Detweiler TS	B22D/ B23D	230 kV
Bruce A TS - Owen Sound TS	B27S/B28S	230 kV
Bruce A TS - Douglas Point TS	B20P/B24P	230 kV
Hanover TS – Palmerston TS	D10H-North	115 kV
Seaforth TS - Goderich TS	61M18	115 kV
Seaforth TS - St. Marys TS	L7S	115 kV
Owen Sound TS – Hanover TS	S1H	115 kV

APPENDIX C: DISTRIBUTORS IN THE GREATER BRUCE-HURON REGION

Distributor Name	Station Name	Connection Type
Hydro One Networks Inc.	Constance	Tx
	Centralia TS	Dx
	Grand Bend East DS	Tx
	Douglas Point TS	Dx
	Goderich TS	Dx
	Hanover TS	Dx
	Owen Sound TS	Dx
	Palmerston TS	Dx
	Seaforth TS	Dx
	St. Marys TS	Dx
	Stratford TS	Dx
	Wingham TS	Dx
Erie Thames Power Lines Corporation	Constance DS	Dx
Festival Hydro Inc.	Grand Bend East DS	Dx
	Seaforth TS	Dx
	Stratford TS	Dx
	Festival MTS #1	Tx
Lake Huron Primary Water Supply System	Lake Huron WTP CTS	Tx
Lake Huron Primary Water Supply System	McGillivray R&BP CTS	Tx
West Coast Huron Energy Inc.	Goderich TS	Tx
Enbridge Pipeline Inc.	Enbridge Bryanston CTS	Tx
St. Marys Cement Inc.	St. Marys Cement CTS	Tx

APPENDIX D: REGIONAL LOAD FORECAST (2016-2025)

Table D-1: Gross – Winter Regional-Coincident Peak Load Forecast

Station	Forecast (MW)									
	2015/16	2016/17	2017/18	2018/19	2019/20	2020/21	2021/22	2022/23	2023/24	2024/25
Centralia TS	32.87	33.40	33.77	34.25	34.87	35.48	35.93	36.36	36.77	37.19
Constance DS	17.68	17.76	17.79	17.87	18.01	18.16	18.26	18.35	18.46	18.57
Douglas Point TS*	73.44	74.42	83.75	92.21	93.41	94.66	95.80	96.95	98.14	99.39
Customer CTS #1	0.90	0.90	0.90	0.90	0.90	0.90	0.90	0.90	0.90	0.90
Festival MTS #1	19.41	19.55	19.70	19.85	20.00	20.15	20.30	20.45	20.60	20.76
Goderich TS	36.35	36.50	36.59	36.73	36.92	37.11	37.25	37.37	37.49	37.61
Grand Bend East DS	14.22	14.36	14.43	14.55	14.72	14.89	15.00	15.09	15.19	15.28
Hanover TS	102.37	103.16	103.93	104.95	105.99	107.05	107.73	108.39	109.06	109.72
Customer CTS #2	4.30	4.30	4.30	4.30	4.30	4.30	4.30	4.30	4.30	4.30
Customer CTS #3	2.00	2.00	2.00	2.00	2.00	2.00	2.00	2.00	2.00	2.00
Owen Sound TS	135.53	137.73	139.21	141.20	143.81	146.38	148.20	149.90	151.56	153.19
Palmerston TS	61.92	62.92	63.88	65.12	66.22	67.44	68.42	69.41	70.41	71.40
Seaforth TS*	33.44	33.65	37.25	33.62	33.87	34.12	34.28	34.44	34.59	34.74
Customer CTS #4	9.49	10.07	10.07	10.64	10.64	10.64	10.64	10.64	10.64	10.64
St. Marys TS	23.74	25.04	25.17	25.31	25.50	25.69	25.84	25.98	26.12	26.25
Stratford TS*	80.14	80.81	81.39	85.46	86.20	86.93	87.56	88.18	88.79	89.41
Wingham TS	48.99	49.80	50.44	51.23	52.24	53.24	54.07	54.89	55.74	56.62
Bruce HWB TS	10.96	11.10	11.10	11.10	11.10	11.10	11.10	11.10	11.10	11.10

*Updated March 2017 for RIP

Table D-2: Gross – Summer Regional-Coincident Peak Load Forecast

Station	Forecast (MW)									
	2016	2017	2018	2019	2020	2021	2022	2023	2024	2025
Centralia TS	32.42	32.73	33.15	33.78	34.40	34.83	35.24	35.65	36.05	36.45
Constance DS	15.56	15.57	15.63	15.76	15.90	15.98	16.07	16.16	16.26	16.36
Douglas Point TS*	47.40	47.40	63.29	63.76	64.26	64.64	65.03	65.41	65.78	66.18
Customer CTS #1	1.30	1.30	1.30	1.30	1.30	1.30	1.30	1.30	1.30	1.30
Festival MTS #1	25.03	25.22	25.41	25.60	25.79	25.98	26.18	26.37	26.57	26.77
Goderich TS	39.08	39.15	39.27	39.48	39.68	39.81	39.93	40.06	40.18	40.31
Grand Bend East DS	16.44	16.50	16.62	16.84	17.05	17.17	17.29	17.39	17.50	17.61
Hanover TS	76.71	76.94	77.62	78.60	79.25	79.71	80.12	80.53	80.93	81.32
Customer CTS #2	5.58	5.58	5.58	5.58	5.58	5.58	5.58	5.58	5.58	5.58
Customer CTS #3	4.20	4.20	4.20	4.20	4.20	4.20	4.20	4.20	4.20	4.20
Owen Sound TS	97.58	98.48	99.75	101.70	103.59	104.89	106.11	107.31	108.48	109.63
Palmerston TS	53.07	53.79	54.90	56.36	57.68	58.81	59.97	61.19	62.43	63.75
Seaforth TS*	30.68	34.34	30.56	30.78	30.99	31.14	31.27	30.78	31.54	31.67
Customer CTS #4	14.62	15.54	15.54	16.47	16.47	16.47	16.47	16.47	16.47	16.47
St. Marys TS	25.31	25.42	25.57	25.75	25.94	26.09	26.24	26.38	26.52	26.66
Stratford TS*	78.09	78.59	82.38	83.14	83.91	84.52	85.11	85.70	86.29	86.88
Wingham TS	37.99	38.11	38.36	38.87	39.37	39.67	39.97	40.26	40.54	40.83
Bruce HWB TS	5.14	5.24	5.34	5.44	5.54	5.64	5.74	5.84	5.93	6.03

*Updated March 2017 for RIP

Table D-3: Gross – Winter Non-Coincident Peak Load Forecast

Station	Forecast (MW)									
	2015/16	2016/17	2017/18	2018/19	2019/20	2020/21	2021/22	2022/23	2023/24	2024/25
Centralia TS	34.15	34.70	35.08	35.59	36.23	36.87	37.33	37.77	38.21	38.63
Constance DS	19.42	19.51	19.54	19.63	19.79	19.95	20.06	20.17	20.28	20.40
Douglas Point TS*	73.44	74.42	83.75	92.21	93.41	94.66	95.80	96.95	98.14	99.39
Customer CTS #1	3.79	3.79	3.79	3.79	3.79	3.79	3.79	3.79	3.79	3.79
Festival MTS #1	25.47	25.66	25.85	26.05	26.24	26.44	26.64	26.84	27.04	27.24
Goderich TS	41.61	41.78	41.88	42.04	42.26	42.48	42.63	42.77	42.91	43.05
Grand Bend East DS	14.75	14.89	14.97	15.09	15.27	15.45	15.56	15.66	15.75	15.85
Hanover TS	96.65**	97.40	98.12	99.09	100.07	101.06	101.71	102.33	102.97	103.58
Customer CTS #2	5.90	5.90	5.90	5.90	5.90	5.90	5.90	5.90	5.90	5.90
Customer CTS #3	4.63	4.63	4.63	4.63	4.63	4.63	4.63	4.63	4.63	4.63
Owen Sound TS	135.53	137.73	139.21	141.20	143.81	146.38	148.20	149.90	151.56	153.19
Palmerston TS	68.03**	69.12	70.18	71.54	72.76	74.10	75.17	76.26	77.36	78.45
Seaforth TS*	34.75	34.96	38.70	34.92	35.19	35.44	35.62	35.78	35.93	36.09
Customer CTS #4	17.06	18.10	18.10	19.14	19.14	19.14	19.14	19.14	19.14	19.14
St. Marys TS	25.13	26.50	26.64	26.79	26.99	27.19	27.35	27.50	27.64	27.78
Stratford TS*	84.52	85.23	85.84	90.13	90.91	91.69	92.36	93.00	93.65	94.30
Wingham TS	57.98	58.94	59.70	60.63	61.82	63.01	63.98	64.96	65.96	67.00
Bruce HWB TS	11.07	11.20	11.20	11.20	11.20	11.20	11.20	11.20	11.20	11.20

*Updated March 2017 for RIP

**Load Transfer from Hanover TS to Palmerston TS

Table D-4: Gross – Summer Non-Coincident Peak Load Forecast

Station	Forecast (MW)									
	2016	2017	2018	2019	2020	2021	2022	2023	2024	2025
Centralia TS	34.23	34.56	35.01	35.67	36.32	36.78	37.22	37.64	38.07	38.49
Constance DS	17.78	17.79	17.86	18.01	18.17	18.27	18.36	18.47	18.58	18.70
Douglas Point TS*	48.06	48.06	64.17	64.65	65.15	65.54	65.93	66.32	66.69	67.10
Customer CTS #1	3.00	3.00	3.00	3.00	3.00	3.00	3.00	3.00	3.00	3.00
Festival MTS #1	28.11	28.32	28.53	28.74	28.96	29.18	29.39	29.61	29.84	30.06
Goderich TS	40.71	40.78	40.91	41.12	41.33	41.46	41.59	41.72	41.85	41.98
Grand Bend East DS	18.88	18.95	19.09	19.34	19.58	19.72	19.85	19.98	20.10	20.22
Hanover TS	75.61**	75.84	76.50	77.47	78.12	78.57	78.97	79.37	79.77	80.15
Customer CTS #2	5.79	5.79	5.79	5.79	5.79	5.79	5.79	5.79	5.79	5.79
Customer CTS #3	4.53	4.53	4.53	4.53	4.53	4.53	4.53	4.53	4.53	4.53
Owen Sound TS	101.31	102.25	103.57	105.59	107.55	108.90	110.17	111.41	112.63	113.82
Palmerston TS	54.71**	55.45	56.60	58.10	59.46	60.63	61.82	63.07	64.36	65.72
Seaforth TS*	31.00	34.70	30.87	31.10	31.31	31.46	31.59	31.10	31.86	31.99
Customer CTS #4	16.22	17.24	17.24	18.27	18.27	18.27	18.27	18.27	18.27	18.27
St. Marys TS	26.05	26.17	26.31	26.51	26.70	26.86	27.01	27.16	27.30	27.44
Stratford TS*	88.42	88.99	93.28	94.15	95.01	95.70	96.38	97.05	97.71	98.37
Wingham TS	54.05	54.21	54.58	55.29	56.00	56.43	56.86	57.27	57.67	58.08
Bruce HWB TS	6.54	6.66	6.79	6.91	7.04	7.16	7.29	7.42	7.54	7.67

*Updated March 2017 for RIP

**Load Transfer from Hanover TS to Palmerston TS

Table D-5: Net – Winter Regional-Coincident Peak Load Forecast

Station	Forecast (MW)									
	2015/16	2016/17	2017/18	2018/19	2019/20	2020/21	2021/22	2022/23	2023/24	2024/25
Centralia TS	32.65	32.92	32.96	33.16	33.52	33.90	34.16	34.45	34.69	34.94
Constance DS	17.57	17.55	17.41	17.35	17.36	17.40	17.41	17.44	17.46	17.50
Douglas Point TS*	72.99	73.55	81.97	89.53	90.03	90.70	91.34	92.11	92.84	93.64
Customer CTS #1	0.90	0.90	0.90	0.90	0.90	0.90	0.90	0.90	0.90	0.90
Festival MTS #1	19.29	19.33	19.29	19.27	19.28	19.31	19.36	19.43	19.49	19.56
Goderich TS	36.12	36.07	35.81	35.65	35.58	35.55	35.50	35.49	35.45	35.43
Grand Bend East DS	14.13	14.19	14.13	14.13	14.19	14.27	14.30	14.34	14.37	14.39
Hanover TS	101.72	101.94	101.69	101.76	102.01	102.42	102.56	102.84	103.02	103.23
Customer CTS #2	4.30	4.30	4.30	4.30	4.30	4.30	4.30	4.30	4.30	4.30
Customer CTS #3	2.00	2.00	2.00	2.00	2.00	2.00	2.00	2.00	2.00	2.00
Owen Sound TS	134.70	136.07	136.18	137.02	138.53	140.18	141.21	142.35	143.29	144.25
Palmerston TS	61.53	62.17	62.50	63.20	63.80	64.60	65.20	65.92	66.58	67.25
Seaforth TS*	33.24	33.26	36.45	32.63	32.64	32.68	32.68	32.72	32.71	32.72
Customer CTS #4	9.49	10.07	10.07	10.64	10.64	10.64	10.64	10.64	10.64	10.65
St. Marys TS	23.59	24.75	24.63	24.57	24.58	24.61	24.63	24.68	24.70	24.73
Stratford TS*	79.65	79.87	79.65	82.97	83.08	83.29	83.48	83.78	83.99	84.23
Wingham TS	48.70	49.23	49.38	49.75	50.36	51.02	51.55	52.16	52.73	53.35
Bruce HWB TS	10.96	11.10	11.10	11.10	11.10	11.10	11.10	11.10	11.10	11.10

*Updated March 2017 for RIP

Table D-6: Net – Summer Regional-Coincident Peak Load Forecast

Station	Forecast (MW)									
	2016	2017	2018	2019	2020	2021	2022	2023	2024	2025
Centralia TS	32.04	31.57	31.62	31.89	32.20	32.42	32.61	32.85	33.05	33.25
Constance DS	15.45	15.35	15.23	15.20	15.20	15.19	15.18	15.20	15.22	15.24
Douglas Point TS*	47.00	46.67	61.64	61.45	61.39	61.39	61.38	61.49	61.50	61.58
Customer CTS #1	1.30	1.30	1.30	1.30	1.30	1.30	1.30	1.30	1.30	1.30
Festival MTS #1	24.85	24.86	24.77	24.69	24.66	24.70	24.74	24.82	24.87	24.93
Goderich TS	38.70	38.50	38.18	37.98	37.84	37.74	37.63	37.59	37.50	37.43
Grand Bend East DS	16.32	16.27	16.20	16.24	16.31	16.33	16.33	16.37	16.38	16.40
Hanover TS	75.82	75.51	75.32	75.37	75.34	75.33	75.25	75.32	75.30	75.29
Customer CTS #2	5.58	5.58	5.58	5.58	5.58	5.58	5.58	5.58	5.58	5.58
Customer CTS #3	4.20	4.20	4.20	4.20	4.20	4.20	4.20	4.20	4.20	4.20
Owen Sound TS	96.71	96.49	96.54	97.40	98.36	99.01	99.56	100.27	100.83	101.40
Palmerston TS	52.48	52.81	53.30	54.15	54.94	55.69	56.45	57.35	58.21	59.16
Seaforth TS*	30.39	33.79	29.72	29.62	29.57	29.53	29.48	28.89	29.45	29.42
Customer CTS #4	14.62	15.54	15.54	16.47	16.47	16.47	16.47	16.47	16.47	16.47
St. Marys TS	25.07	25.01	24.87	24.79	24.76	24.75	24.74	24.77	24.77	24.78
Stratford TS*	77.42	77.37	80.20	80.09	80.13	80.23	80.31	80.53	80.65	80.80
Wingham TS	37.72	37.57	37.40	37.49	37.65	37.71	37.76	37.88	37.94	38.03
Bruce HWB TS	5.06	5.12	5.12	5.12	5.12	5.12	5.12	5.12	5.12	5.12

*Updated March 2017 for RIP

Table D-7: Net – Winter Non-Coincident Peak Load Forecast

Station	Forecast (MW)									
	2015/16	2016/17	2017/18	2018/19	2019/20	2020/21	2021/22	2022/23	2023/24	2024/25
Centralia TS	33.93	34.20	34.24	34.46	34.82	35.23	35.50	35.79	36.05	36.31
Constance DS	18.62	18.61	18.45	18.39	18.40	18.44	18.45	18.48	18.51	18.55
Douglas Point TS*	72.99	73.55	81.97	89.53	90.03	90.70	91.34	92.11	92.84	93.64
Customer CTS #1	3.79	3.79	3.79	3.79	3.79	3.79	3.79	3.79	3.79	3.79
Festival MTS #1	23.83	23.87	23.82	23.80	23.81	23.84	23.90	24.00	24.07	24.16
Goderich TS	40.85	40.79	40.49	40.32	40.23	40.20	40.15	40.14	40.09	40.06
Grand Bend East DS	14.66	14.72	14.65	14.65	14.72	14.81	14.84	14.88	14.90	14.93
Hanover TS	102.77*	102.99	102.75	102.81	103.07	103.48	103.63	103.90	104.09	104.30
Customer CTS #2	5.90	5.90	5.90	5.90	5.90	5.90	5.90	5.90	5.90	5.90
Customer CTS #3	4.63	4.63	4.63	4.63	4.63	4.63	4.63	4.63	4.63	4.63
Owen Sound TS	134.70	136.07	136.18	137.02	138.53	140.18	141.21	142.35	143.29	144.25
Palmerston TS	62.06*	62.70	63.04	63.75	64.36	65.15	65.77	66.49	67.16	67.83
Seaforth TS*	33.66	33.68	36.92	33.05	33.05	33.10	33.09	33.13	33.13	33.14
Customer CTS #4	17.06	18.10	18.10	19.14	19.14	19.14	19.14	19.14	19.14	19.14
St. Marys TS	24.97	26.19	26.07	26.01	26.01	26.04	26.07	26.12	26.14	26.17
Stratford TS*	83.99	84.23	84.00	87.49	87.61	87.83	88.03	88.34	88.57	88.83
Wingham TS	57.64	58.26	58.44	58.87	59.59	60.38	61.01	61.73	62.41	63.14
Bruce HWB TS	11.07	11.20	11.20	11.20	11.20	11.20	11.20	11.20	11.20	11.20

*Updated March 2017 for RIP

Table D-8: Net – Summer Non-Coincident Peak Load Forecast

Station	Forecast (MW)									
	2016	2017	2018	2019	2020	2021	2022	2023	2024	2025
Centralia TS	33.84	33.38	33.43	33.72	34.04	34.27	34.47	34.72	34.93	35.15
Constance DS	17.66	17.54	17.41	17.37	17.38	17.36	17.35	17.38	17.39	17.42
Douglas Point TS	47.66	47.32	62.49	62.30	62.24	62.24	62.23	62.35	62.36	62.44
Customer CTS #1	3.00	3.00	3.00	3.00	3.00	3.00	3.00	3.00	3.00	3.00
Festival MTS #1	27.91	27.92	27.81	27.73	27.69	27.74	27.77	27.87	27.93	28.00
Goderich TS	39.02	38.81	38.49	38.29	38.15	38.05	37.93	37.89	37.81	37.74
Grand Bend East DS	18.75	18.68	18.61	18.65	18.73	18.75	18.76	18.80	18.81	18.83
Hanover TS	75.82	75.51	75.32	75.37	75.34	75.33	75.25	75.32	75.30	75.29
Customer CTS #2	5.79	5.79	5.79	5.79	5.79	5.79	5.79	5.79	5.79	5.79
Customer CTS #3	4.53	4.53	4.53	4.53	4.53	4.53	4.53	4.53	4.53	4.53
Owen Sound TS	100.41	100.21	100.26	101.16	102.15	102.82	103.40	104.13	104.72	105.31
Palmerston TS	52.80	53.13	53.63	54.48	55.27	56.03	56.79	57.70	58.57	59.52
Seaforth TS	30.39	33.79	29.72	29.62	29.57	29.53	29.48	28.89	29.45	29.42
Customer CTS #4	16.22	17.24	17.24	18.27	18.27	18.27	18.27	18.27	18.27	18.27
St. Marys TS	25.81	25.74	25.60	25.52	25.49	25.48	25.47	25.50	25.50	25.50
Stratford TS	86.73	86.68	89.84	89.72	89.77	89.88	89.97	90.21	90.35	90.52
Wingham TS	50.79	50.58	50.35	50.48	50.69	50.77	50.84	51.00	51.08	51.20
Bruce HWB TS	9.83	9.95	9.95	9.95	9.95	9.95	9.95	9.95	9.95	9.95

*Updated March 2017 for RIP

APPENDIX E: RIP TRANSMISSION ADEQUACY ASSESSMENT

This table assesses the impact of the updated March 2017 RIP load forecast based on the original findings of the May 2016 Needs Assessment.

Change in Load Forecast	Seaforth TS			Stratford TS			Douglas Point TS		
		Coincident	Non-Coincident		Coincident	Non-Coincident		Coincident	Non-Coincident
		MW	MW		MW	MW		MW	MW
Red font indicates an increase in forecasted load from the Needs Assessment.	summer: 2025 Gross	31.67	31.67	summer: 2025 Gross	86.88	98.37	summer: new 2025 Gross	66.18	67.1
	summer: 2025 Net	29.42	29.42	summer: 2025 Net	80.8	90.52	summer: new 2025 Net	61.58	62.44
	summer 10 Day LTR	39.3 MW		summer 10 Day LTR	104.4 MW		summer 10 Day LTR	87.5 MVA	
Green font indicates a reduction in forecasted load from the Needs Assessment.	winter: new 2025 Gross	34.74	36.09	winter: new 2025 Gross	89.41	94.3	winter: new 2025 Gross	99.39	99.39
	winter: new 2025 Net	32.72	33.14	winter: new 2025 Net	84.23	88.83	winter: new 2025 Net	93.64	93.64
	winter 10 Day LTR	49.9 MW		winter 10 Day LTR	115.7 MW		winter 10 Day LTR	98.8 MW	
Historical Power Factor	N/A			N/A			N/A		
Load Security	no negative impact			no negative impact			no negative impact		
Load Restoration	no negative impact			no negative impact			no negative impact		
Voltage Performance	no negative impact			no negative impact			no negative impact		
CDPP	N/A			N/A			N/A		
230/115 kV Autos	no negative impact			no negative impact			no negative impact		
230 kV Lines	no negative impact			no negative impact			no negative impact		
115 kV Lines	no negative impact			no negative impact			no negative impact		
Step down Transformation Capacity	no negative impact			Study shows that there is a slight impact but loading remains within LTR and at least one LV cap must be in-service during summer loading by the end of the study period. This is similar to the Needs Assessment results.			Study shows that the gross winter forecast loading is at the LTR in winter 2023/2024. All summer forecasts show loading is within LTR for the study period.		
Bulk System Performance	no negative impact			no negative impact			no negative impact		

APPENDIX F: CUSTOMER DELIVERY POINT PERFORMANCE REVIEW

Based on the recommendations from the May 2016 Needs Assessment, 15 customer delivery points were reviewed in detail to assess their reliability performance. Reliability performance of a delivery point is a measure of the frequency of interruption and duration of interruption. The yearly frequency and yearly total duration of interruptions are compared against Hydro One performance standards filed with the OEB, [EB-2002-0424, updated February 7, 2008].

All 15 delivery points are supplied solely from single circuit 115 kV transmission lines and are grouped as follows:

Table F-1 - Customer Delivery Points

Single circuit 115 kV Transmission Line	Station	# of Customer Delivery Points
61M18	Goderich TS	2
	Constance DS	1
L7S	Centralia TS	2
	Grand Bend East DS	1
	St. Mary TS	1
	Industrial Customer # 1	1
	Industrial Customer # 2	1
	Industrial Customer # 3	1
	Industrial Customer # 4	1
D10H -North	Palmerston TS	2
D10H - South	Elmira TS	2

The reliability performance of the delivery points were studied in groups based on their connection point to the transmission system, specifically their 115 kV transmission line supply as shown in Table F-1.

The review of each delivery point included a 10 year review of interruptions between years 2006 and 2015. The interruptions were compared against each delivery points “Group” metrics as defined in the OEB filing as well as each delivery points “Individual Historical Performance” as defined in the OEB filing. Where the yearly performance did not meet either the Group or Individual standards for either frequency or duration of interruptions, Hydro One Transmission classified the delivery point as an “Outlier”. Based on a delivery point’s Outlier status, their reliability performance is reviewed. The summary of review is given below.

F.1 Delivery Points Supplied by Transmission Line 61M18

In the past, 2006-2010, Goderich TS was classified as a Group Outlier for both frequency and duration of interruption. Recently it is classified as a Group Outlier for duration only. These classifications are mainly due to past equipment failures at Seaforth TS and recently as a consequence of line 61M18 tied to line L7S while L7S experienced interruptions.

Constance DS is not classified as a Group Outlier; however it is occasionally classified as an Individual Outlier for duration of interruption. Although Constance DS is subject to the same line 61M18 interruptions as Goderich TS, it is typically not classified as a Group Outlier because it has less stringent performance metrics due to the smaller amount of load (MW) supplied from it.

The review showed that the root cause of interruptions is due to the performance of the transmission line 61M18 during adverse weather. When 61M18 is interrupted, all load connected to Constance DS and Goderich TS is left unsupplied. As line 61M18 is radial, there are not many options to resupply the load prior to repairing the line. Often building a temporary bypass can take longer than fixing the damaged equipment and the ability to transfer the load to other stations is limited due to the sparse topology of customer distribution systems. Overall, customers supplied from Constance DS and Goderich TS have similar delivery point performance compared to other customers supplied by a single radial circuit and poor delivery point performance compared to other customers supplied by dual circuits. Additionally, a technical review concluded that the transmission line is performing as originally designed with respect to line design security parameters which correspond to a line's susceptibility to faults caused by external forces such as lightning and storms.

As upgrading the transmission supply to these stations is not economical for neither the customers nor Hydro One Transmission based on the OEB-approved funding rules for customer delivery point reliability improvement, it is recommended for Hydro One Transmission to continue to rely on its Line and Station maintenance and capital sustainment projects to improve the overall reliability performance to delivery points. Based on customer consultations, Goderich Hydro - West Coast Huron Energy Inc., Erie Thames Power and Hydro One Distribution have agreed to this approach and will continue to monitor performance.

F.2 Delivery Points Supplied by Transmission Line L7S

Centralia TS is classified as a Group Outlier for both frequency and duration of interruption. Recently in 2013 and 2014 it has also been classified as an Individual Outlier for duration of interruption.

Grand Bend East DS is classified as a Group Outlier for both frequency (occasionally) and duration (consistently) of interruption, as well as an Individual Outlier for duration.

All four industrial customer delivery points are occasionally classified as a Group Outlier for frequency of interruption; while one of them often is classified as a Group Outlier for duration of interruption. Over the

past 3 years, the industrial customer delivery points have often been classified as Individual Outliers for duration.

The review showed that the root cause of interruptions is due to the performance of the transmission line L7S during adverse weather. When L7S is interrupted, all load connected to it is left unsupplied. As line L7S is radial, there are not many options to resupply the load prior to repairing the line. Often building a temporary bypass can take longer than fixing the damaged equipment and the ability to transfer the load to other stations is limited due to the sparse topology of customer distribution systems. Depending on prevailing system conditions, manual switching on the transmission system can be performed to resupply some L7S load from Detweiler TS via 115 kV circuit D8S. Overall, customers supplied from L7S have similar delivery point performance compared to other customers supplied by a single radial circuit and poor delivery point performance compared to other customers supplied by dual circuits. Additionally, a technical review concluded that the transmission line is performing as originally designed with respect to line design security parameters which correspond to a line's susceptibility to faults caused by external forces such as lightning and storms.

Due to the Individual Outlier classification of delivery points supplied from L7S it is recommended that a focused line assessment is undertaken. Although major upgrades to the transmission supply is not economical for neither the customers nor Hydro One Transmission based on the OEB-approved funding rules for customer delivery point reliability improvement, it remains the recommendation for Hydro One Transmission to improve the reliability of transmission line L7S. A two stage approach is prudent. Stage 1 will entail a detailed field screening of the line for approximately \$154 k in 2017. Based on findings from the field screening, work to reduce the frequency of interruptions due to adverse weather should be implemented in 2018 and 2019. Cost for improvements is unknown at this time as it is dependent on actual findings. Performance will then be monitored for 2-3 years to verify improvement. It is expected that reduction to the frequency of interruptions will reduce the total duration of interruptions. Stage 2 will be based on the monitored performance and may entail strategically installing 115 kV in-line remotely-operated switches to reduce the duration of interruptions. Switches are currently estimated to cost between \$1M to \$4M depending on the number of switches and their location.

Based on customer consultations, Festival Hydro, Hydro One Distribution and the industrial customers have agreed to this approach.

F.3 Delivery Points Supplied by Transmission Line D10H

115 kV circuit D10H between Detweiler TS and Hanover TS is operated normally-open at Palmerston TS whereby Palmerston TS is normally supplied from Hanover TS (D10H-North) while Elmira TS is normally supplied from Detweiler TS (D01H – South).

Over the past 3 years, Palmerston TS has been classified as a Group Outlier for both frequency and duration of interruption. It has not been classified as an Individual Outlier over the 10 year review period.

Over the past 3 years, Elmira TS has been classified as a Group Outlier for both frequency and duration of interruption. It has been classified as an Individual Outlier once in the 10 year review period; specifically in 2013 for frequency of interruption.

The review showed that the root cause of interruptions is due to the performance of the transmission lines D10H-North and D10H-South during adverse weather. When D10H-North is interrupted, all load connected to Palmerston TS is left unsupplied. When D10H-South is interrupted, all load connected to Elmira TS is left unsupplied. Since there are several 115 kV in-line switches along D10H and depending on prevailing system conditions, circuit D10H can be reconfigured to supply Palmerston TS and Elmira TS from either the Hanover TS or Detweiler TS ends. 115 kV in-line switches at Palmerston TS have the capability to be operated remotely. There are two other manual-operated switches surrounding the tap to Elmira TS.

Overall, customers supplied from Palmerston TS and Elmira TS have similar delivery point performance compared to other customers supplied by a single radial circuit and poor delivery point performance comparable to other customers supplied by dual circuits. Additionally, a technical review concluded that the transmission line is performing as originally designed with respect to line design security parameters which correspond to a line's susceptibility to faults caused by external forces such as lightning and storms.

Consultations with customers supplied from D10H are expected to be undertaken in 2017. Additional assessment and/or infrastructure to adhere to the OEB-approved funding rules for customer delivery point reliability improvements. Improvements may entail installing 115 kV in-line remotely operated switches for approximately \$1.5M.

APPENDIX G: LIST OF ACRONYMS

Acronym	Description
A	Ampere
BES	Bulk Electric System
BPS	Bulk Power System
CDM	Conservation and Demand Management
CIA	Customer Impact Assessment
CGS	Customer Generating Station
CSS	Customer Switching Station
CTS	Customer Transformer Station
DCF	Discounted Cash Flow
DESN	Dual Element Spot Network
DG	Distributed Generation
DSC	Distribution System Code
GATR	Guelph Area Transmission Reinforcement
GS	Generating Station
GTA	Greater Toronto Area
HV	High Voltage
IESO	Independent Electricity System Operator
IRRP	Integrated Regional Resource Plan
kV	Kilovolt
LDC	Local Distribution Company
LP	Local Plan
LTE	Long Term Emergency
LTR	Limited Time Rating
LV	Low Voltage
MTS	Municipal Transformer Station
MW	Megawatt
MVA	Mega Volt-Ampere
MVAR	Mega Volt-Ampere Reactive
NA	Needs Assessment
NERC	North American Electric Reliability Corporation
NGS	Nuclear Generating Station
NPCC	Northeast Power Coordinating Council Inc.
NUG	Non-Utility Generator
OEB	Ontario Energy Board
OPA	Ontario Power Authority
ORTAC	Ontario Resource and Transmission Assessment Criteria
PF	Power Factor
PPWG	Planning Process Working Group
RIP	Regional Infrastructure Plan
ROW	Right-of-Way
SA	Scoping Assessment
SIA	System Impact Assessment
SPS	Special Protection Scheme
SS	Switching Station
TS	Transformer Station
TSC	Transmission System Code
UFLS	Under Frequency Load Shedding
ULTC	Under Load Tap Changer
UVLS	Under Voltage Load Rejection Scheme